

# 99670

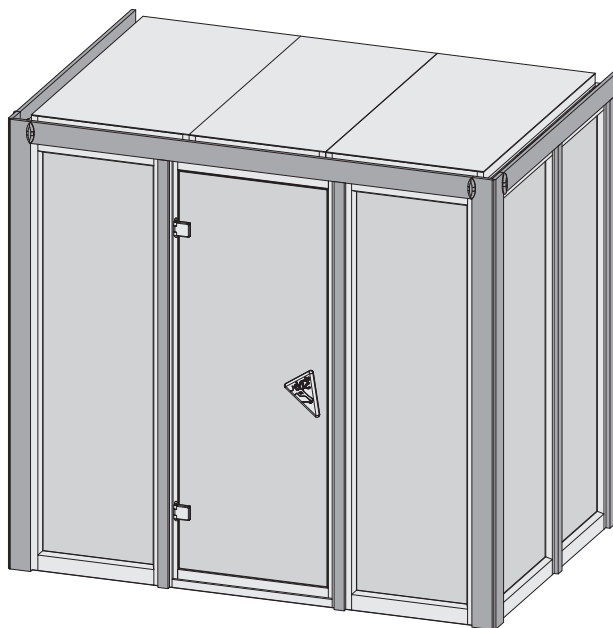

-  **Aufbauanleitung**
-  **Building Instructions**
-  **notice de montage**
-  **montagehandleiding**
-  **Montagevejledning**
-  **Instrucciones de construcción**
-  **Istruzioni per il montaggio**
-  **Montážní návod**
-  **Navodila za sestavljanje**







Bitte bewahren Sie die Anleitung und den Garantieschein zur Seriennummer auf.





Vernichten Sie diese erst nach Ablauf der Garantiezeit.





Eventuelle Beanstandungen können mithilfe der Stückliste einfacher zugeordnet werden.





#### Beigelegte Dokumente

- Informationsheft
- Garantieschein zur Seriennummer
- Typenschild inkl. Warnhinweise (Sauna)
- ggf. Zubehör-Anleitungen in externen Paketen





- \*  Nicht im Lieferumfang enthalten  
 Not included  
 Non comprises dans la livraison  
 Niet bijgeleverd

-  No forman parte del suministro  
 Non incluso  
 V ceně není zahrnuto  
 Ikke inkluderet  
 Ni včlučeno v obseg dobave

- 1  Länge muss ermittelt und zugesagt werden  
 Length must be determined and sawn  
 La longueur doit être déterminée et sciée  
 De lengte moet worden bepaald en worden gezaagd

-  La longitud debe ser determinada y aserrada  
 La lunghezza deve essere determinata e segata  
 Délka musí být určena a rozřezána  
 Længden skal bestemmes og saves  
 Določiti je treba dolžino in jo odrezati po velikosti.





- 2  Nicht gebraucht  
 Not needed  
 Pas nécessaire  
 Niet nodig

-  No es necesario  
 Non necessario  
 Není nutná  
 Ikke nødvendig  
 Ne uporabljaja se

- 3  Mit Zubehör  
 With accessories  
 Avec accessoires  
 Met toebehoren

-  Con accesorios  
 Con accessori  
 S příslušenstvím  
 Med tilbehør  
 Z dodatki

- 4  Fixiert vorübergehend  
 Fixed temporarily  
 Temporairement fixe  
 Tijdelijk vast

-  Temporalmente fijo  
 Temporaneamente fisso  
 Dočasně pevný  
 Midlertidigt rettet  
 Začasno popravi

- 5  Bestand vom Haus  
 Inventory of the house  
 Inventaire de la maison  
 Inventaris von het huis

-  Inventario de la casa  
 Inventario della casa  
 Inventář domu  
 Inventar af huset  
 Inventarizacija hiše

 Vergleichen Sie zuerst die Material-liste mit Ihrem Paketinhalt! Bitte haben Sie Verständnis, dass Beanstandungen nur im nicht aufgebauten Zustand bearbeitet werden können!

 First compare the list of materials with your package contents! Please understand that complaints can be processed in the non-built status only!

 Commencez par comparer la liste du matériel avec le contenu de votre paquet! Sachez que nous traitons uniquement les réclamations concernant le matériel à l'état non monté!

 Vergelijk eerst de lijst van materialen met de inhoud van uw pakket! Reclamaties kunnen alleen in behandeling worden genomen zolang de onderdelen nog niet zijn gemonteerd!

 Start med at kontrollere materialelisten med indholdet af den leverede pakke! Vi gør venligst opmærksom på at reklamationer kun kan behandles for materialer som ikke er blevet bearbejdet!

 En primer lugar, compare la lista de material con el contenido del paquete. Rogamos entienda que las reclamaciones sólo pueden ser tramitadas antes de montar el objeto!

 Confrontate questa distinta materiali prima con il contenuto del pacchetto! Vi preghiamo di comprendere che eventuali reclami possono essere accolti solo prima del montaggio!

 Nejprve překontrolujte obsah balení podle materiálového listu! Mějte pochopení pro to, že případnou reklamaci se můžeme zabývat pouze tehdy, když díly nebudou smontované! Za pomoci tohoto seznamu můžete jednotlivé díly přiřadit k montážnímu návodu.

 Najprej primerajte seznam materialov z vsebino vašega paketa! Upoštevajte, da lahko pritožbe obravnavamo le v nesešavljenem stanju!

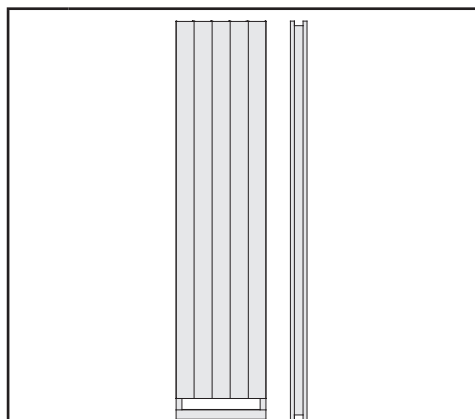
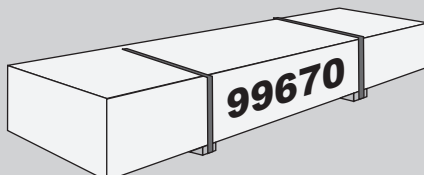

1 x **W1** | 1920 x 606 x 68 mm | ID 25550

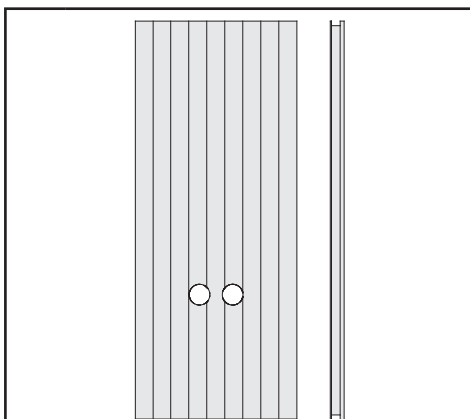

1 x **W2** | 1920 x 780 x 57 mm | ID 70556

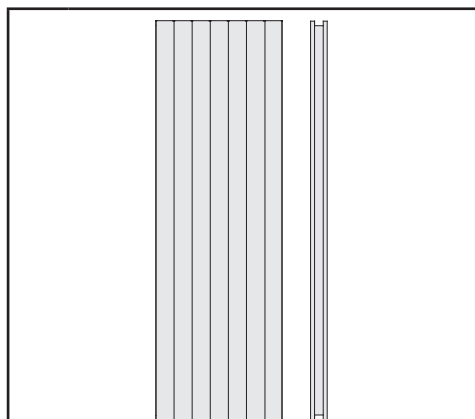

1 x **W3** | 1920 x 606 x 68 mm | ID 25548

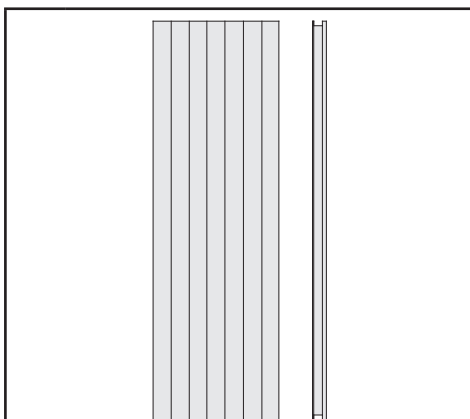

2 x **W4** | 1920 x 606 x 57 mm | ID 23624

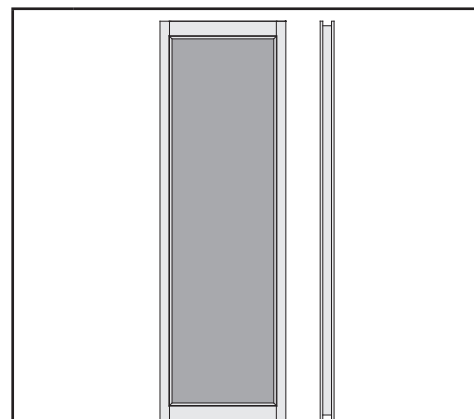

4 x **W5** | 1920 x 606 x 68 mm | ID 47717

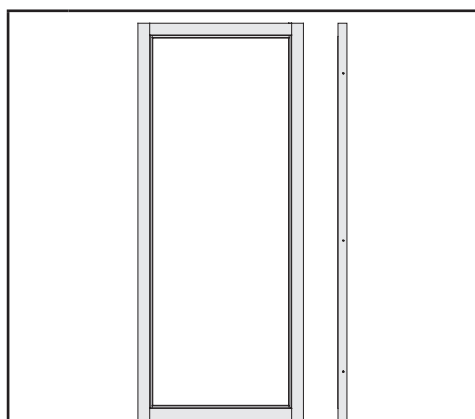

1 x **X1** | 1872 x 780 x 68 mm | ID 26499

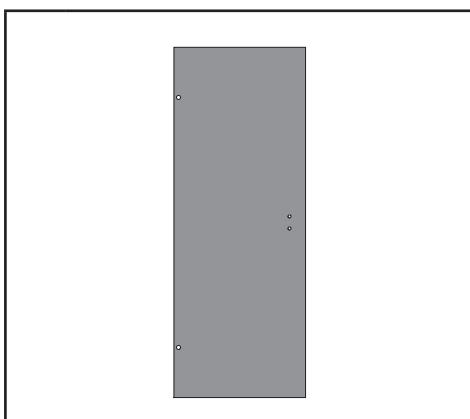

1 x **X2** | | ID 26494

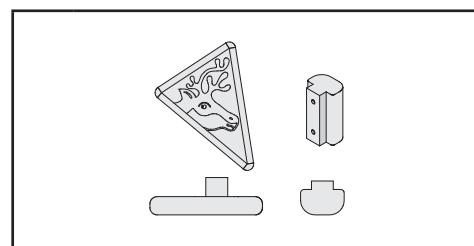

1 x **X3** | | ID 26114

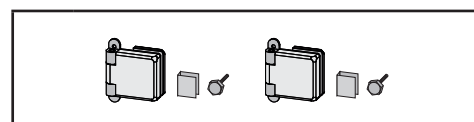

1 x **X4** | | ID 26496

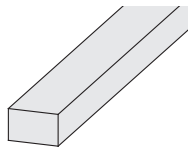

6 x <b>B1</b>	1920 x 19 x 3 mm	ID 20799
4 x <b>B2</b>	750 x 36 x 12 mm	ID 24239
4 x <b>B3</b>	1920 x 36 x 12 mm	ID 24846
1 x <b>B4</b>	1377 x 90 x 16 mm	ID 72991
1 x <b>B5</b>	1985 x 90 x 16 mm	ID 36745
6 x <b>B6</b>	1884 x 45 x 17 mm	ID 48037
9 x <b>B7</b>	460 x 95 x 18 mm	ID 25412
2 x <b>B8</b>	1278 x 95 x 18 mm	ID 26575
1 x <b>B9</b>	1958 x 95 x 18 mm	ID 72397
1 x <b>B10</b>	300 x 120 x 18 mm	ID 22467
2 x <b>B11</b>	770 x 42 x 28 mm	ID 45968
2 x <b>B12</b>	1080 x 42 x 28 mm	ID 45157
2 x <b>B13</b>	1209 x 42 x 28 mm	ID 24124
4 x <b>B14</b>	1318 x 42 x 28 mm	ID 26353
2 x <b>B15</b>	1935 x 42 x 28 mm	ID 57824
4 x <b>B16</b>	2018 x 42 x 28 mm	ID 52821
2 x <b>B17</b>	1874 x 52 x 52 mm	ID 26165

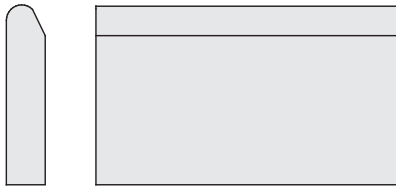

4 x <b>G1</b>	1980 x 95 x 17 mm	ID 48540
---------------	-------------------	----------

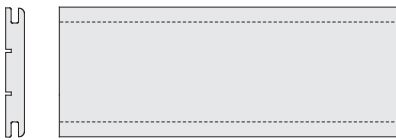

2 x <b>R1</b>	1920 x 82 x 12 mm	ID 23001
---------------	-------------------	----------

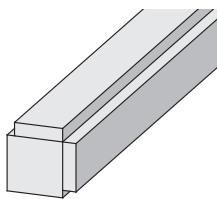

2 x <b>K1</b>	1874 x 64 x 64 mm	ID 24725
---------------	-------------------	----------

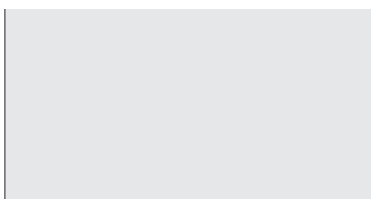

1 x <b>M1</b>	1232 x 606 x 57 mm	ID 99667
2 x <b>M2</b>	1232 x 700 x 57 mm	ID 99668

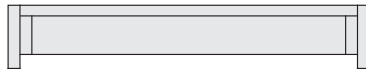

1 x <b>L1</b>	1377 x 500 x 90 mm	ID 25542
1 x <b>L2</b>	1985 x 500 x 90 mm	ID 99669

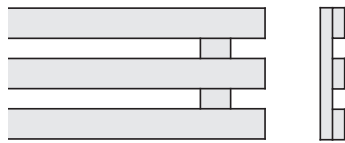

2 x <b>L3</b>	1983 x 174 x 32 mm	ID 38153
---------------	--------------------	----------

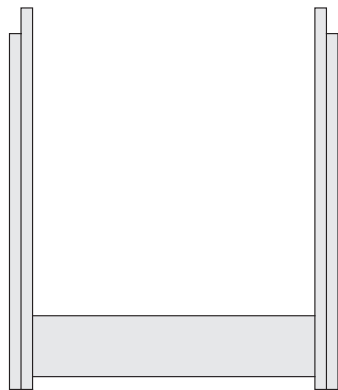

2 x <b>H1</b>	595 x 462 x 95 mm	ID 27555
2 x <b>H2</b>	895 x 462 x 95 mm	ID 10033

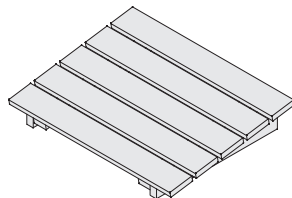

1 x	400 x 300 x 80 mm	ID 99990
-----	-------------------	----------

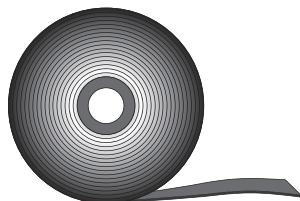

1 x	10 m	ID 14025
-----	------	----------

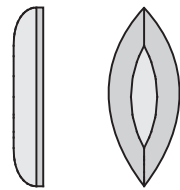

4 x	<b>T1</b>	ID 26272
-----	-----------	----------

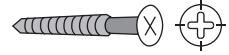

50 x	4 x 30 mm	ID 3686
35 x	4 x 40 mm	ID 21925
60 x	4 x 50 mm	ID 3688
40 x	4 x 70 mm	ID 3689
45 x	4,5 x 80 mm	ID 9204

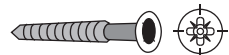

70 x	4,5 x 40 mm	ID 26285
------	-------------	----------

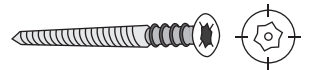

6 x	6 x 80 mm	ID 14266
-----	-----------	----------



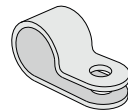

6 x		ID 46403
70 x		ID 26116



1 x		ID 50420
-----	--	----------

 Übersicht  
 Overview  
 enquête

 overzicht  
 undersøgelse  
 estudio

 sondaggio  
 přehled

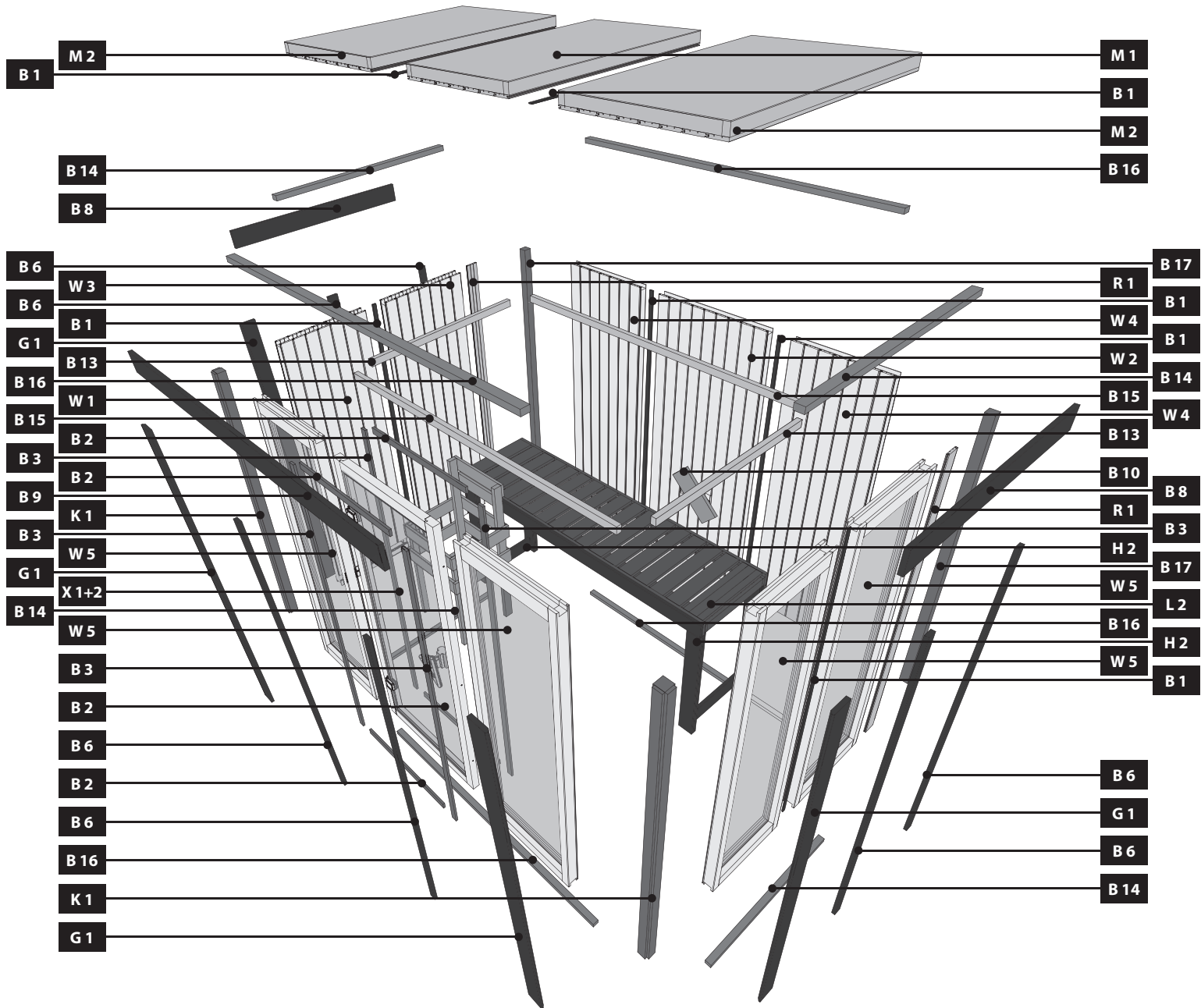

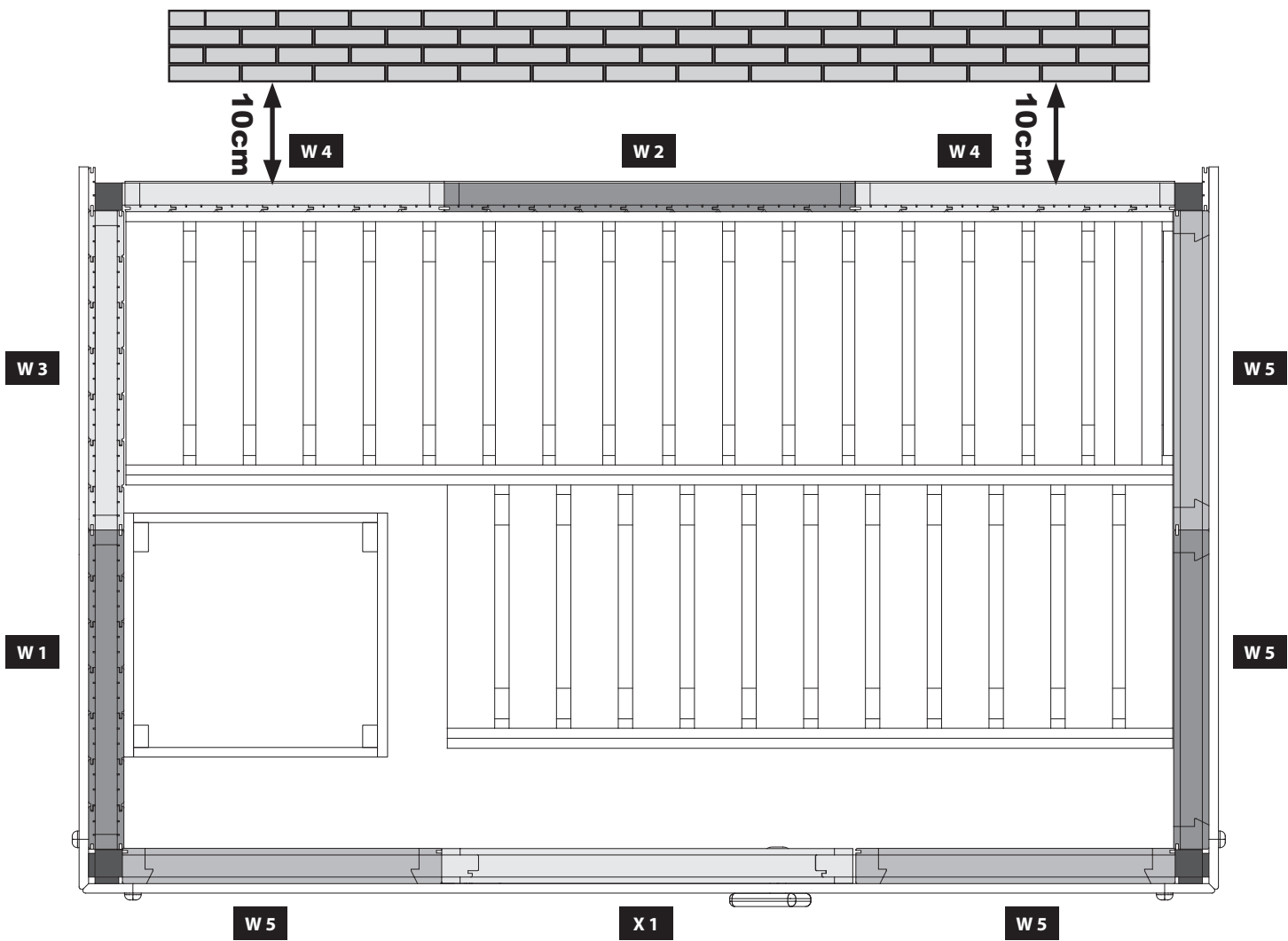

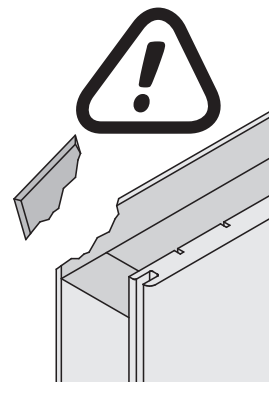
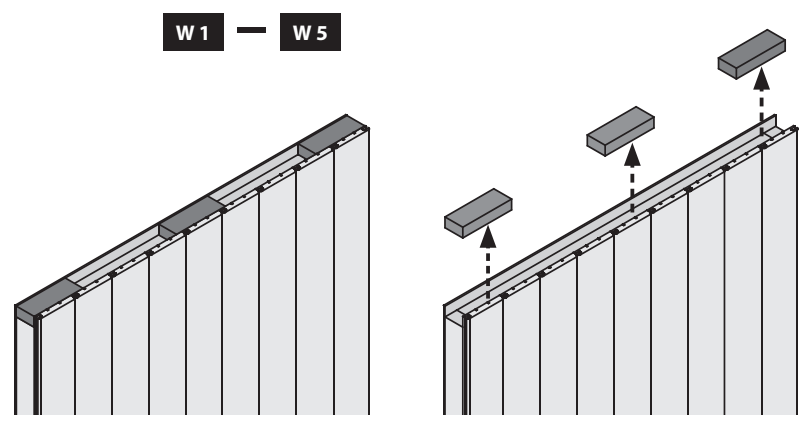
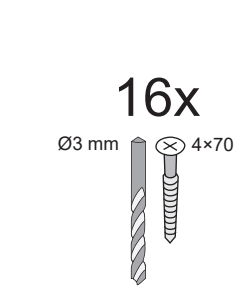
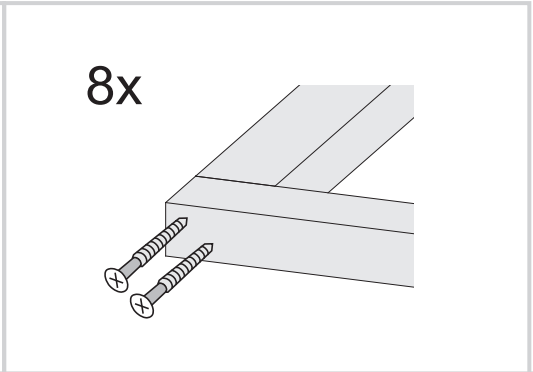
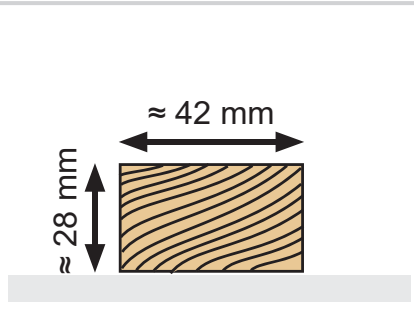
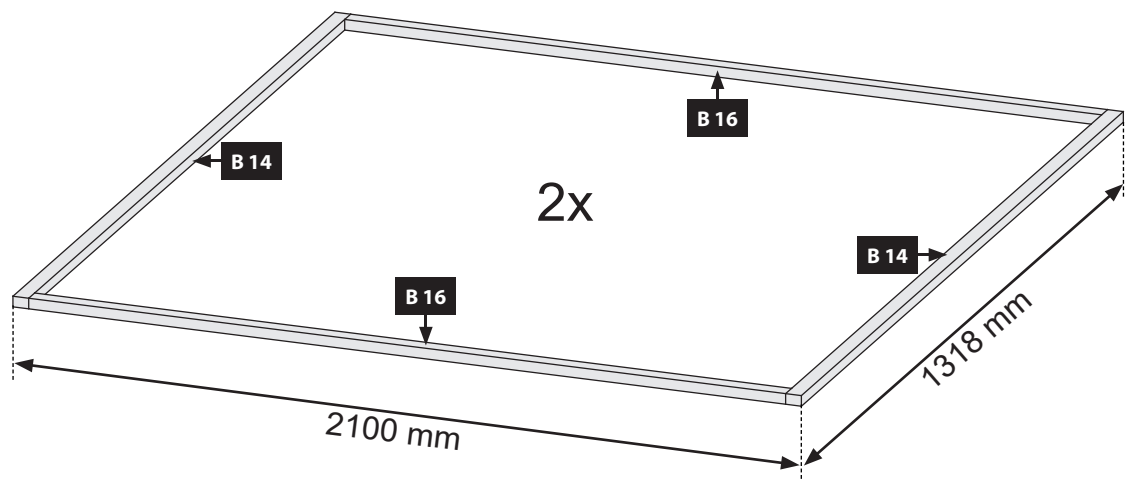



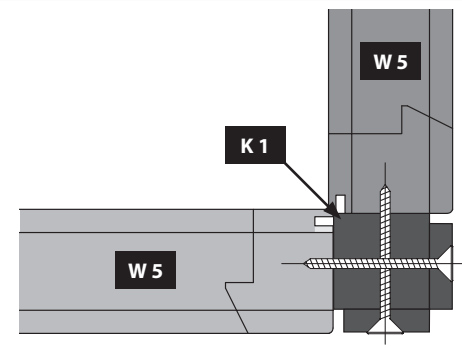
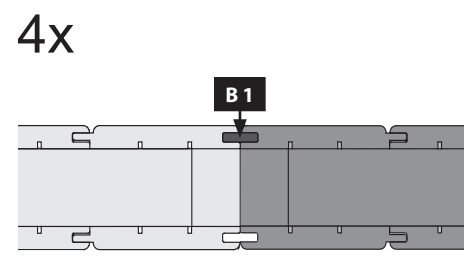
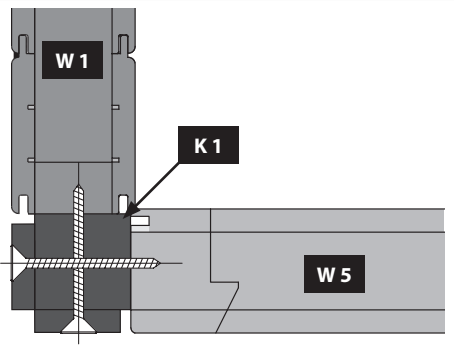
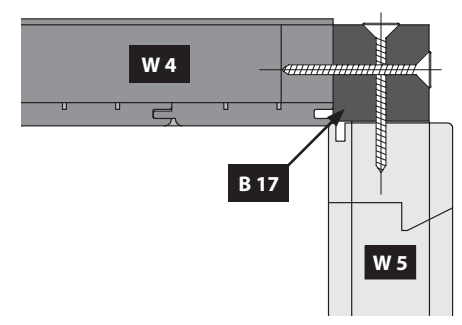
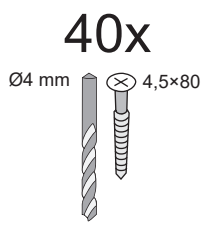
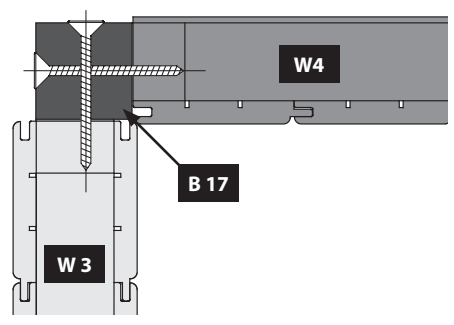
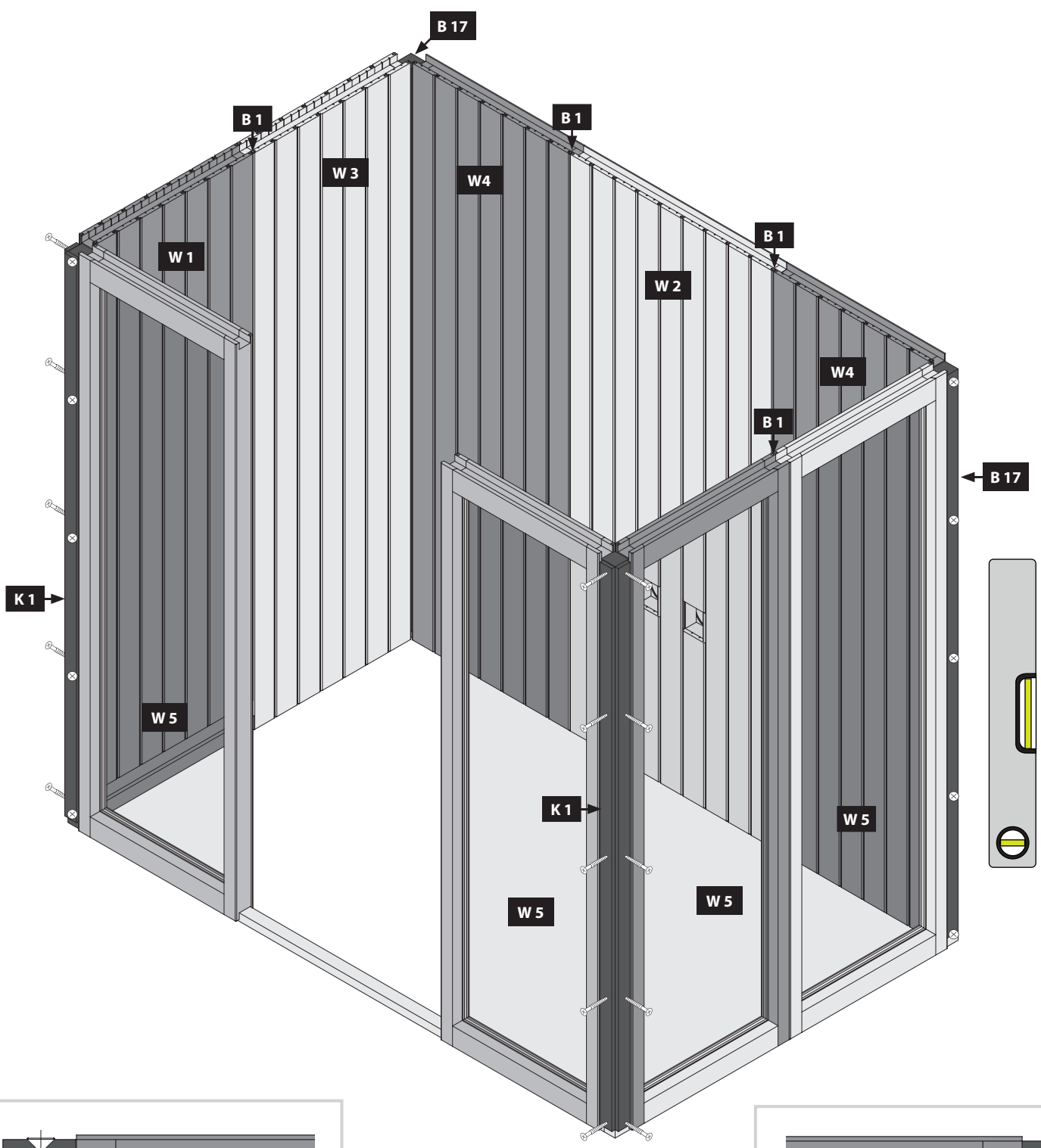

-  Vorsicht!
-  Voorzichtig!
-  Attention!
-  Attention!
-  Cuidado!
-  Occhio!
-  Pozor!
-  Opozorilo!



-  Einbau Glastür
-  Installation of glass door
-  Montage porte en verre
-  Montage van de glazen deur
-  Installationsglasdør

-  Montaje de la puerta de cristal
-  Installazione portello di vetro
-  Sauna Instalace dveře
-  Vgradnja šteklenih vrat

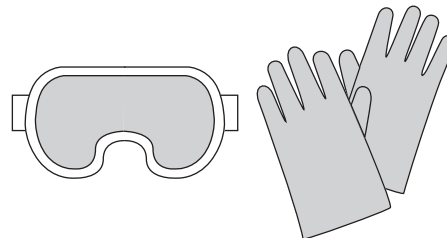

04

-  Tür in den Rahmen legen
-  Put the door in the frame
-  Mettez la porte dans le cadre
-  Plaats de deur in het frame
-  Sæt døren i rammen
-  Pon la puerta en el marco
-  **Metti la porta nel telaio**
-  Vložte dveře do rámu
-  Vrata nameštite v okvir

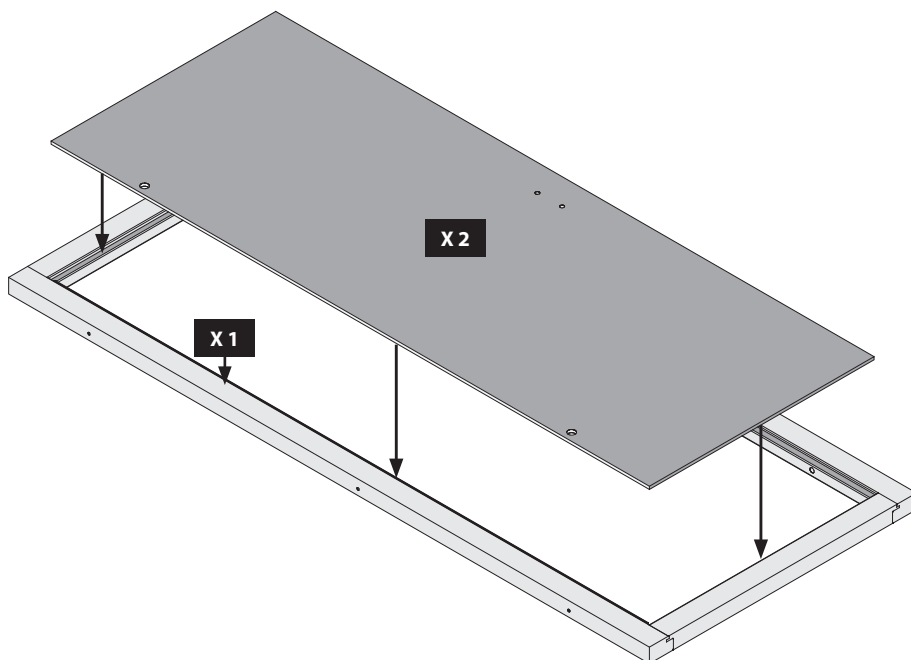

05

-  Tür im Rahmen ausrichten
-  Center the door in the frame
-  Aligner la porte dans le cadre
-  Lijn de deur in het frame uit
-  Juster døren i rammen
-  Alinea la puerta en el marco
-  **Allinea la porta nella cornice**
-  Zarovnejte dveře do rámu
-  Poravnajte vrata v okvir

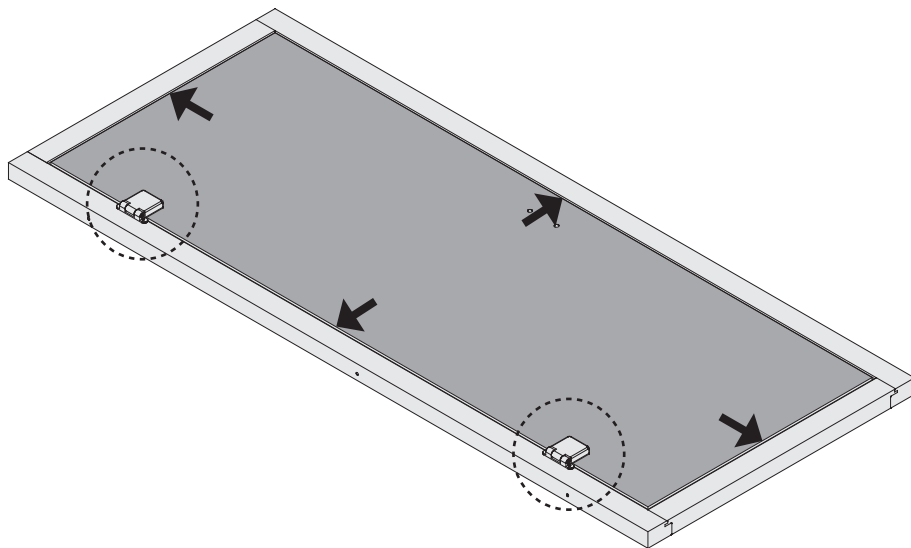

1.

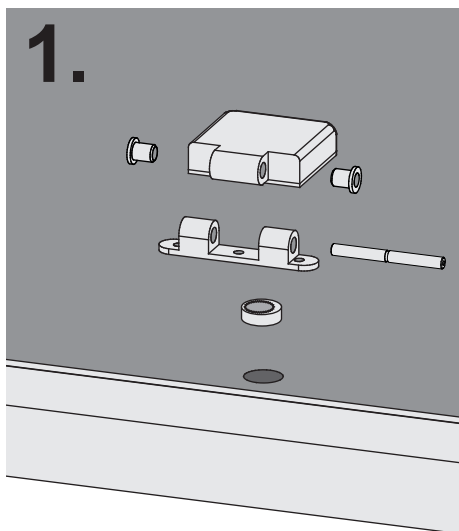

2.

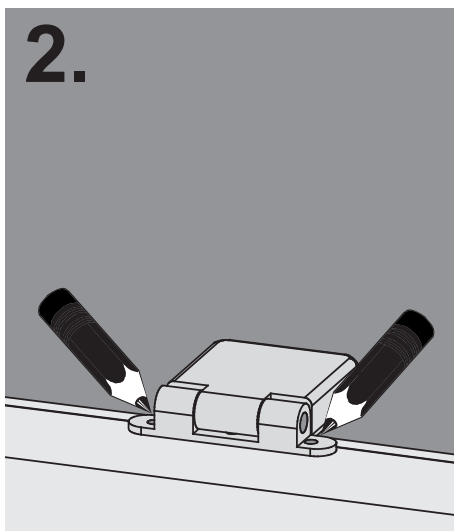

3.

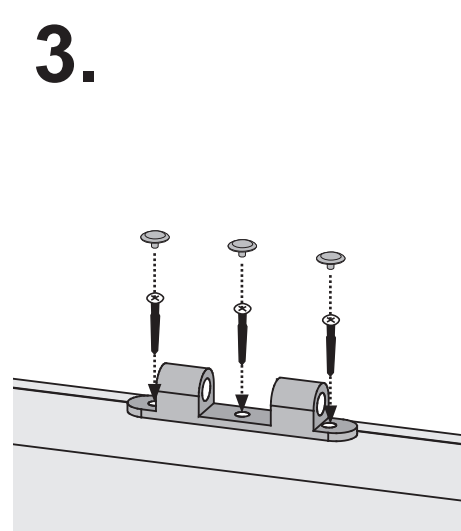

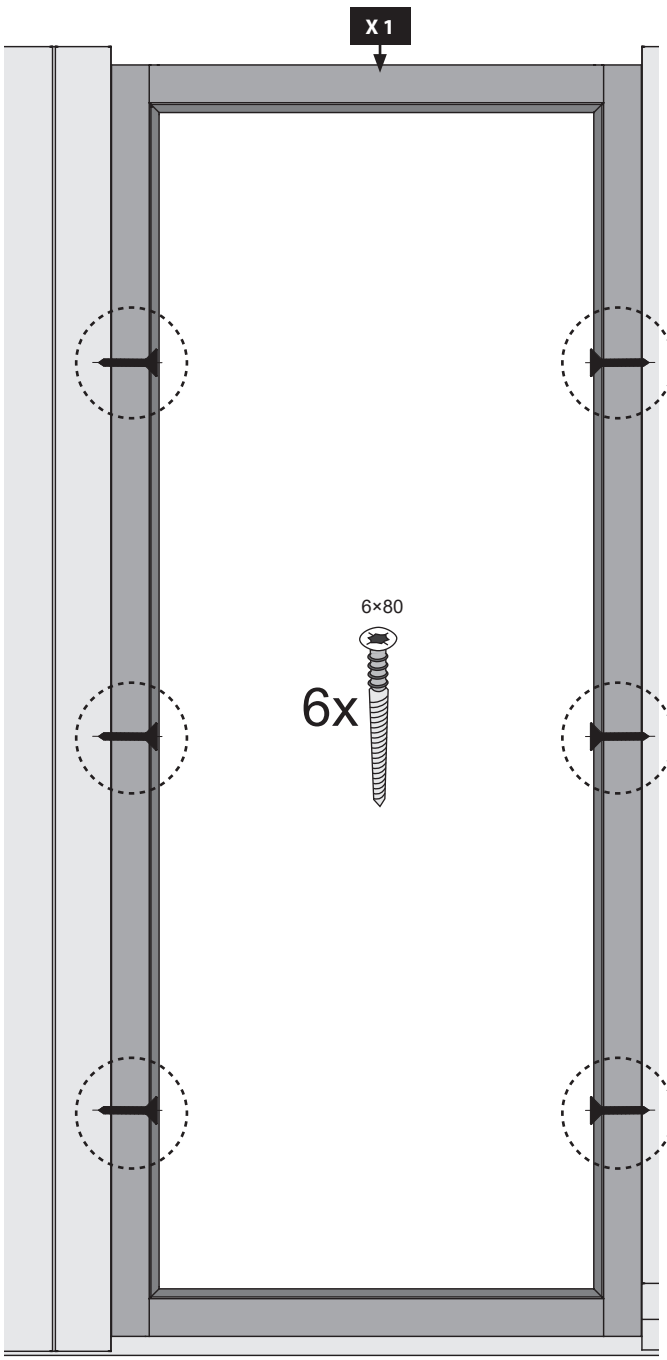
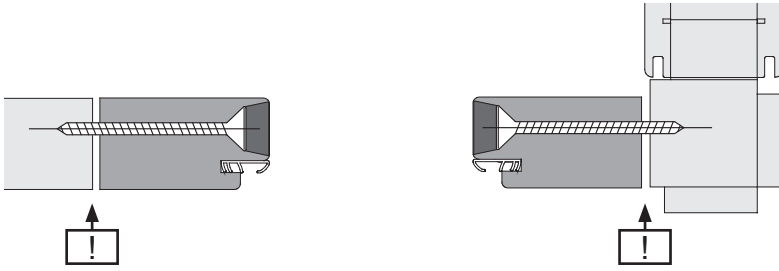



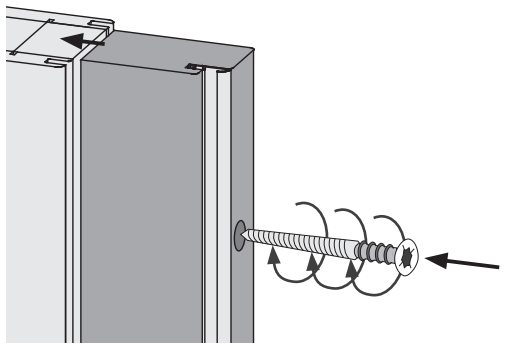



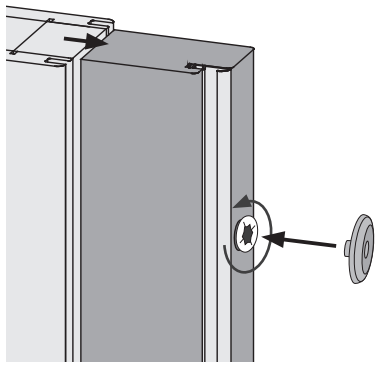

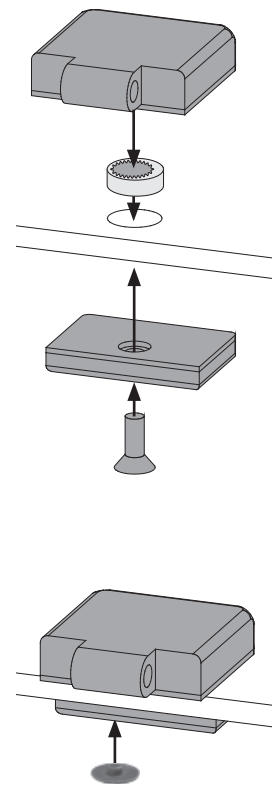
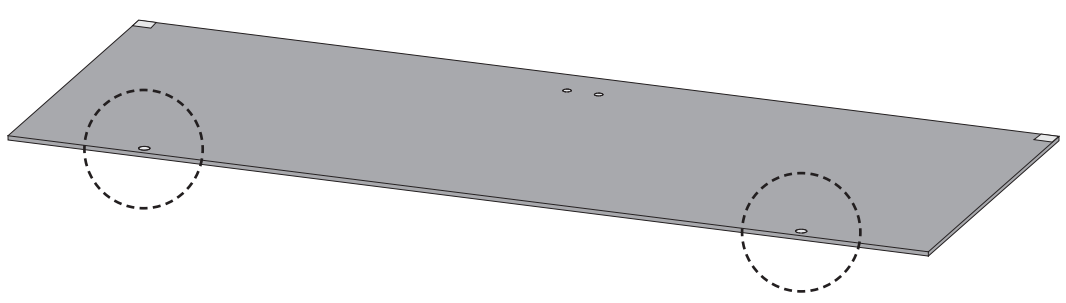
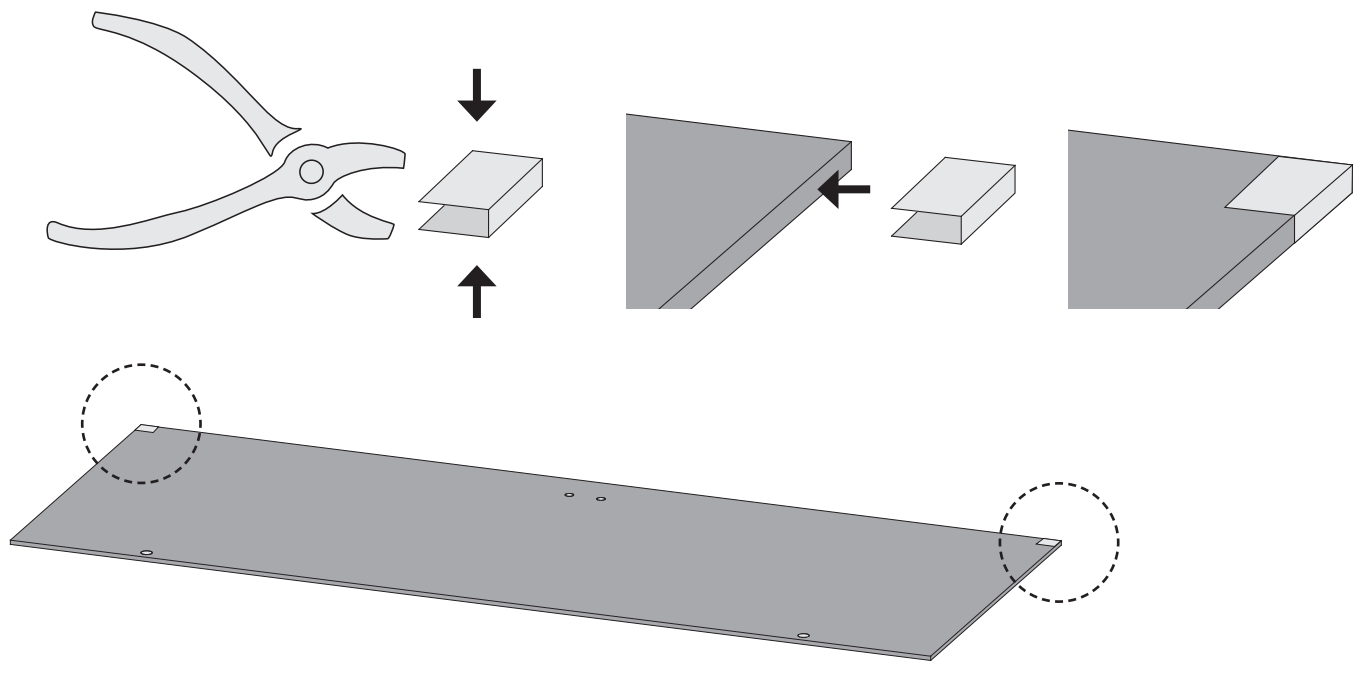

1.









2.

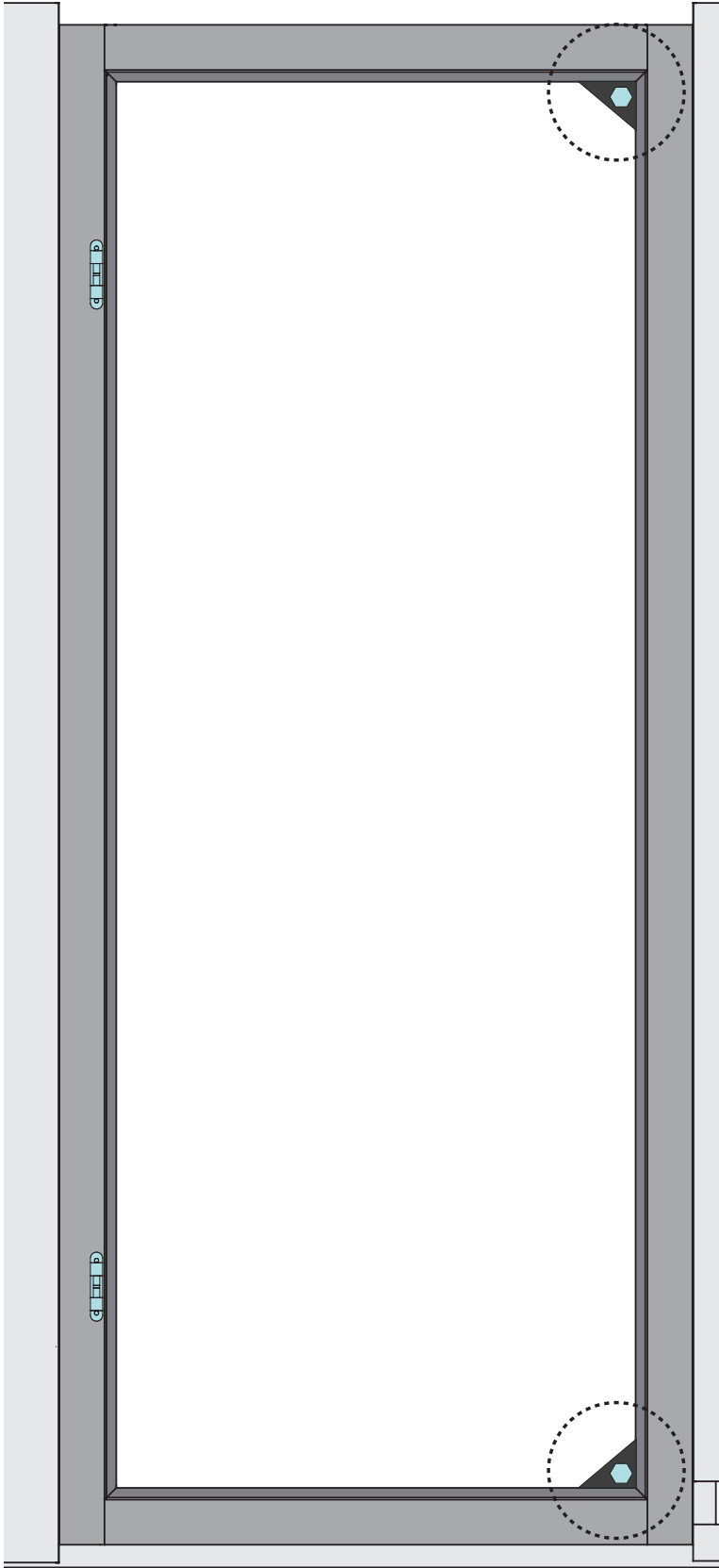







-  Alle Verstell-Excenter müssen in der Glasscheibe die gleiche Grundstellung haben
-  All adjustable eccentrics must have the same basic adjustment in the glass panel
-  Tous les excenteurs de positionnement doivent avoir la même position de base dans la vitre
-  Alle excentrische verstelelementen moeten in dezelfde stand in de glasplaat worden geplaatst
-  Alle justeringsexcentricer skal have samme grundlæggende position i glasruden
-  Todos los excéntricos regulables tienen que tener la misma posición base en la hoja de cristal
-  Tutti gli eccentrici di regolazione devono avere la stessa posizione base nella lastra di vetro
-  šechny nastavovací podivínů musí mít stejný základní polohy ve skle
-  Vsi nastavitveni ekscentri morajo imeti enak osnovni položaj v steklu.



-  Alle Verstell-Excenter müssen in der Glasscheibe die gleiche Grundstellung haben
-  All adjustable eccentrics must have the same basic adjustment in the glass panel
-  Tous les excentreurs de positionnement doivent avoir la même position de base dans la vitre
-  Alle excentrische verstelelementen moeten in dezelfde stand in de glasplaat worden geplaatst
-  Alle justeringsexcentricer skal have samme grundlæggende position i glasruden

-  Todos los excéntricos regulables tienen que tener la misma posición base en la hoja de cristal
-  Tutti gli eccentrici di regolazione devono avere la stessa posizione base nella lastra di vetro
-  Šechny nastavovací podivínů musí mít stejný základní polohy ve skle
-  Vsi nastavitveni ekscentri morajo imeti imeti enak osnovni položaj v steklu

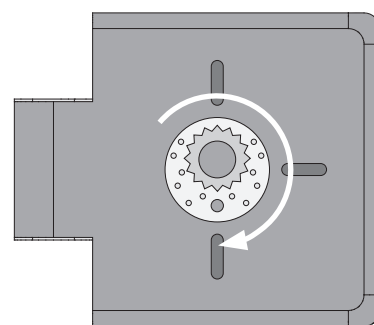
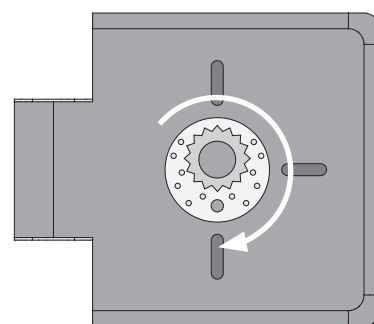
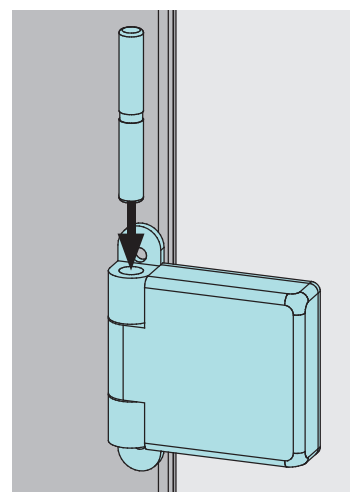
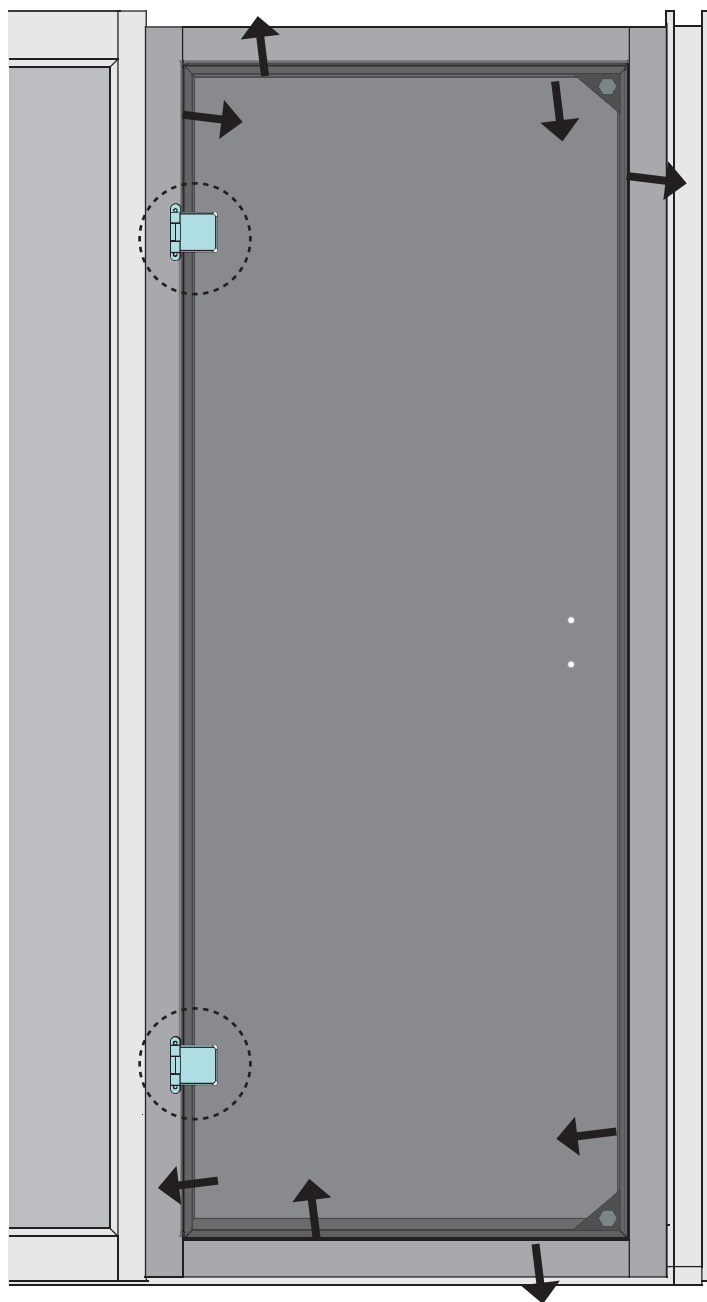

1.

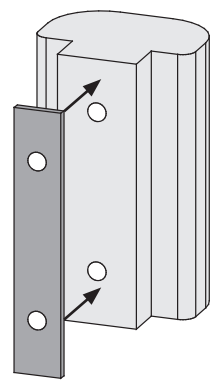

2.

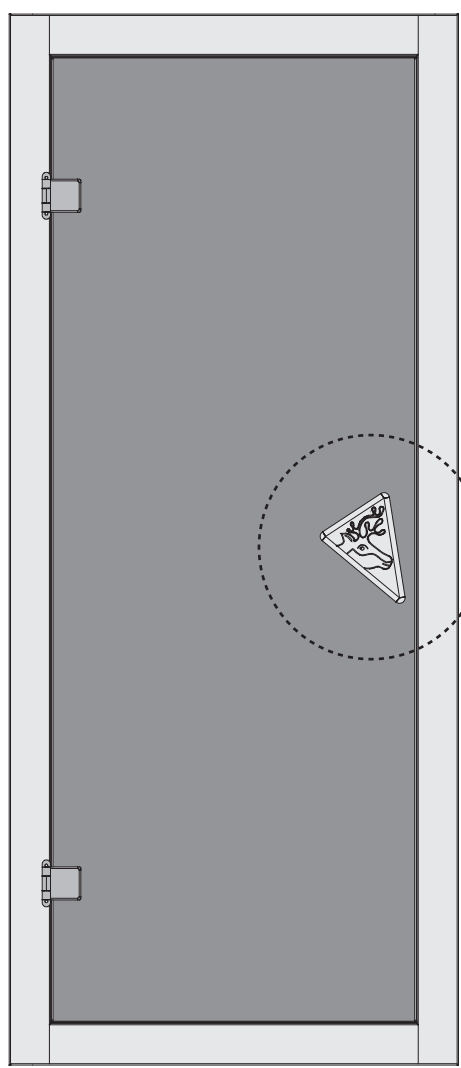
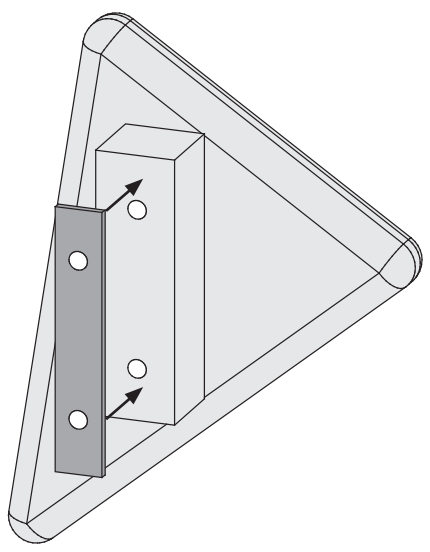

3.

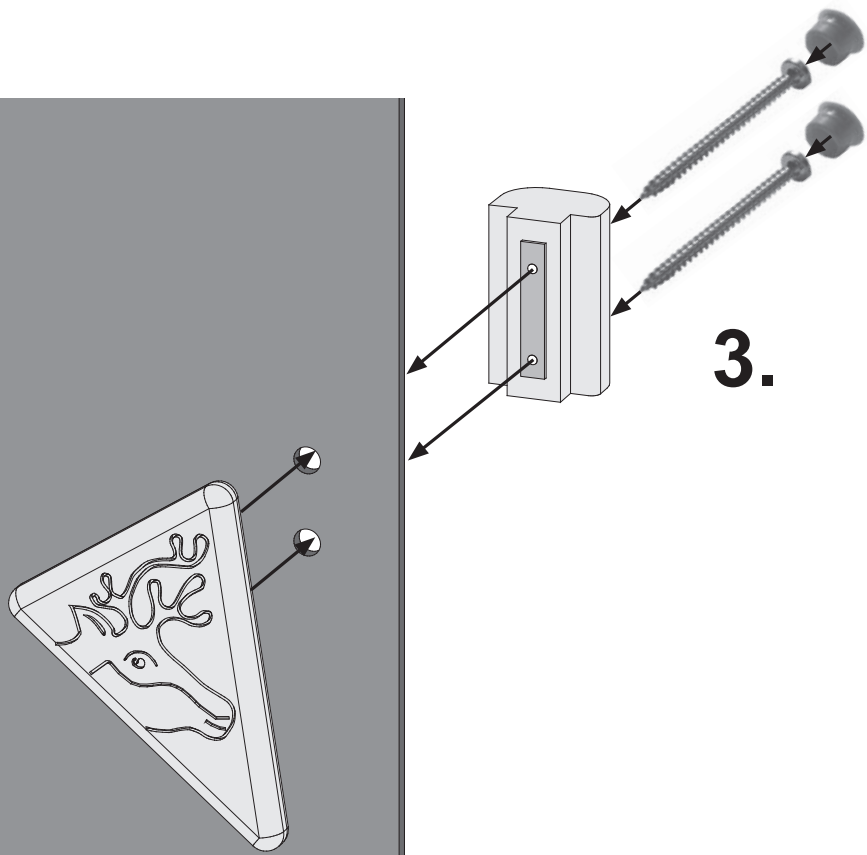

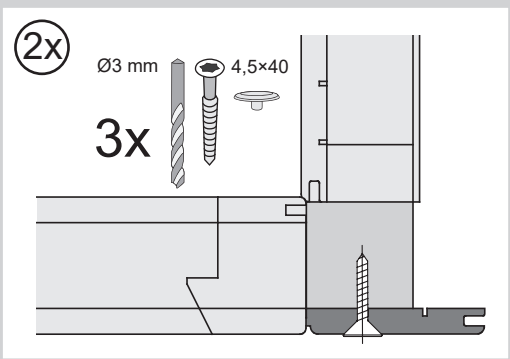
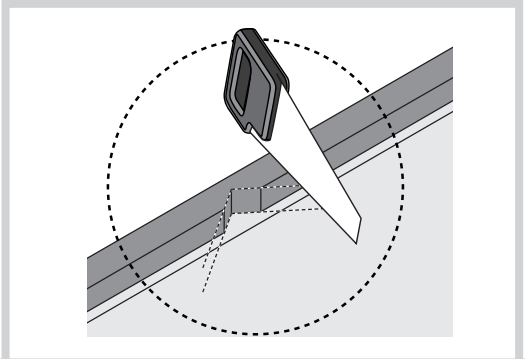
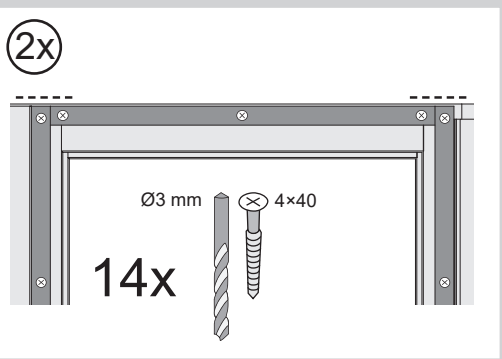
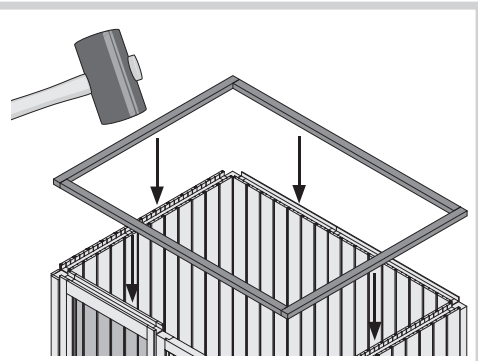
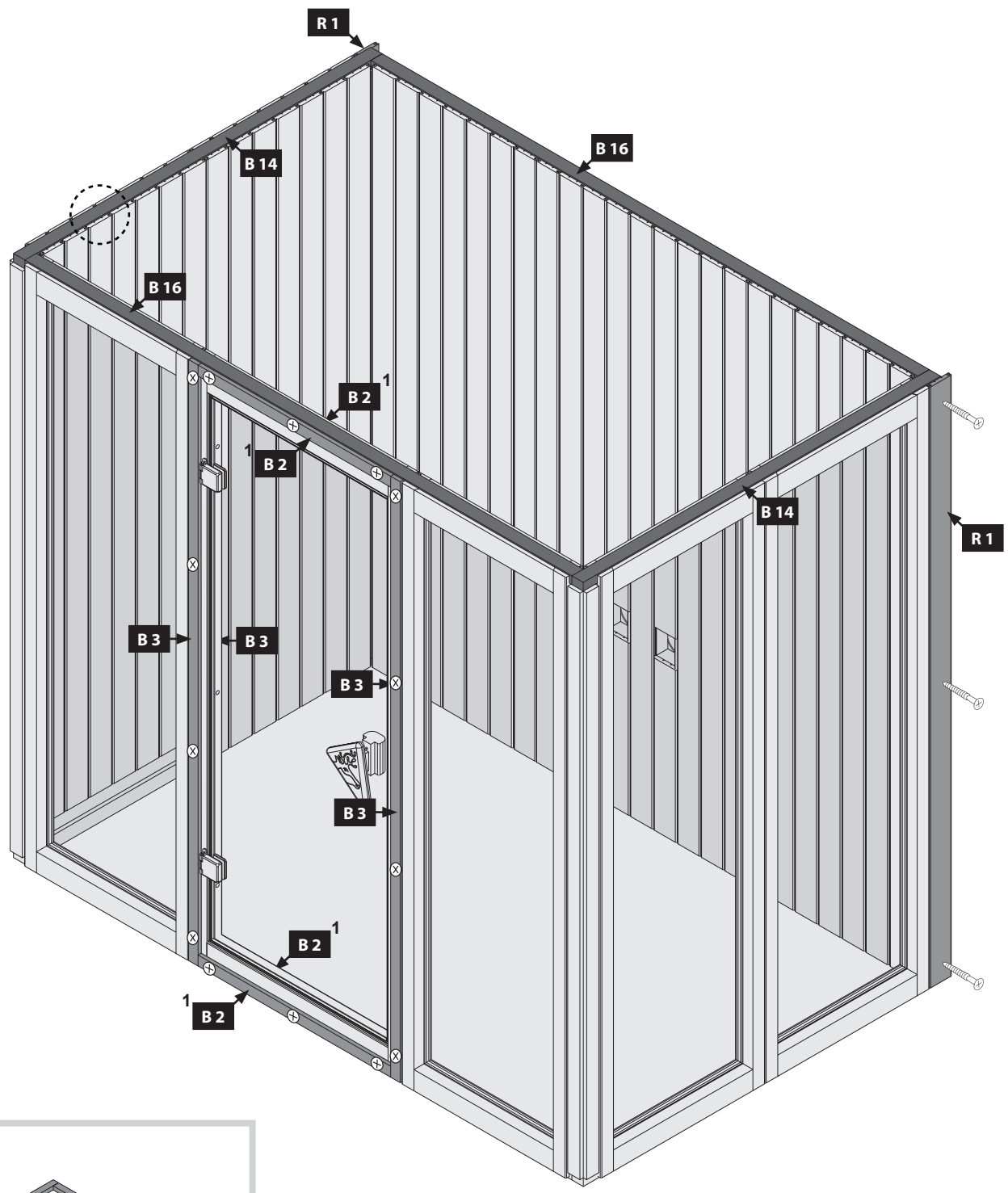

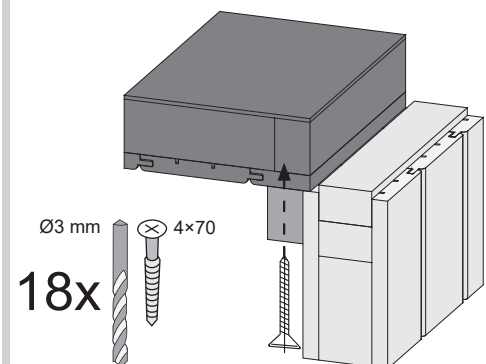
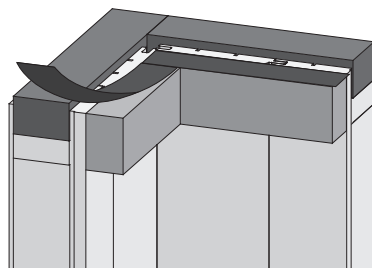
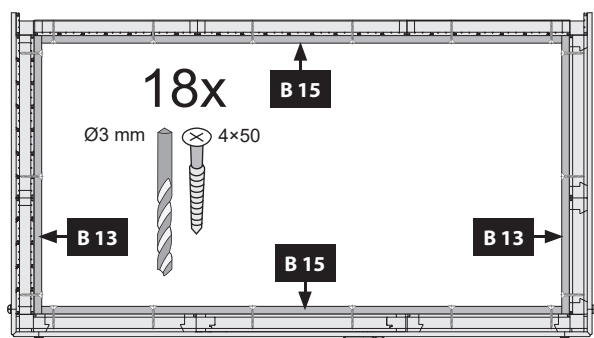
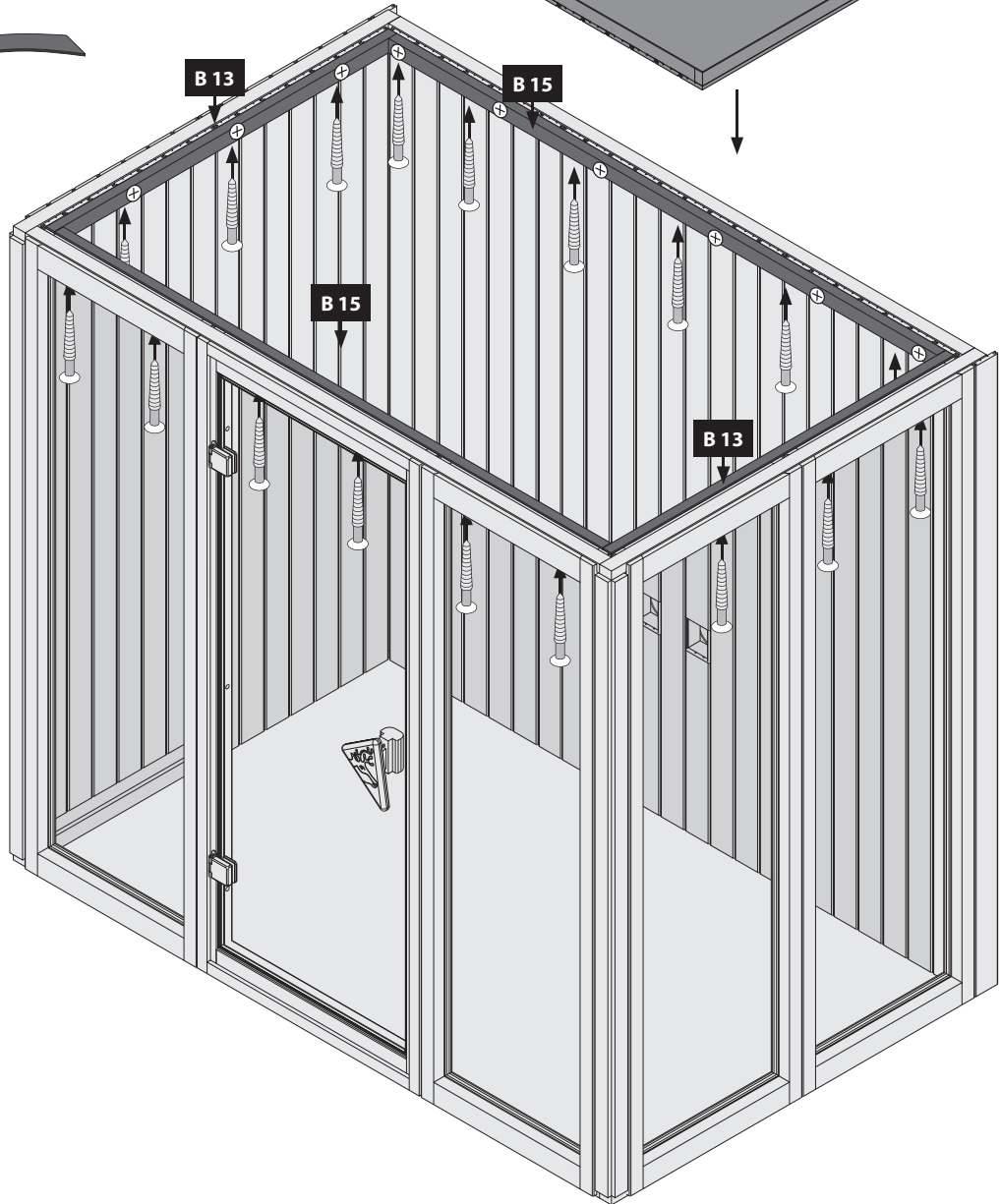
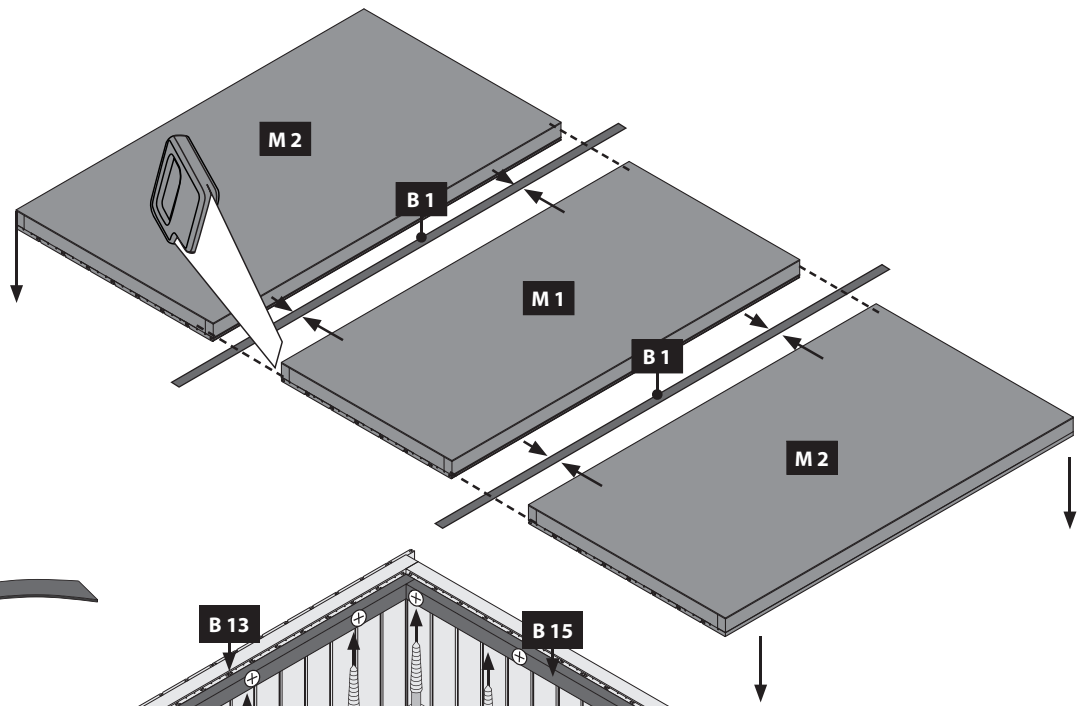
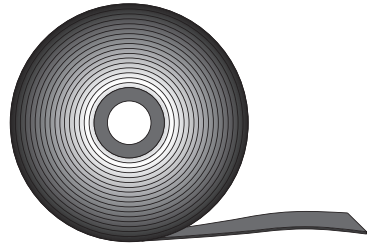

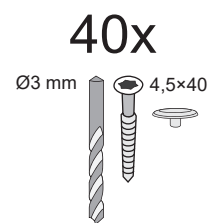
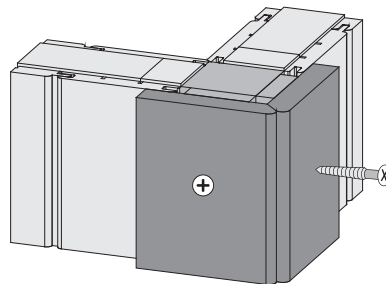
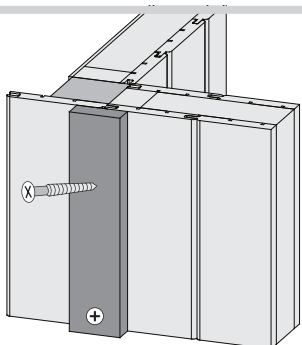
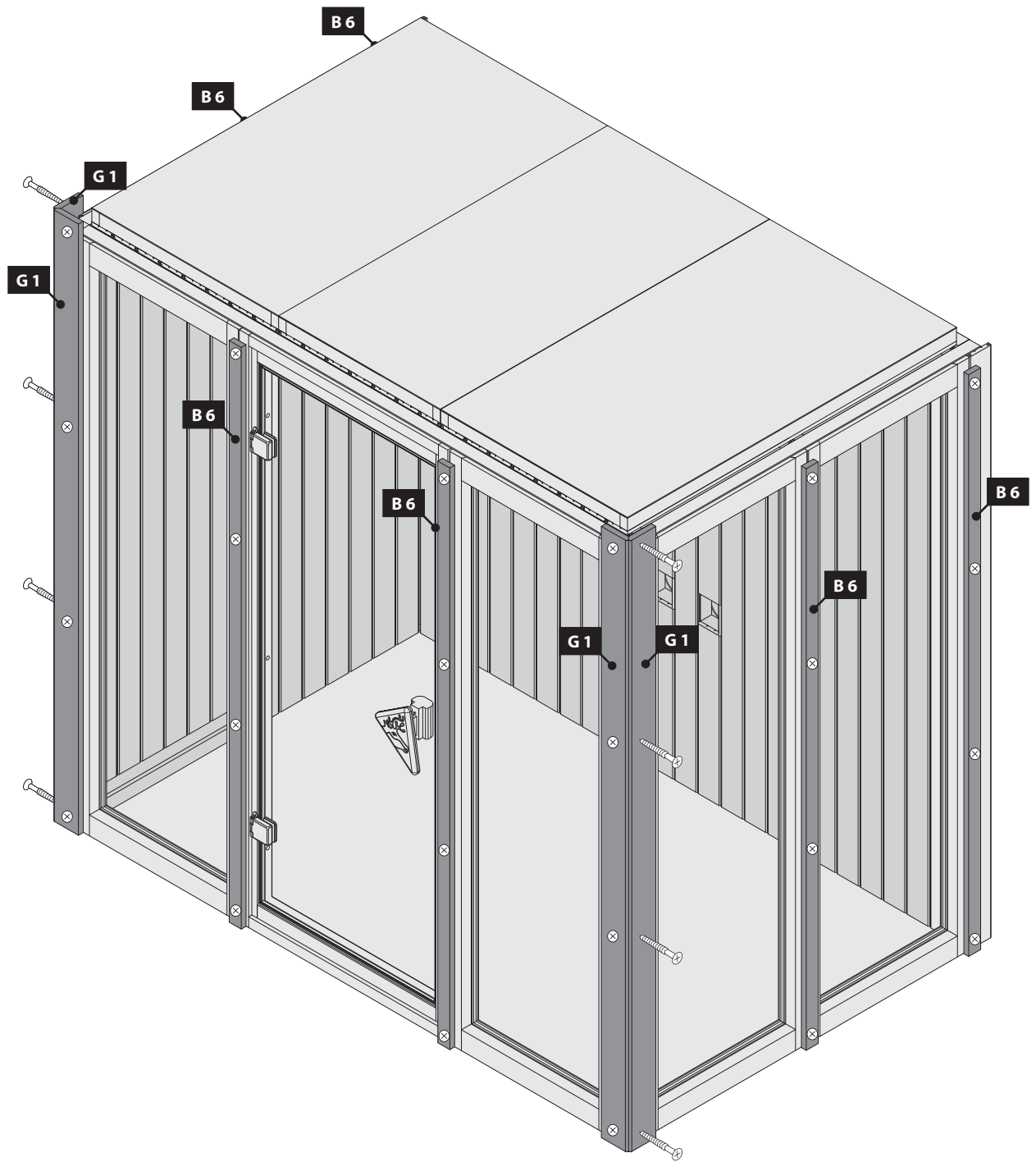

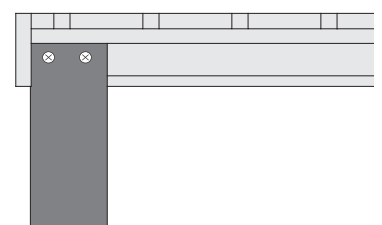
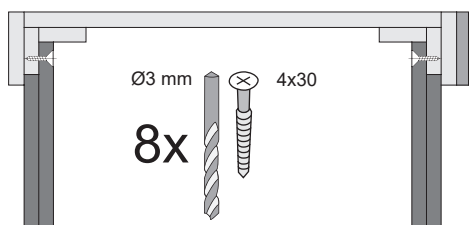
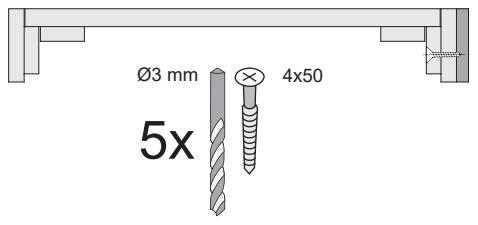
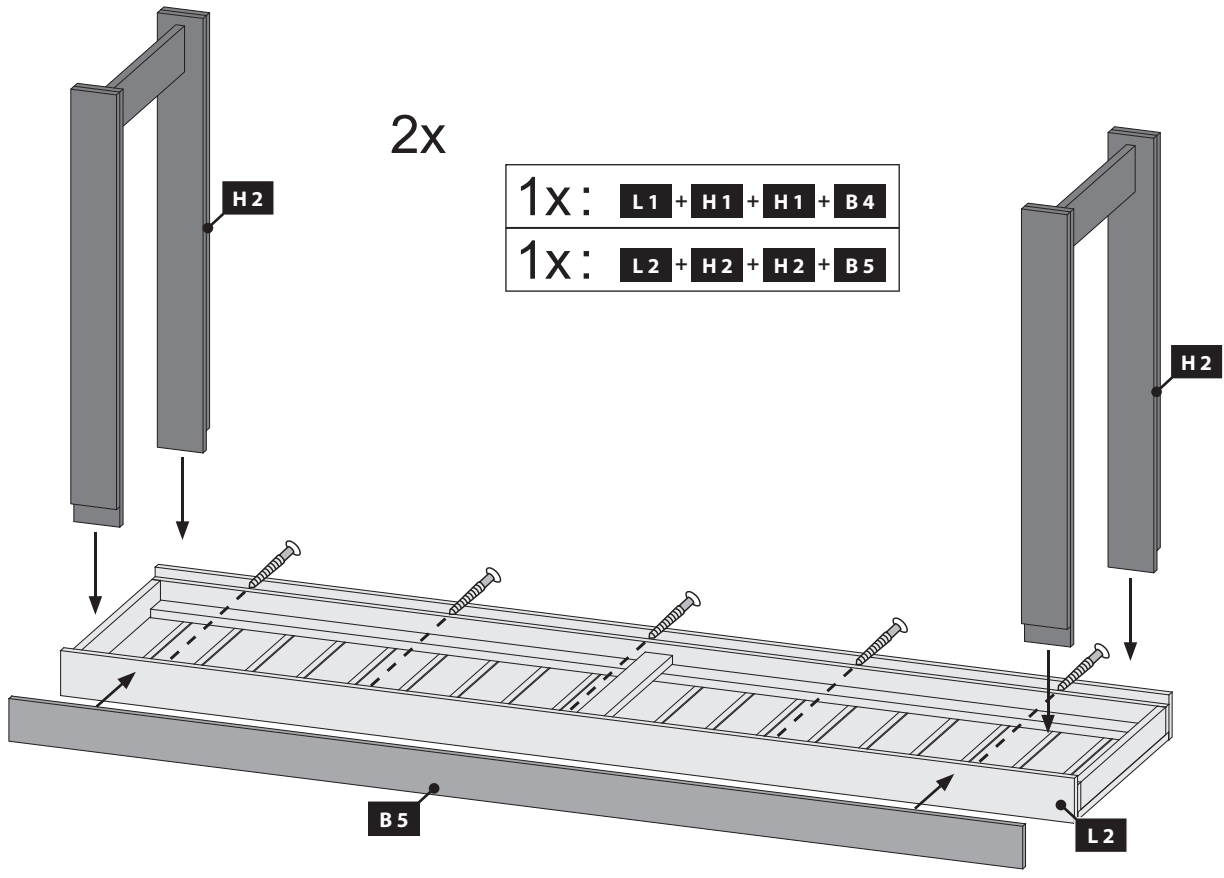
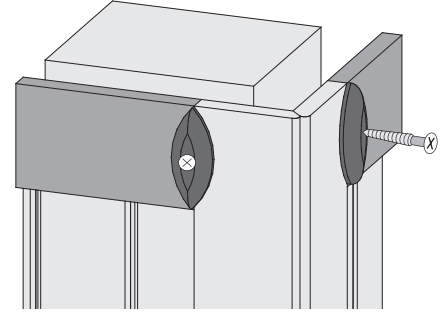
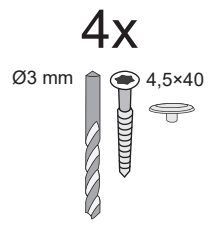
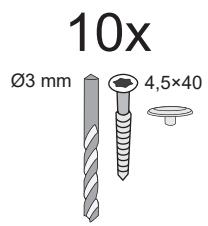
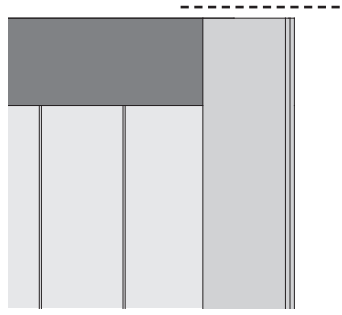
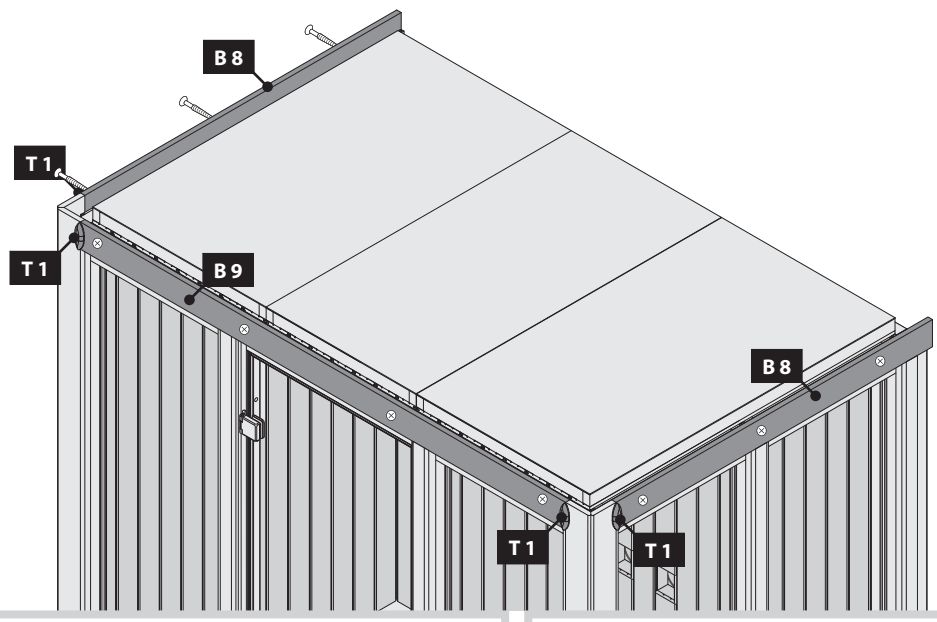

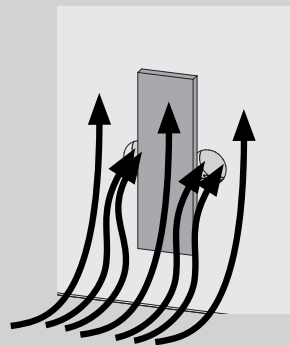
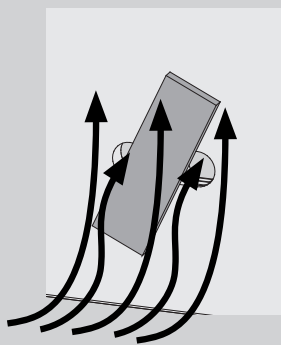
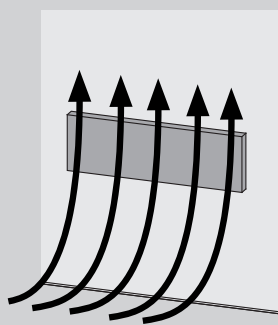
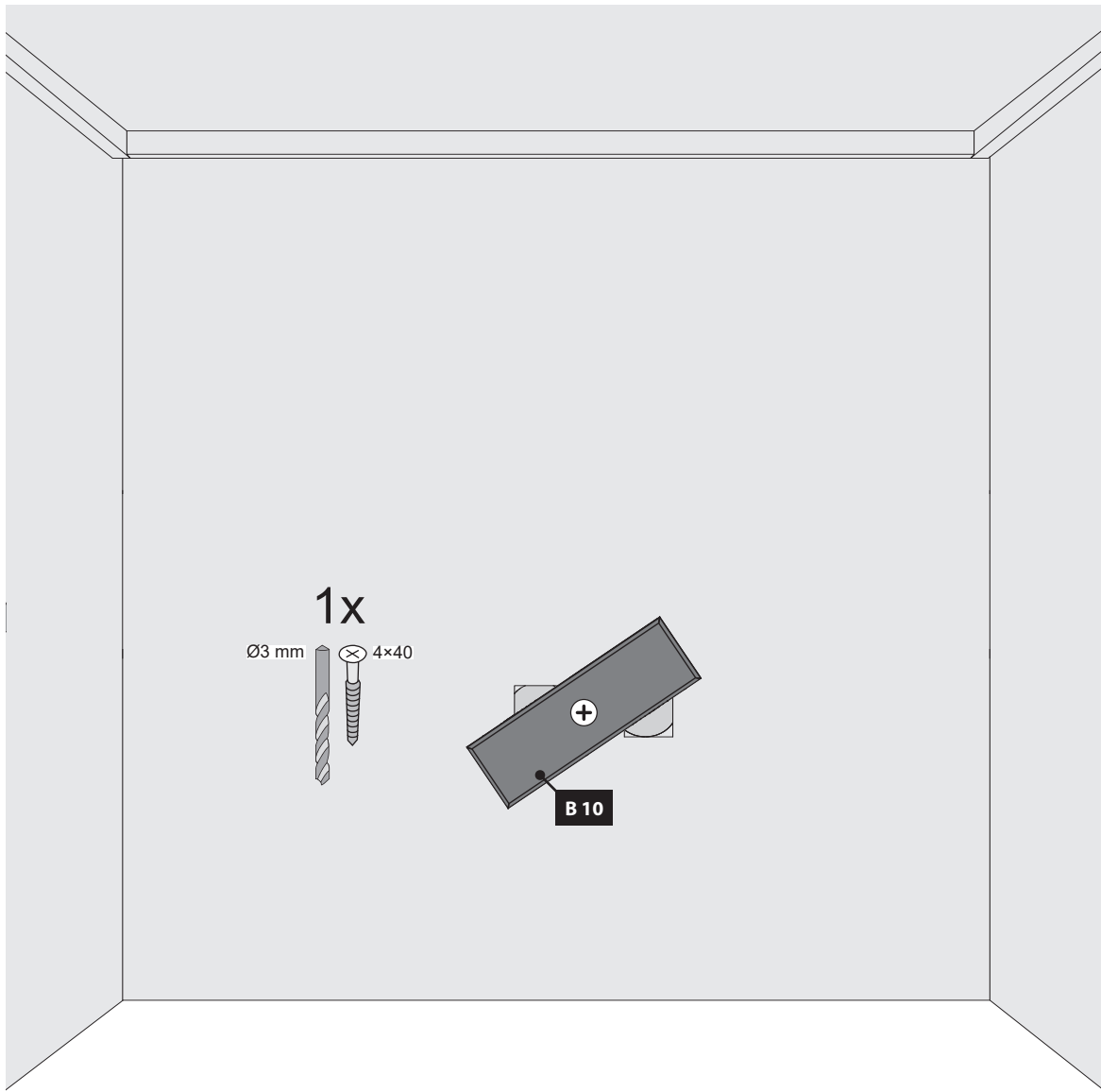







 Hier ist die Funktionsweise des Brettes abgebildet. Regeln Sie damit die Abluft nach Ihren eigenen Wünschen

 This figure shows the functional principle of the board. Regulate the exhaust air according to your own wishes

 Ceci représente le mode de fonctionnement de la planche. Avec elle, réglez l'écoulement de l'air selon vos désirs.

 Hier is de werking van het plankje afgebeeld. Regel daarmee de luchtafvoer naar eigen wens

 Sådan fungerer styret. Brug den til at regulere udstødningsluften efter dine egne ønsker

 Aquí está representada la forma de funcionamiento de la tabla. Regule con ello el aire de salida según sus propios deseos

 Viene illustrato il principio di funzionamento della tavoletta di regolazione della ventilazione. Con essa si può regolare a piacere la ventilazione

 Zde je zobrazená funkce desky. Regulujte s ní odsávací vzduch dle Vašeho přání

 Tukaj si lahko ogledate delovanje plošče. Z njo lahko uravnate izpušni zrak po lastnih željah.

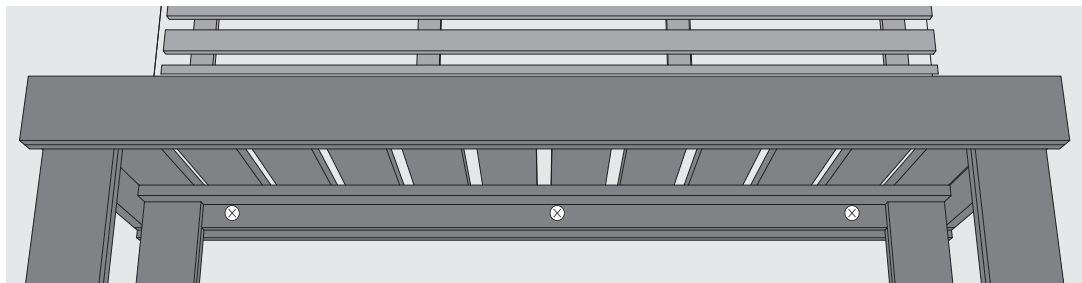
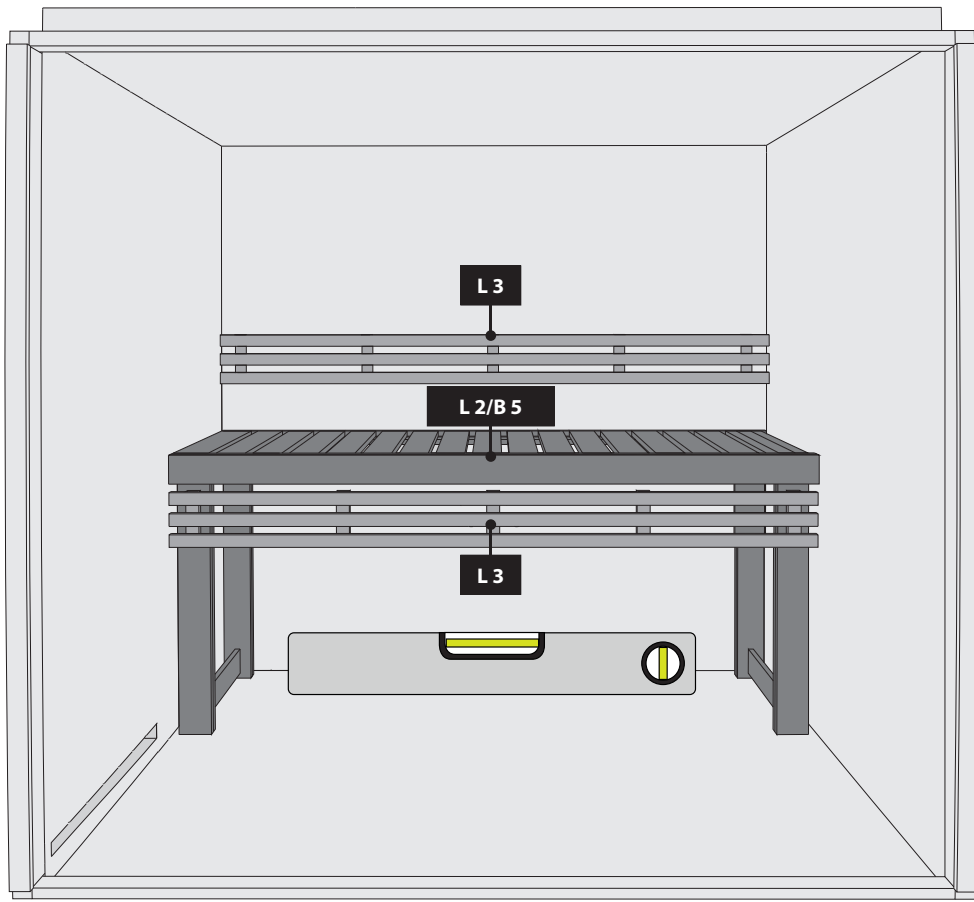

3x  
Ø3 mm 4x50

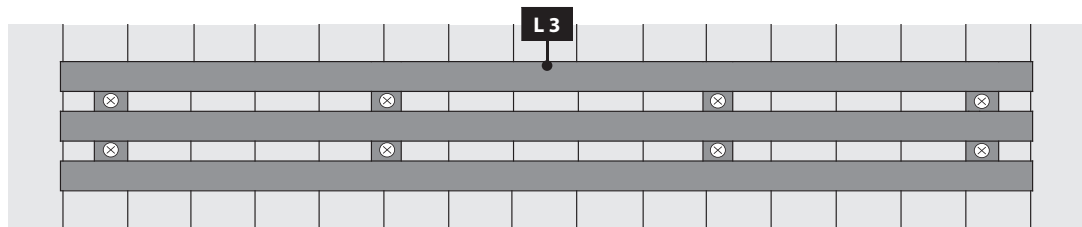

8x  
Ø3 mm 4x30



6x  
Ø3 mm 4x30

4x  
Ø3 mm 4x50

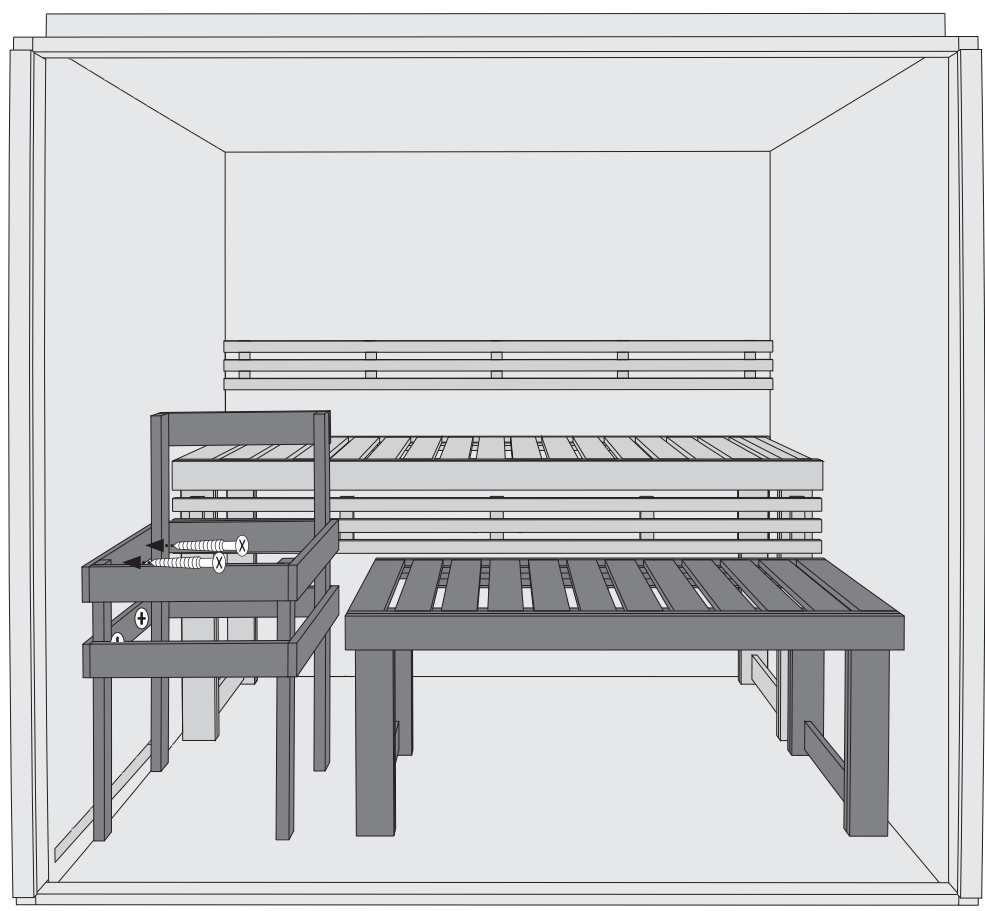

4x Ø3 mm 4x50  
16x Ø3 mm 4x30



2x

8x  
Ø3 mm 4x50

