

97568

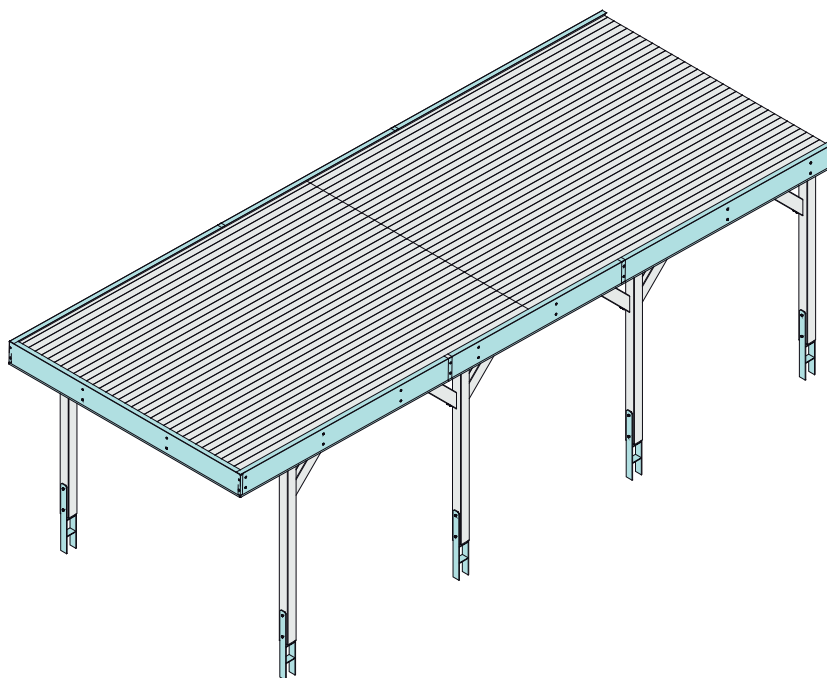

-  **Aufbauanleitung**
-  **Building Instructions**
-  **notice de montage**
-  **montagehandleiding**
-  **Montagevejledning**
-  **Instrucciones de construcción**
-  **Istruzioni per il montaggio**
-  **Montážní návod**
-  **Navodila za sestavljanje**

Bitte bewahren Sie die Anleitung und den Garantieschein zur Seriennummer auf.

Vernichten Sie diese erst nach Ablauf der Garantiezeit.

Eventuelle Beanstandungen können mithilfe der Stückliste einfacher zugeordnet werden.

Beigelegte Dokumente

- Informationsheft
- Garantieschein zur Seriennummer
- Typenschild inkl. Warnhinweise (Sauna)
- ggf. Zubehör-Anleitungen in externen Paketen

*

 Nicht im Lieferumfang enthalten

 Not included

 Non comprises dans la livraison

 Niet bijgeleverd

 No forman parte del suministro

 Non incluso

 V ceně není zahrnuto

 Ikke inkluderet

 Ni vključeno v obseg dobave

2

 Nicht gebraucht

 Not needed

 Pas nécessaire

 Niet nodig

 No es necesario

 Non necessario

 Není nutná

 Ikke nødvendigt

 Ne uporablja se

4

 Fixiert vorübergehend

 Fixed temporarily

 Temporairement fixe

 Tijdelijk vast

 Temporalmente fijo

 Temporaneamente fisso

 Dočasně pevný

 Midlertidigt rettet

 Začasno popravi

1

 Länge muss ermittelt und zugesägt werden

 Length must be determined and sawn

 La longueur doit être déterminée et sciée

 De lengte moet worden bepaald en worden gezaagd

 La longitud debe ser determinada y aserrada

 La lunghezza deve essere determinata e segata

 Délka musí být určena a rozřezána

 Længden skal bestemmes og saves

 Določiti je treba dolžino in jo odrezati po velikosti.

3

 Mit Zubehör

 With accessories

 Avec accessoires

 Met toebehoren

 Con accesorios

 Con accessori

 S příslušenstvím

 Med tilbehør

 Z dodatki

5

 Bestand vom Haus

 Inventory of the house

 Inventaire de la maison

 Inventaris von het huis

 Inventario de la casa

 Inventario della casa

 Inventář domu

 Inventar af huset

 Inventarizacija hiše

 Vergleichen Sie zuerst die Material-liste mit Ihrem Paketinhalt! Bitte haben Sie Verständnis, dass Beanstandungen nur im nicht aufgebauten Zustand bearbeitet werden können!

 First compare the list of materials with your package contents! Please understand that complaints can be processed in the non-built status only!

 Commencez par comparer la liste du matériel avec le contenu de votre paquet! Sachez que nous traitons uniquement les réclamations concernant le matériel à l'état non monté!

 Vergelijk eerst de lijst van materialen met de inhoud van uw pakket! Reclamaties kunnen alleen in behandeling worden genomen zolang de onderdelen nog niet zijn gemonteerd!

 Start med at kontrollere materialelisten med indholdet af den leverede pakke! Vi gør venligst opmærksom på at reklamationer kun kan behandles for materialer som ikke er blevet bearbejdet!

 En primer lugar, compare la lista de material con el contenido del paquete. Rogamos entienda que las reclamaciones sólo pueden ser tramitadas antes de montar el objeto!

 Confrontate questa distinta materiali prima con il contenuto del pacchetto! Vi preghiamo di comprendere che eventuali reclami possono essere accolti solo prima del montaggio!

 Nejprve přezkontrolujte obsah balení podle materiálového listu! Mějte pochopení pro to, že případnou reklamaci se můžeme zabývat pouze tehdy, když díly nebudou smontované! Za pomoci tohoto seznamu můžete jednotlivé díly přiřadit k montážnímu návodu.

 Najprej primerajte zoznam materialov z vsebino vašega paketa! Upoštevajte, da lahko pritožbe obravnavamo le v nesestavljenem stanju!

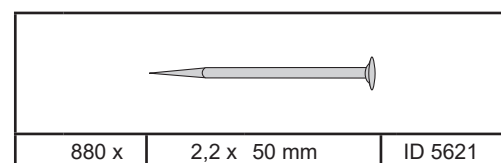
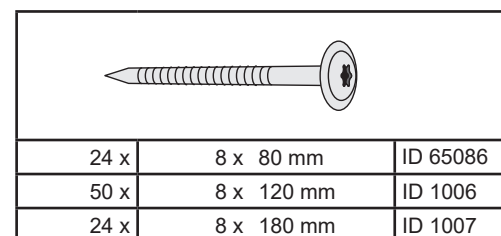
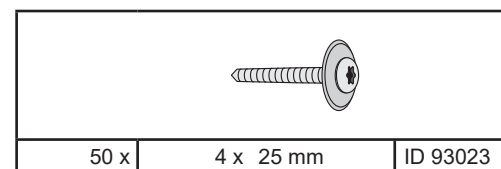
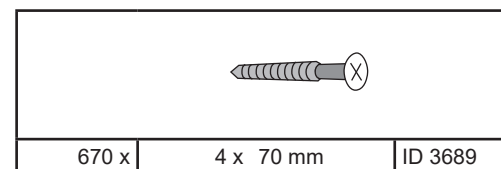
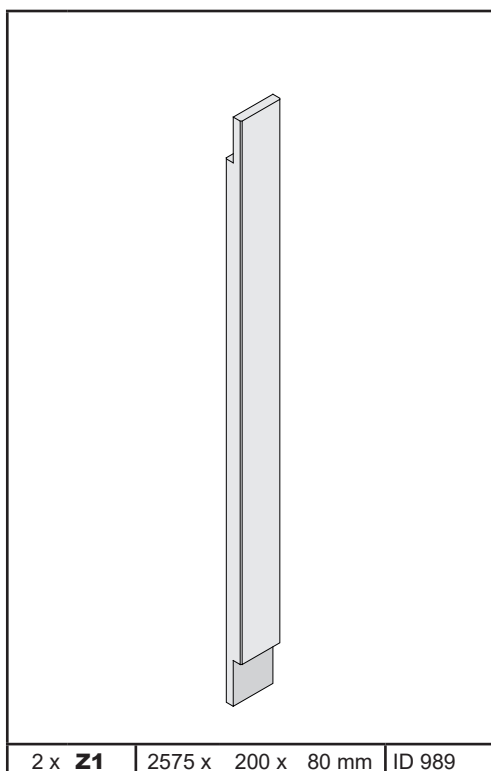
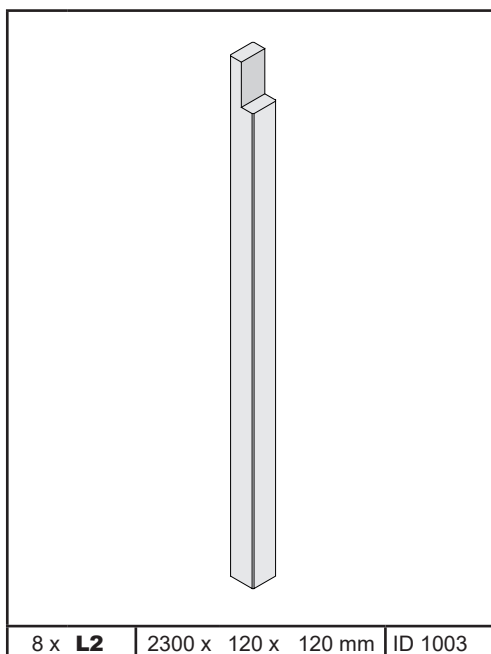
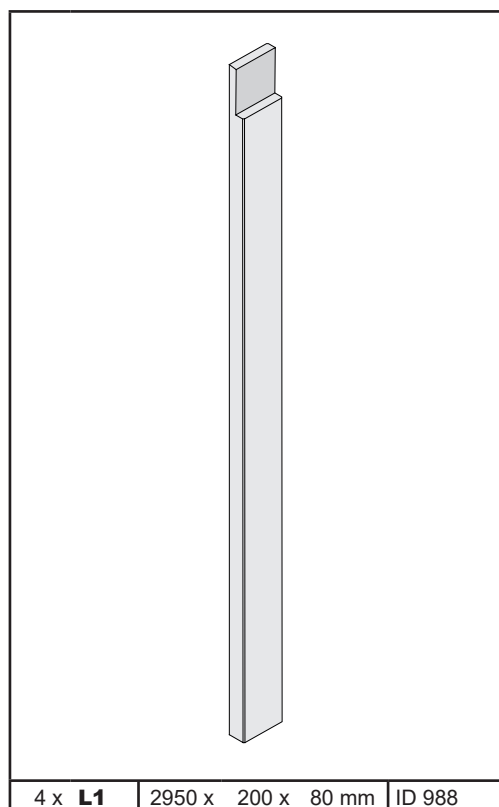
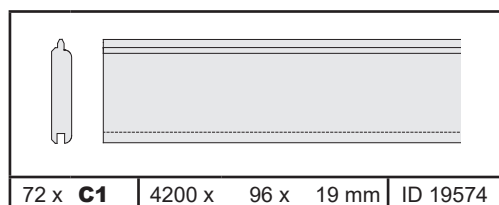
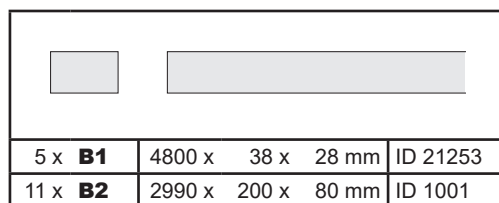
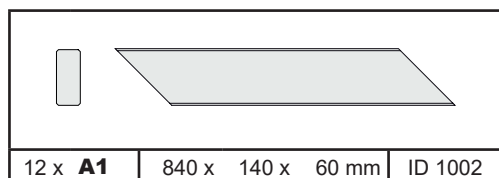

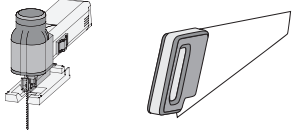
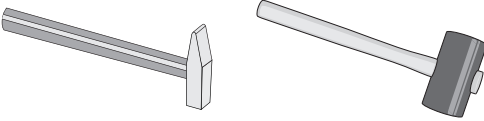
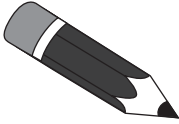
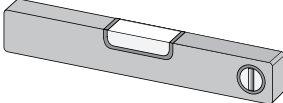
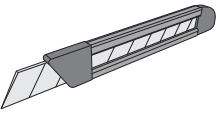
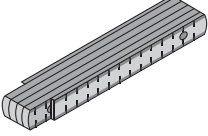
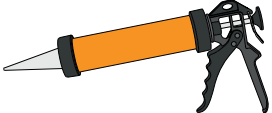
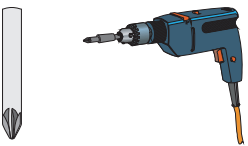
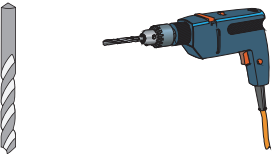
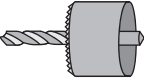
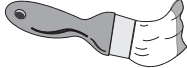

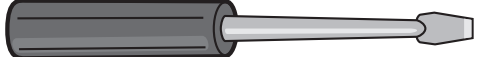
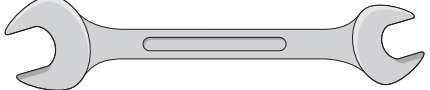
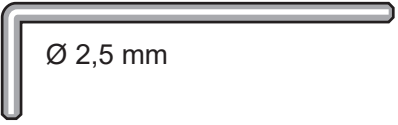
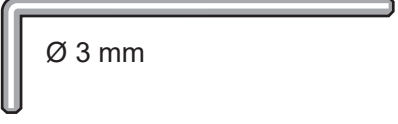
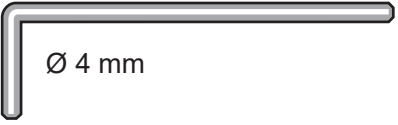
Werkzeuge / Tools*	
X	
X	
X	
X	
X	
X	
(X)	
X	
X	
	
X	

Werkzeuge / Tools*	
X	
X	
X	
X	 Ø 2,5 mm
X	 Ø 3 mm
X	 Ø 4 mm

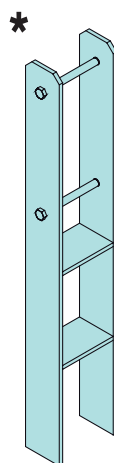
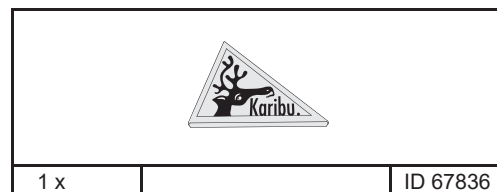
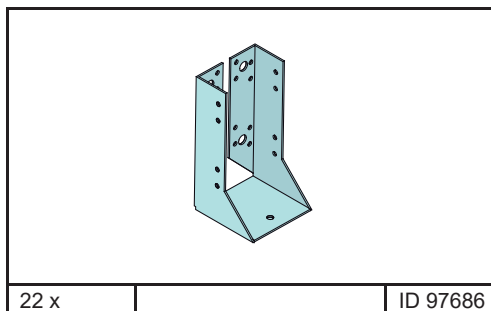
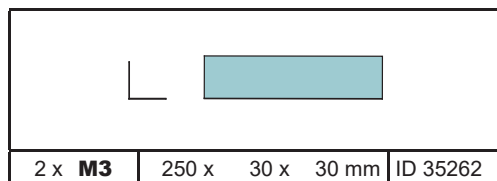
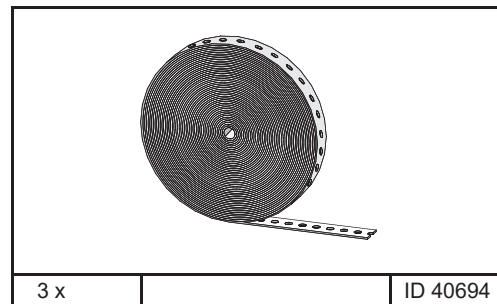
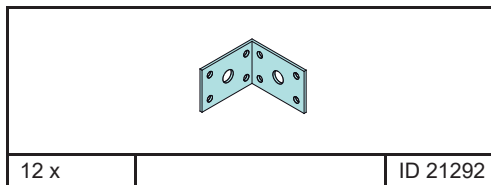
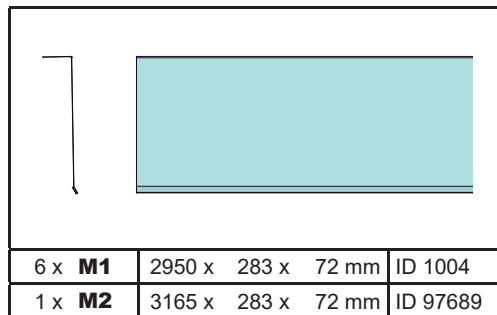





 Die Pfosten dieses Produkts sollten fest mit dem Untergrund verbunden werden. Dazu empfehlen wir H-Pfostenanker. Diese sollten erst nach dem Aufbau dieses Produkts endgültig mit Beton versehen werden. Die H-Pfostenanker und das zugehörige Befestigungsmaterial sind nicht im Lieferumfang dieses Produkts enthalten.

 The posts of this product should be firmly connected to the ground. We recommend H-post anchors. These should only be finally provided with concrete after the construction of this product. The H-post anchors and associated fasteners are not included with this product.

 Les poteaux de cet article doivent être fixés au sol. A cet effet, nous vous recommandons les systèmes d'ancrage en H (accessoires non fournis avec le produit). Ceux-ci doivent être scellés avec du béton une fois la construction du produit terminée.

 De berichten van dit product moet op de grond vastgemaakt. Wij bevelen ook het H-bericht ankers. Deze dienen echter pas na de uiteindelijke structuur van het product met beton worden. De H-paal ankers en de bijbehorende bevestigingsmaterialen worden niet meegeleverd met dit product.

 Los mensajes de este producto debe fijarse al suelo. También te recomendamos anclas H-post. Estos deben ser proporcionados sólo después de la estructura final del producto de hormigón. Los anclajes H-correos y los materiales de fijación asociados no están incluidos con este producto.

 I messaggi di questo prodotto devono essere fissati al suolo. Noi raccomandiamo anche ancore H-post. Questi dovrebbero essere forniti solo dopo che la struttura finale del prodotto con calcestruzzo. Le ancore H-post ed i materiali di fissaggio associati non sono inclusi con questo prodotto.

 Stolperne på dette produkt skal være solidt forbundet med jorden. Vi anbefaler H-stolpeankre til dette formål. Disse skal først fyldes med beton, når produktet er blevet samlet. H-stolpeankrene og de tilhørende fastgørelsesmaterialer er ikke inkluderet i dette produkt.

 Sloupky tohoto produktu by měla být stanovena na zem. Doporučujeme také H-post kotvy. Ty by měly být poskytnuty pouze po konečnou strukturu výrobku s betonem. H-post kotvy a příslušné upevňovací materiály nejsou součástí tohoto produktu.

 Stebri tega izdelka morajo biti trdno povezani z zemljo. V ta namen priporočamo sidra v obliki stebra H. Te je treba dokončno zapolniti z betonem šele po montaži tega izdelka. Sidro za stebričke H in pripadajoči pritrdilni material nista priložena temu izdelku.



 Informieren Sie sich, vor der Montage Ihres Produktes, ob eine **Baugenehmigung** einer Baubehörde erforderlich ist! Prüfen Sie, ob sich im Fundamentbereich evtl. Elektro- und Wasseranschlüsse/-leitungen befinden.

Die Dachlast gesamt beträgt 155kg/m²

Wird ein Gründach mit 70kg/m² aufgebracht, reduziert sich die Schneelast auf 85kg/m²

Windzone 2

 Before installing your product, find out whether a **building licence** from a building authority is required! Check whether there are any electrical and water connections/pipes in the foundation area.

Die Dachlast gesamt beträgt 155kg/m²

The total roof load is 155kg/m²

If a green roof with 70kg/m² is applied, the snow load is reduced to 85kg/m²

Wind zone 2

 Avant de monter votre produit, renseignez-vous sur la nécessité d'obtenir un **permis de construire** auprès d'une autorité de construction! Vérifiez si d'éventuels raccordements/conduites électriques et d'eau se trouvent dans la zone des fondations.

La charge totale du toit est de 155kg/m².

Si un toit vert de 70kg/m² est appliqué, la charge de neige est réduite à 85kg/m².

Zone de vent 2

 Voordat je je product installeert, moet je nagaan of een **bouwvergunning** van een bouwinstantie vereist is! Controleer of er elektrische en wateraansluitingen/buizen zijn in het funderingsgebied.

De totale dakbelasting is 155kg/m²

Als een groendak met 70kg/m² wordt toegepast, wordt de sneeuwbelasting verlaagd tot 85kg/m²

Windzone 2

 Antes de instalar el producto, infórmate de si es necesario obtener un **permiso de obras** de la autoridad competente. Compruebe si hay conexiones/tuberías eléctricas y de agua en la zona de los cimientos.

La carga total de la cubierta es de 155 kg/m².

Si se aplica un tejado verde de 70kg/m², la carga de nieve se reduce a 85kg/m².

Zona de viento 2

 Prima di installare il vostro prodotto, informatevi se è necessario un **permesso di costruzione** da parte dell'autorità edilizia! Verificare la presenza di collegamenti elettrici e idrici e di tubature nell'area di fondazione.

Il carico totale del tetto è di 155 kg/m²

Se si applica un tetto verde di 70 kg/m², il carico di neve si riduce a 85 kg/m².

Zona di vento 2

 Før du installerer dit produkt, skal du finde ud af, om der kræves en **byggetilladelse** fra en bygningsmyndighed! Tjek, om der er el- og vandtilslutninger/rør i fundamentområdet.

Den samlede tagbelastning er 155 kg/m².

Hvis der anvendes et grønt tag med 70 kg/m², reduceres snebelastningen til 85 kg/m².

Vindzone 2

 Před instalací výrobku si zjistěte, zda je nutné **stavební povolení** od stavebního úřadu! Zkontrolujte, zda se v oblasti základů nenachází elektrické a vodovodní přípojky/potrubí.

Celkové zatížení střechy je 155 kg/m²

Pokud se použije zelená střecha o hmotnosti 70 kg/m², sníží se zatížení sněhem na 85 kg/m².

Větrná zóna 2

 Pred namestitvijo izdelka se pozanimajte, ali je potrebno **gradbeno dovoljenje** gradbenega urada! Preverite, ali so na območju temeljev električni in vodovodni priključki/vodovodi.

Skupna obremenitev strehe je 155 kg/m²

Če se uporabi zelena streha s 70 kg/m², se obremenitev s snegom zmanjša na 85 kg/m²

Vetrovno območje 2

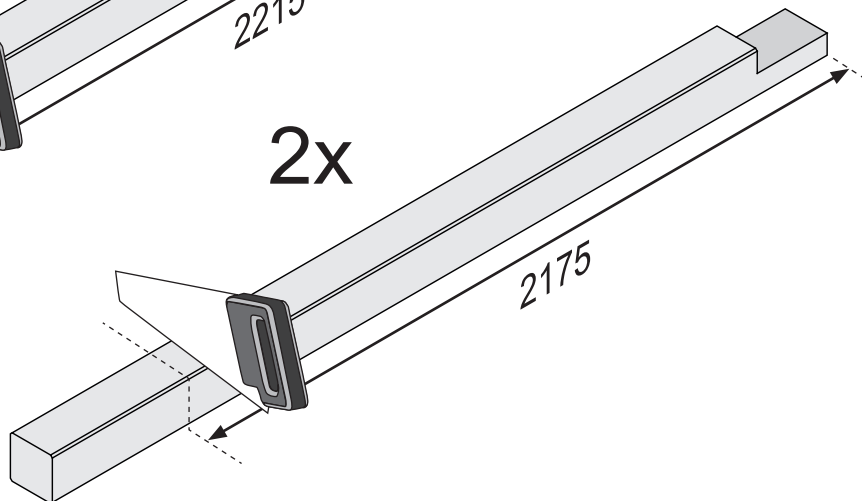
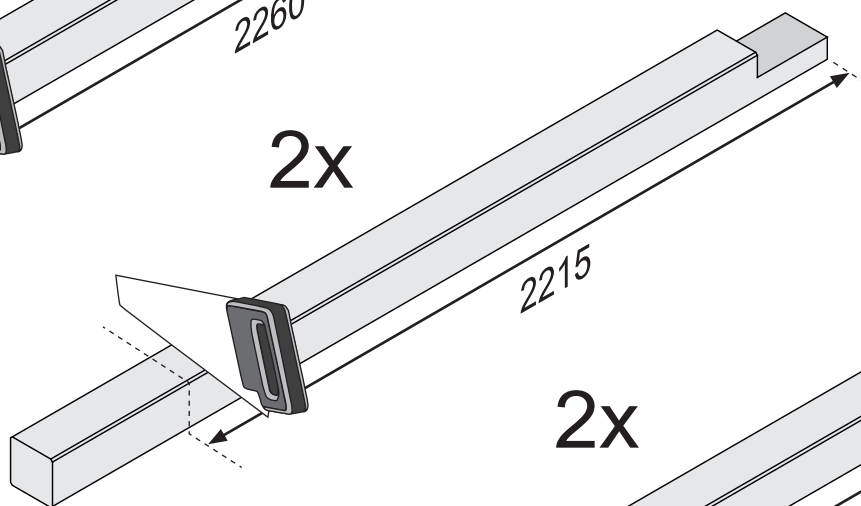
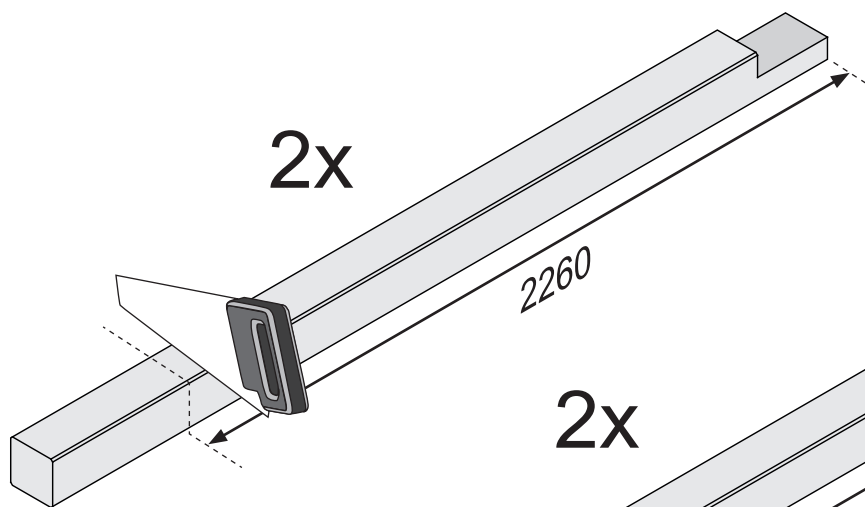
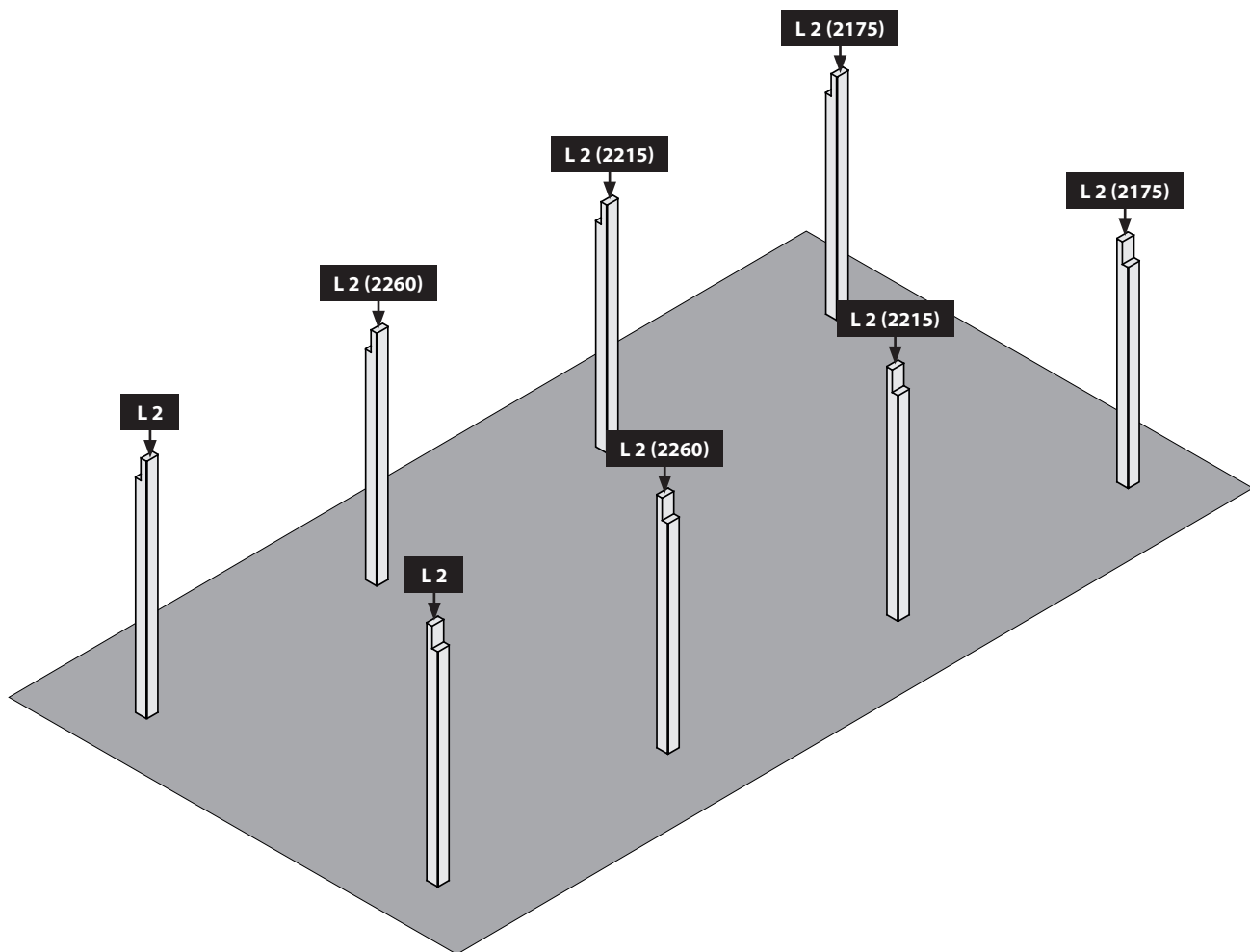

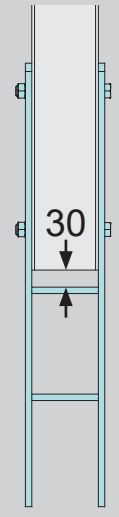
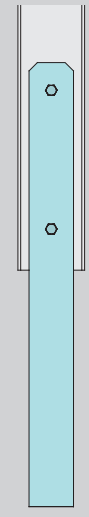
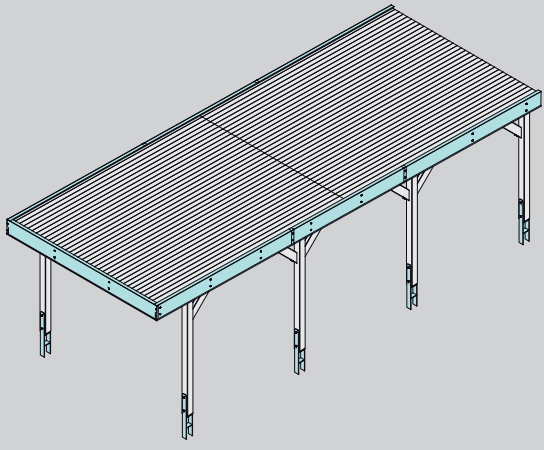
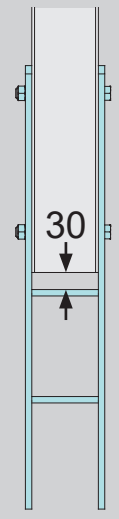
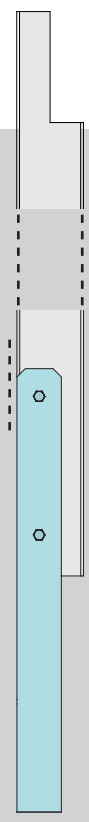
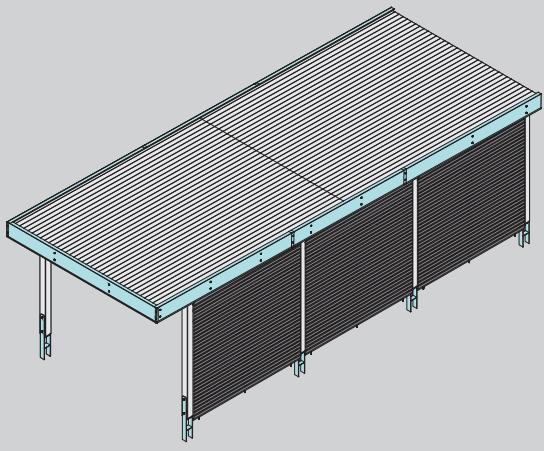
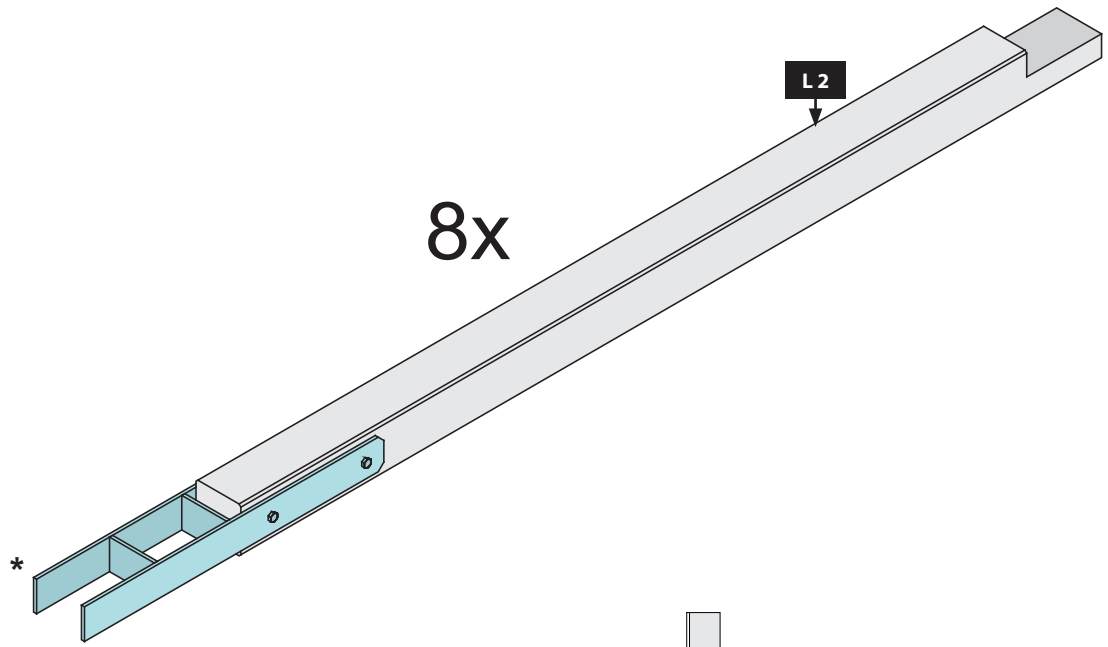

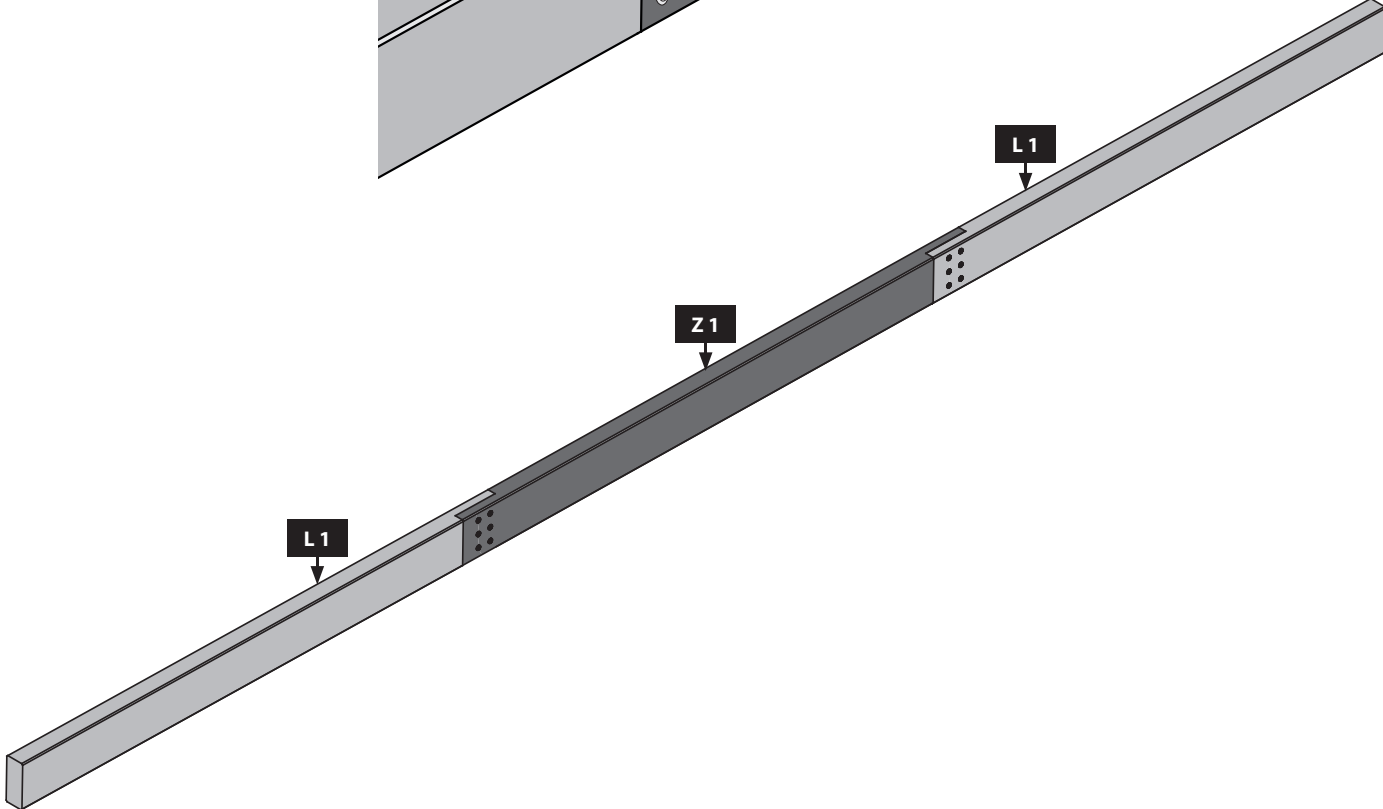
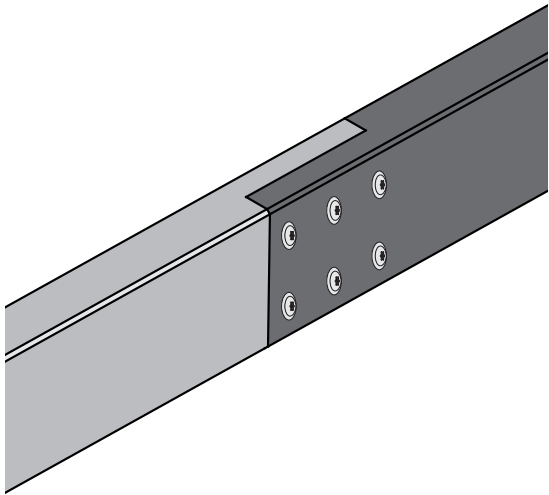
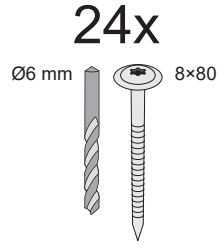
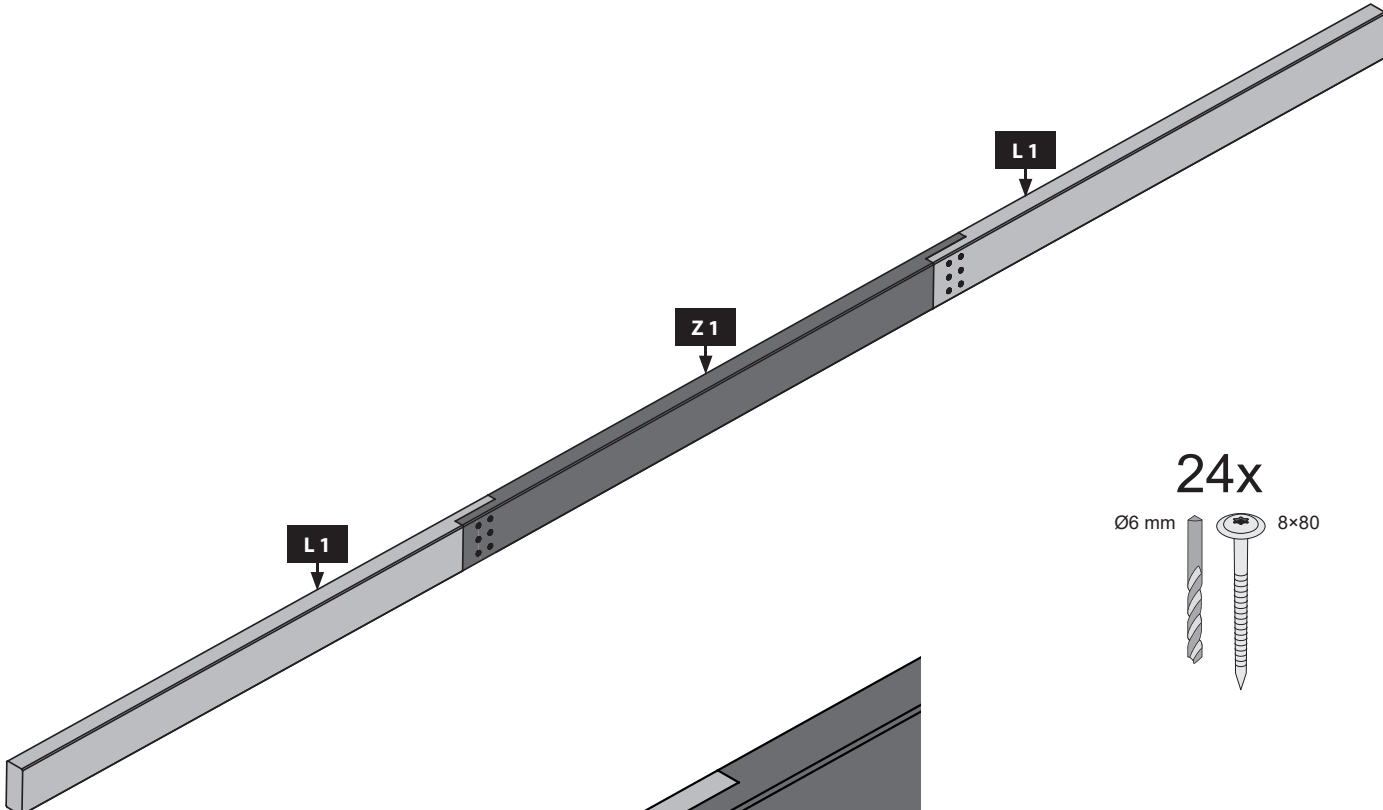

24x

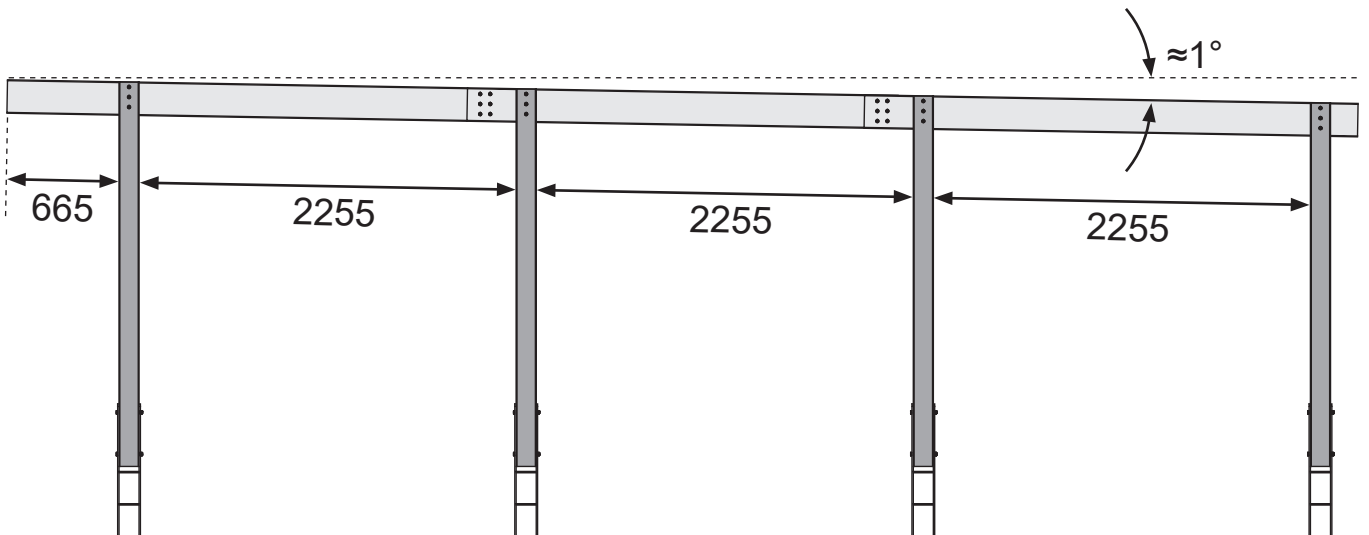
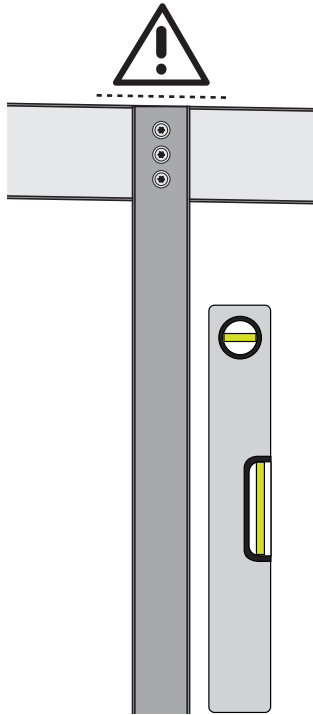
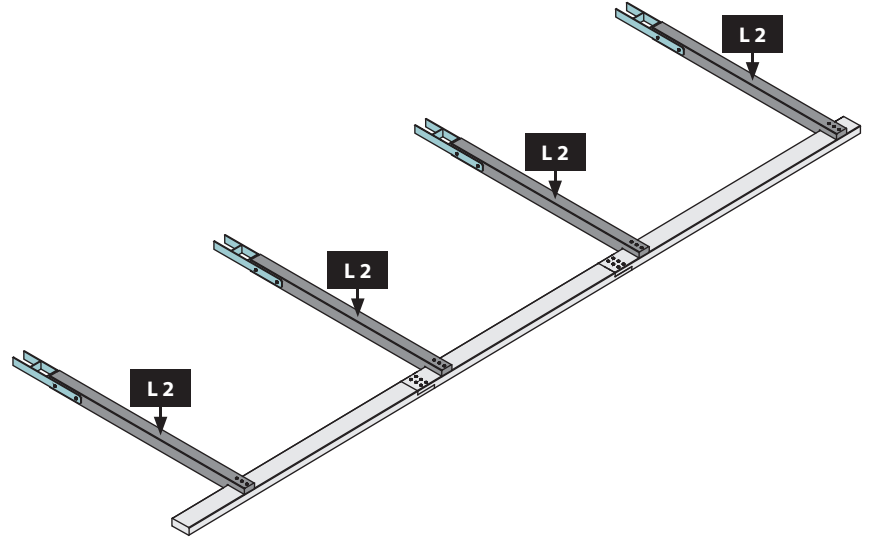
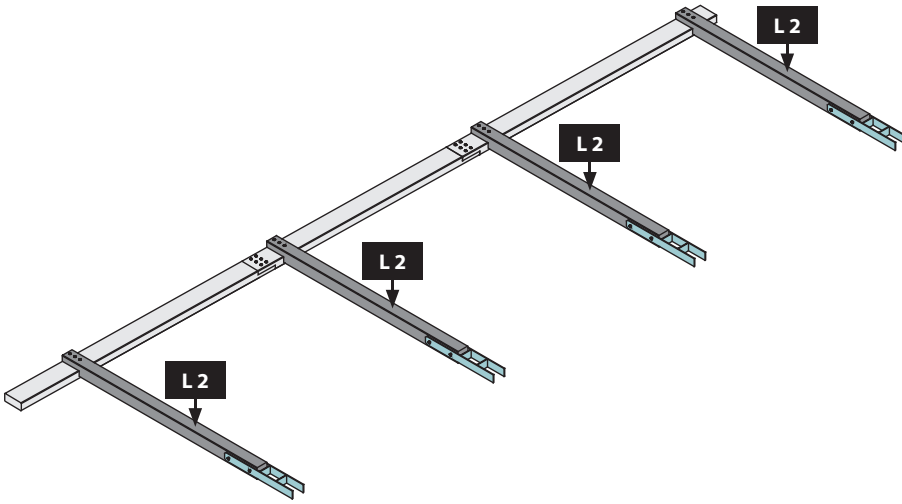
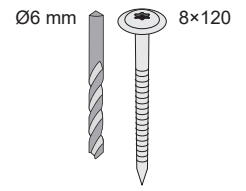

22x

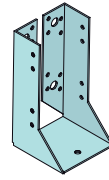

352x

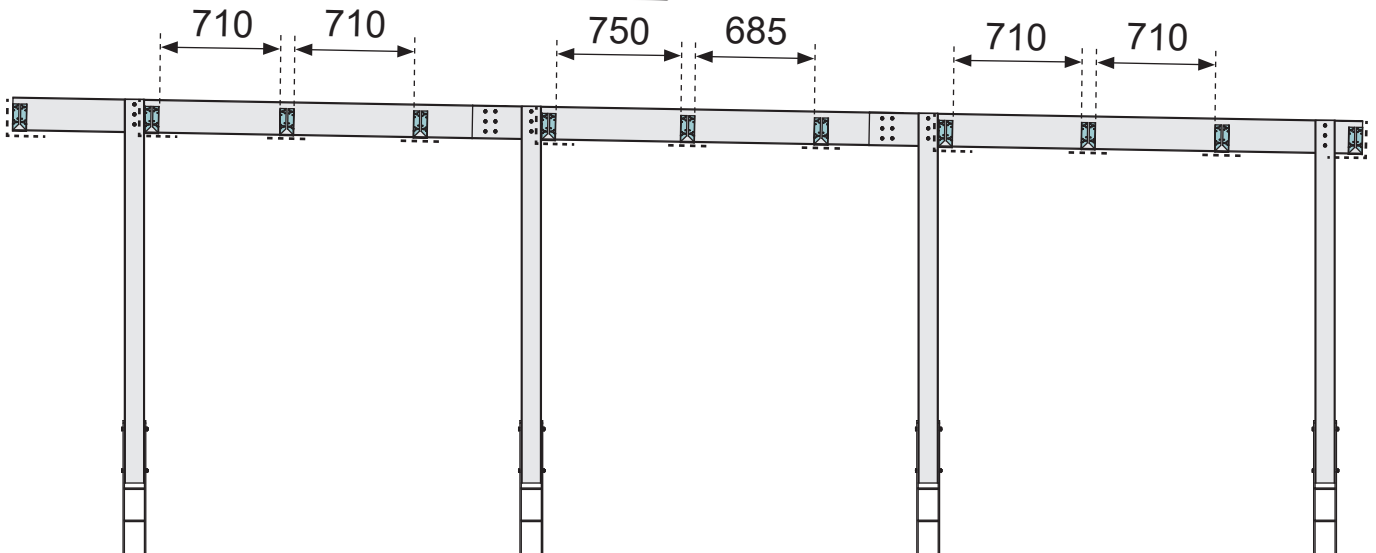
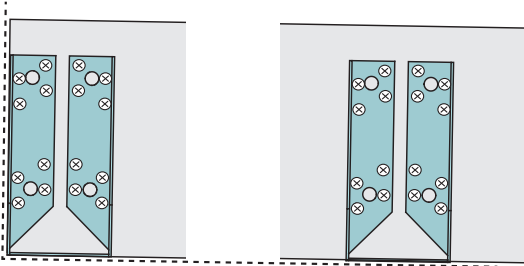
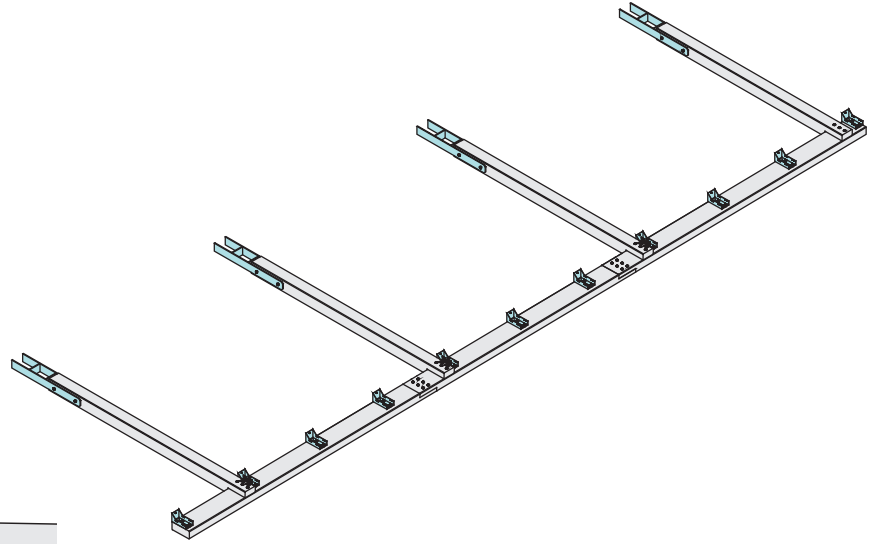
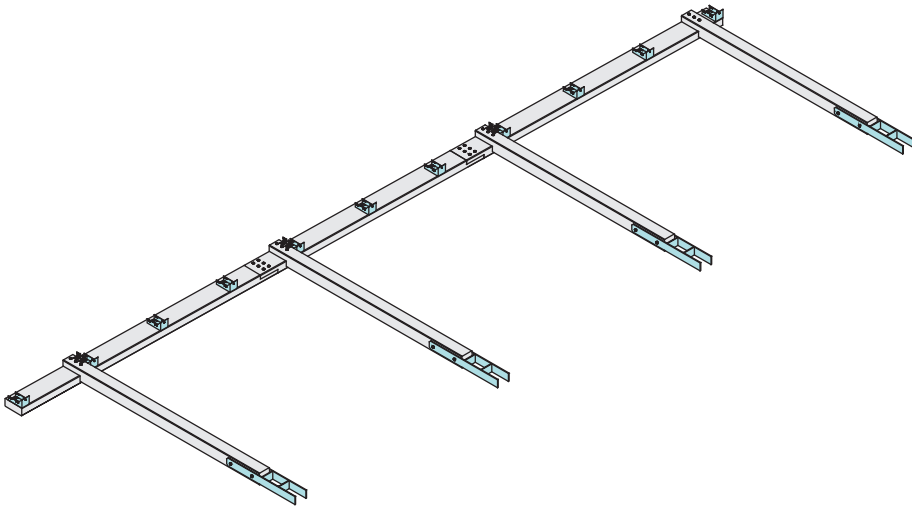
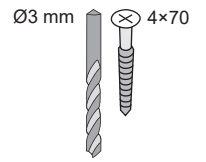

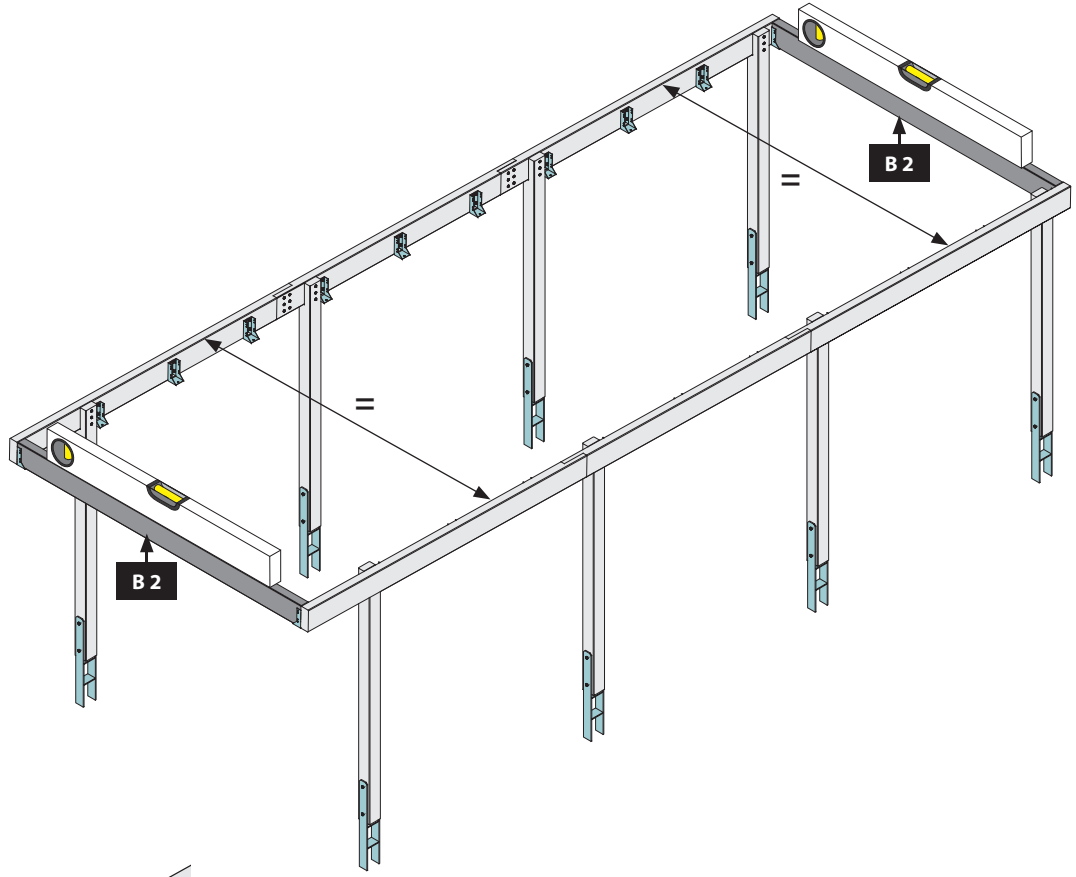

36x
Ø3 mm 4x70

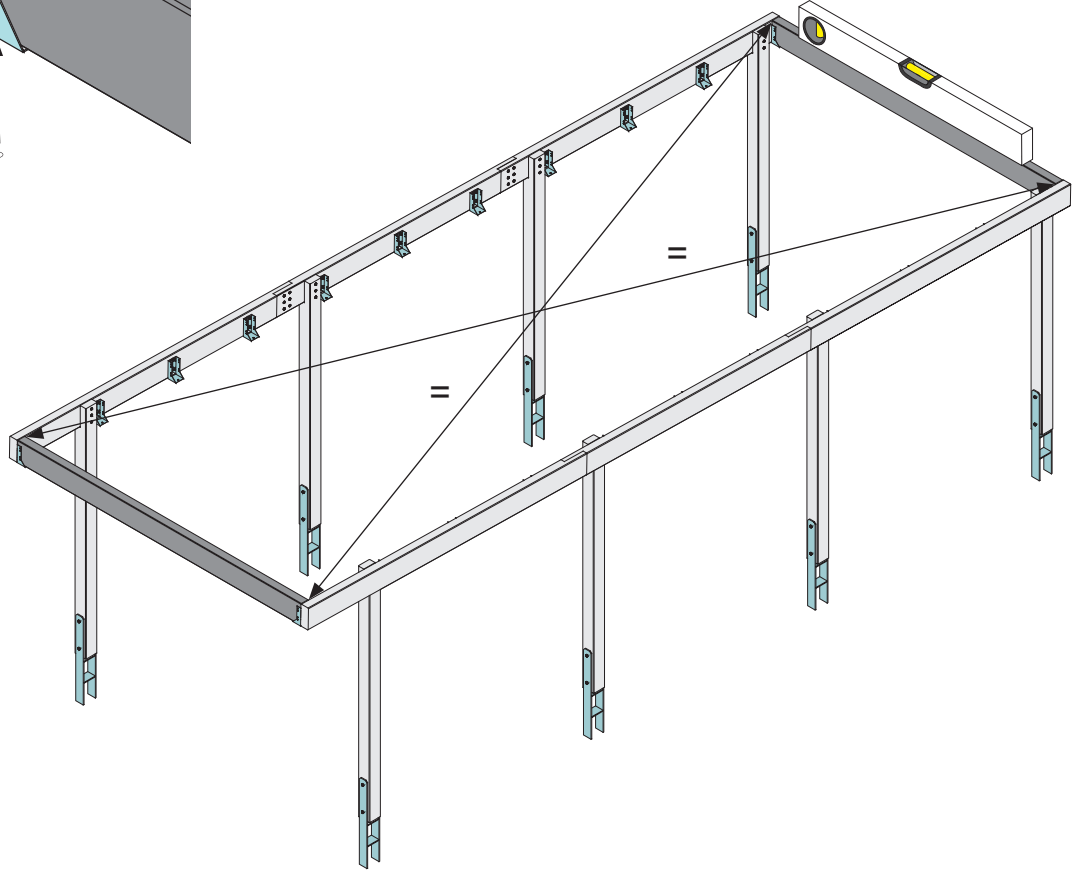
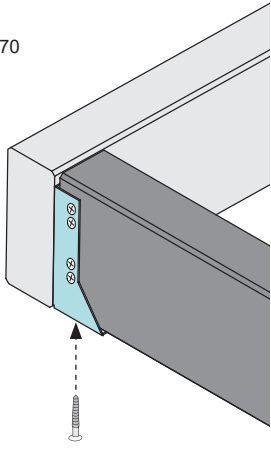

12x

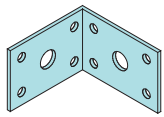

96x

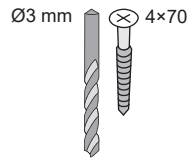

30x

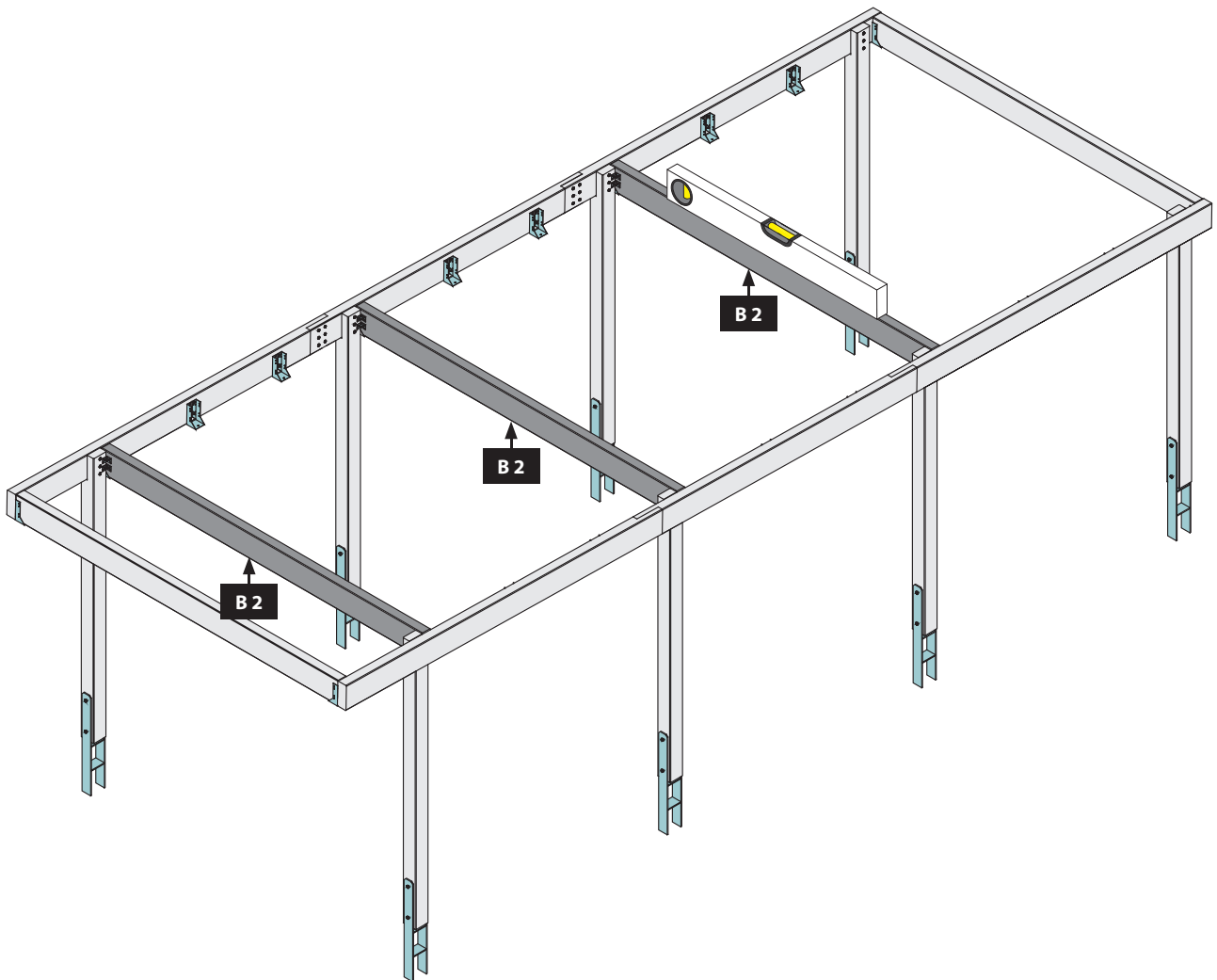
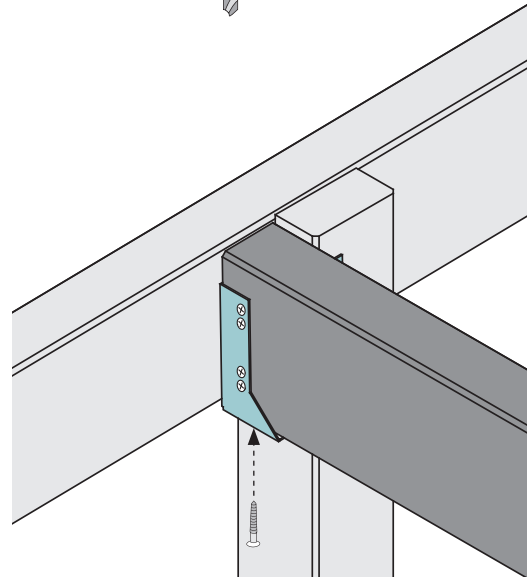
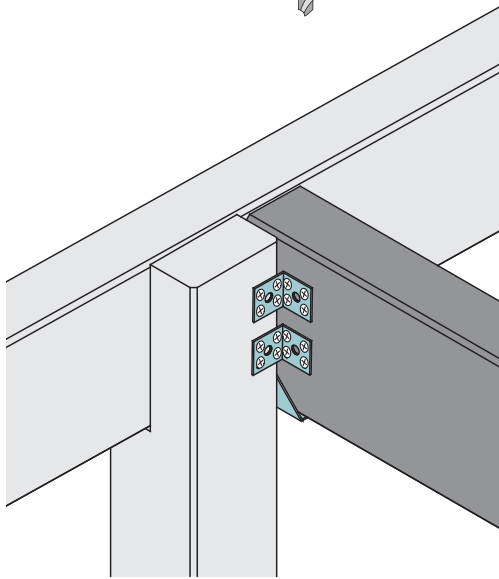
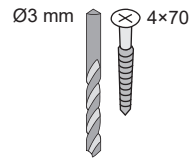

108x

Ø3 mm 4x70

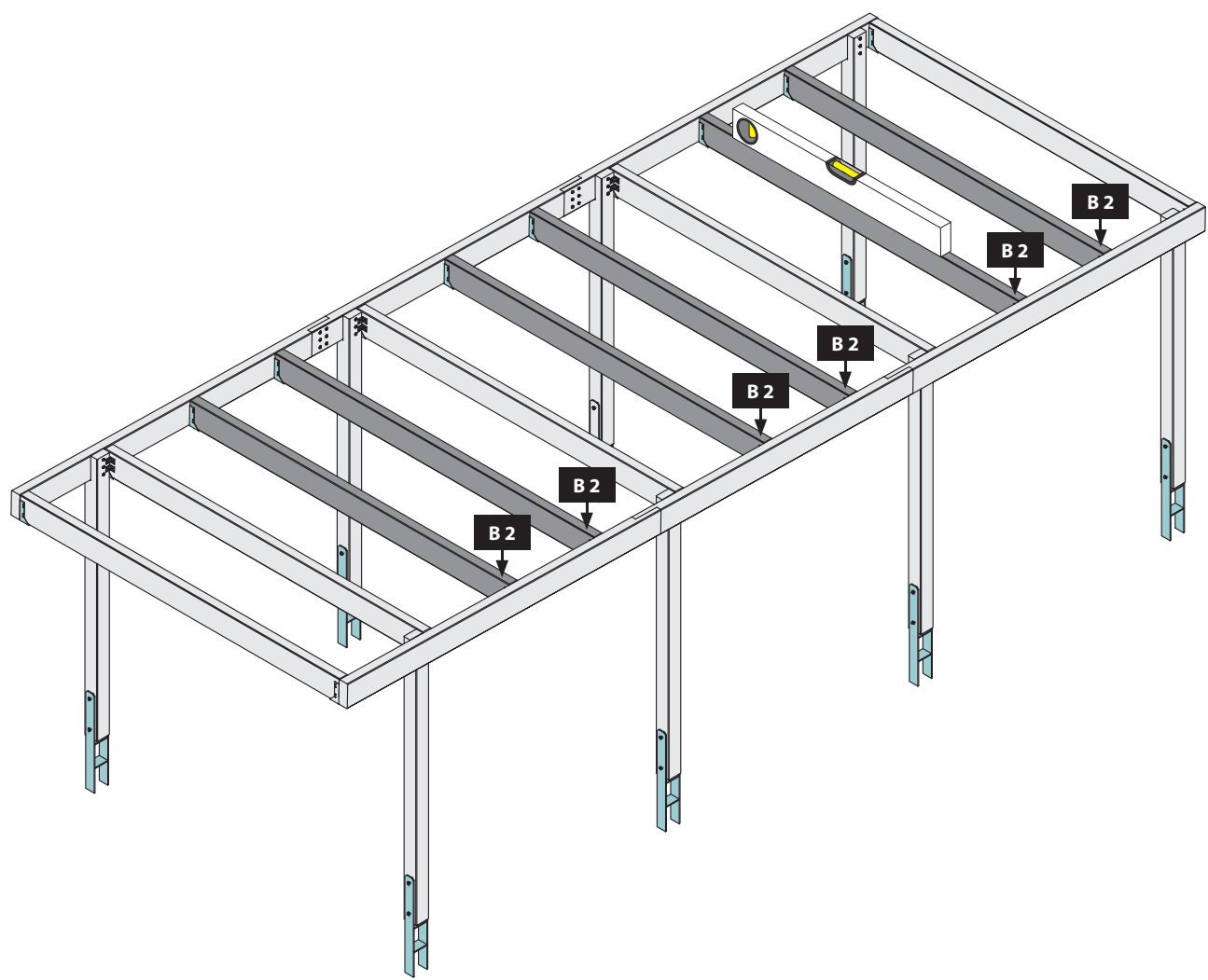
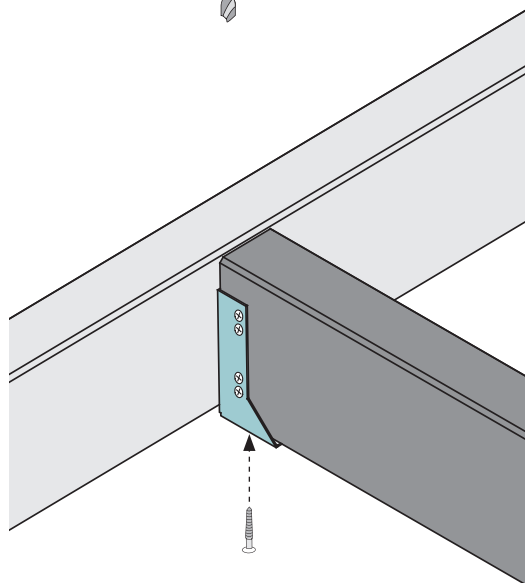
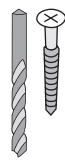

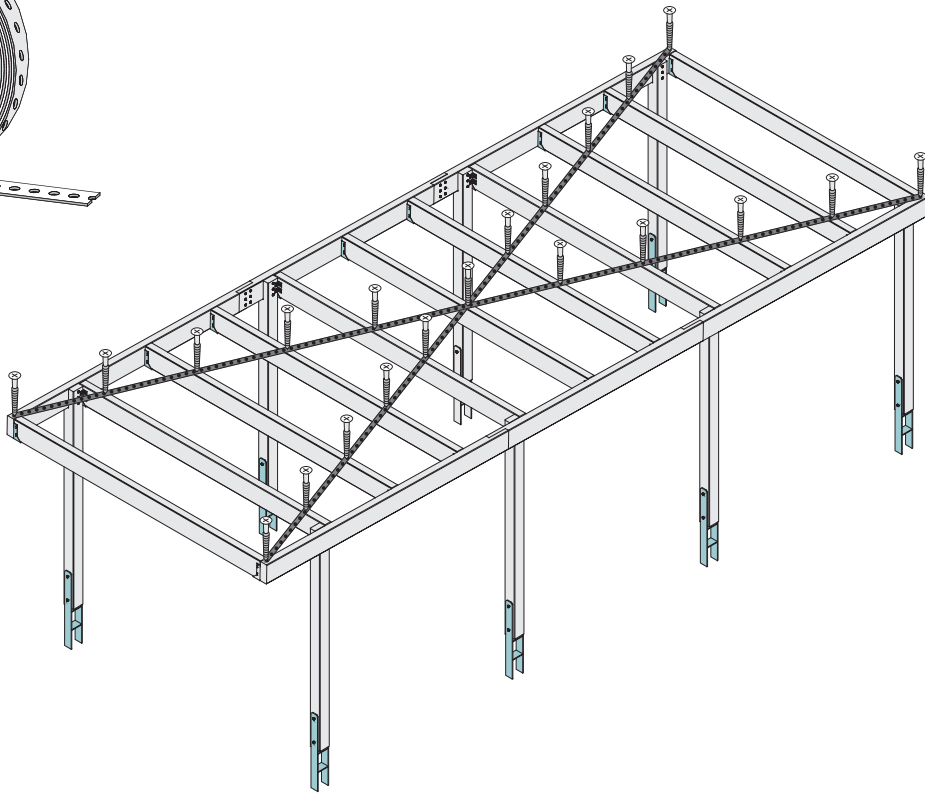
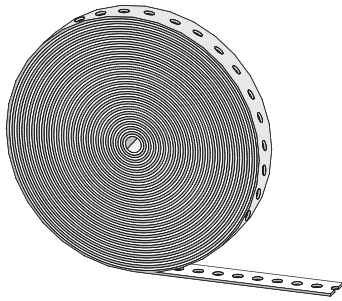

21x

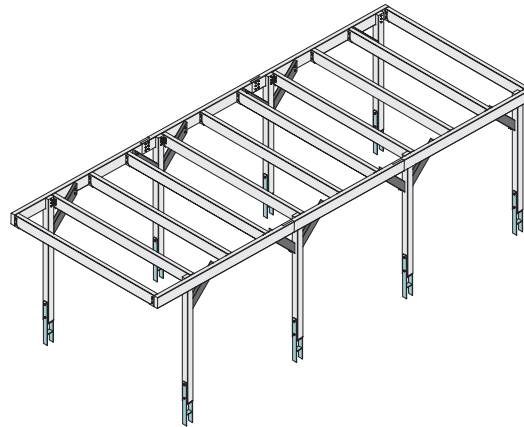
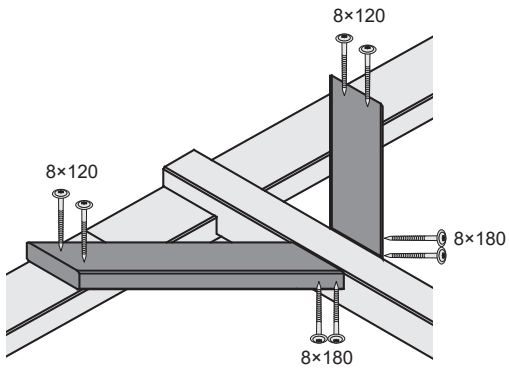
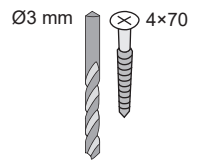

24x

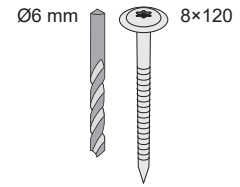



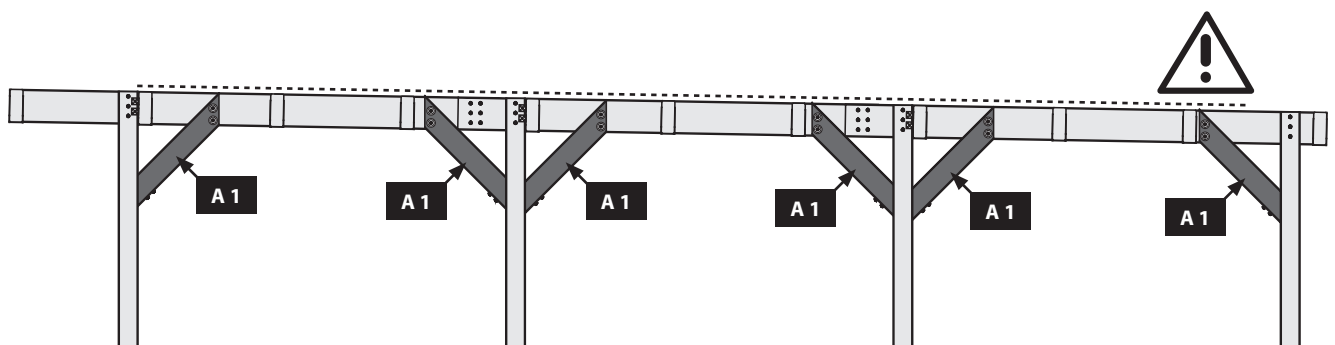
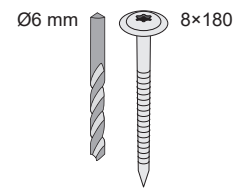

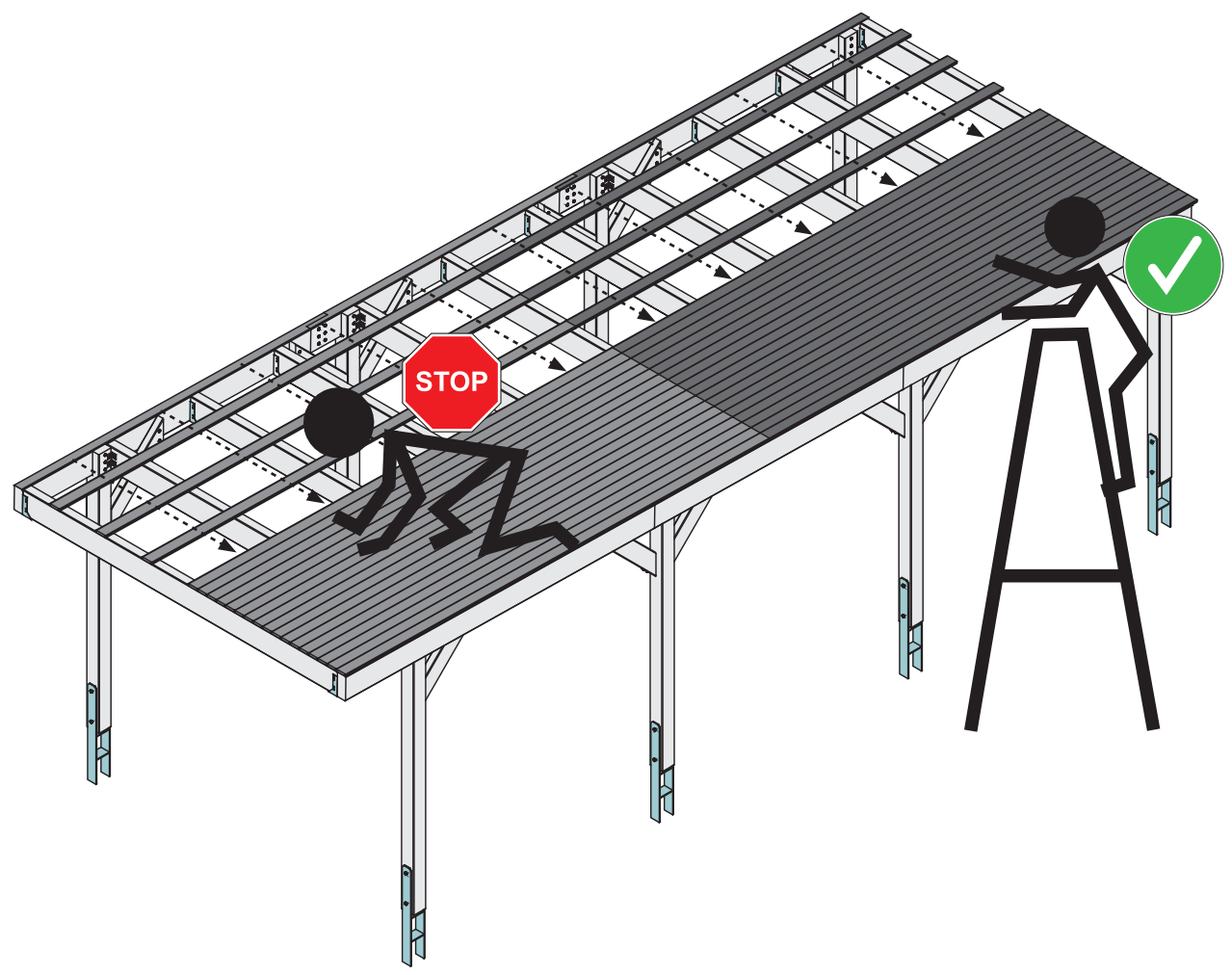
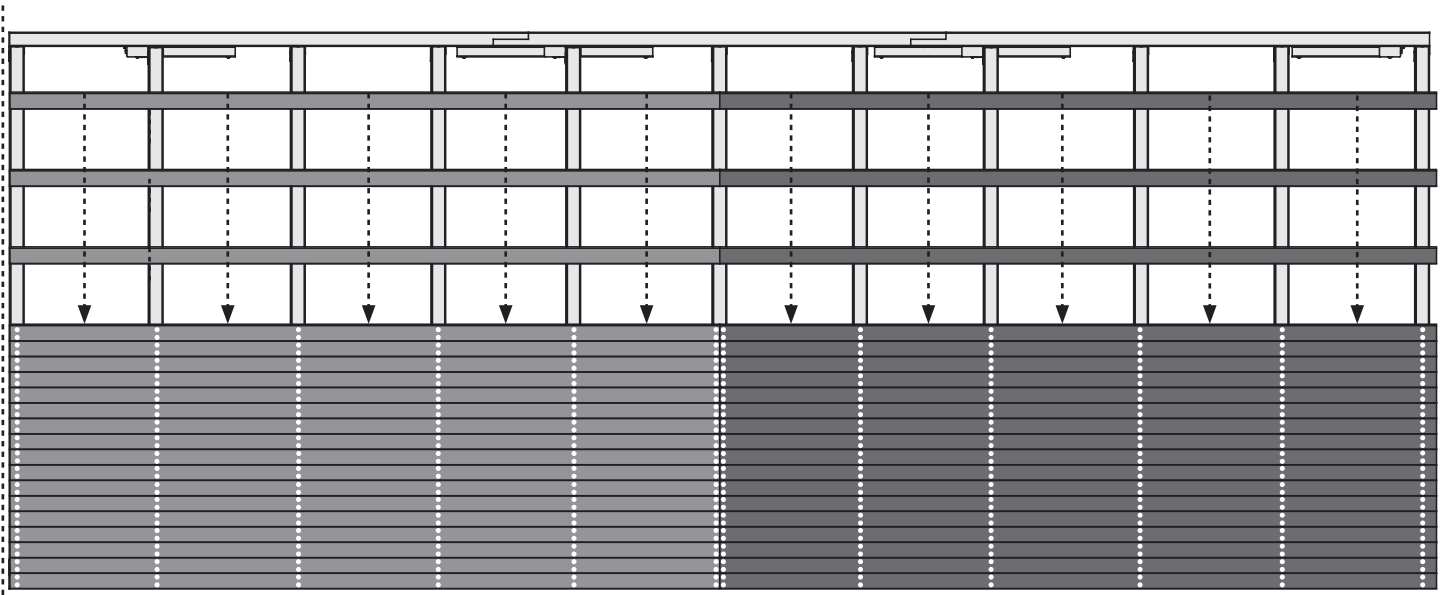
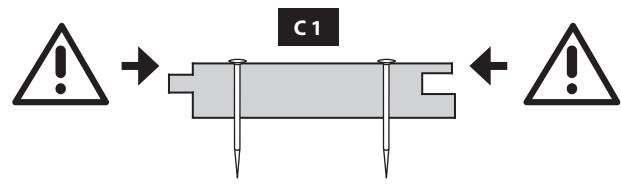
24x

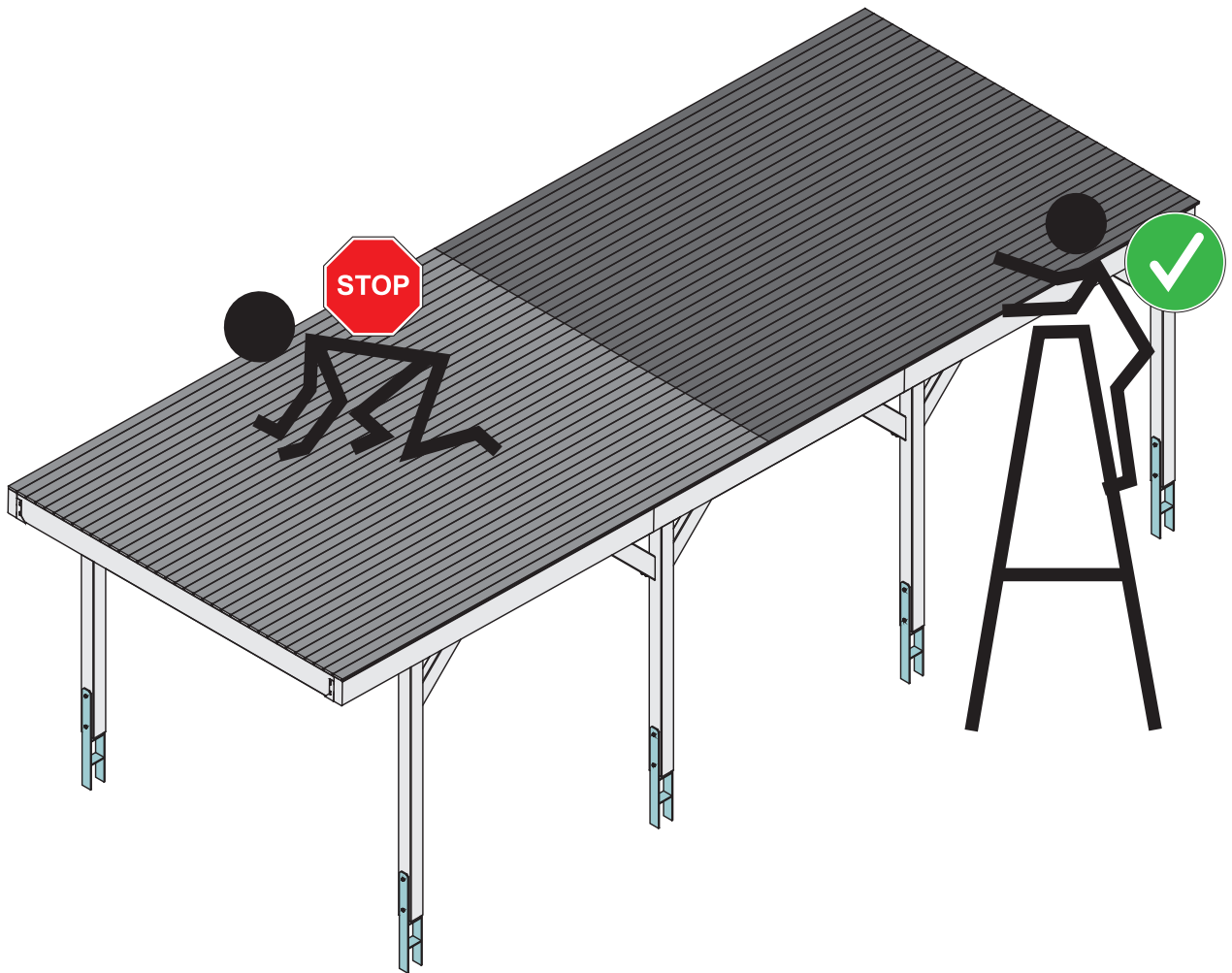
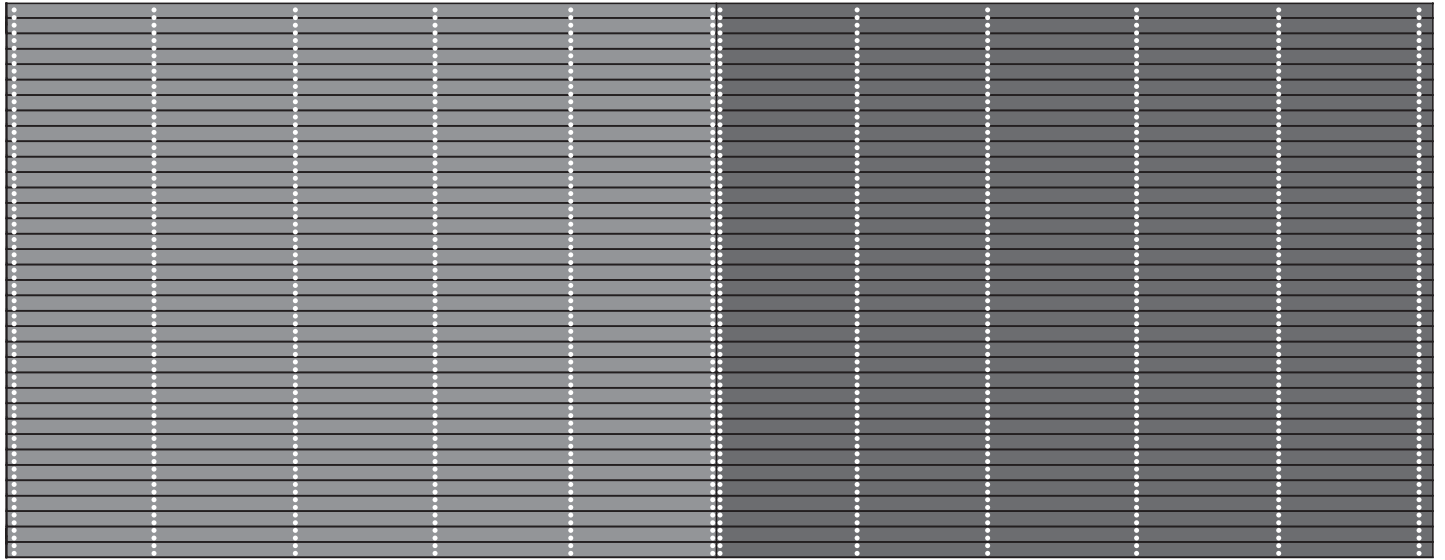
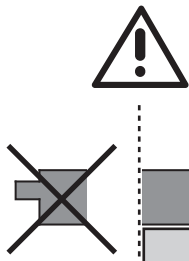
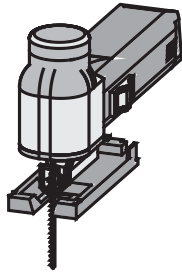

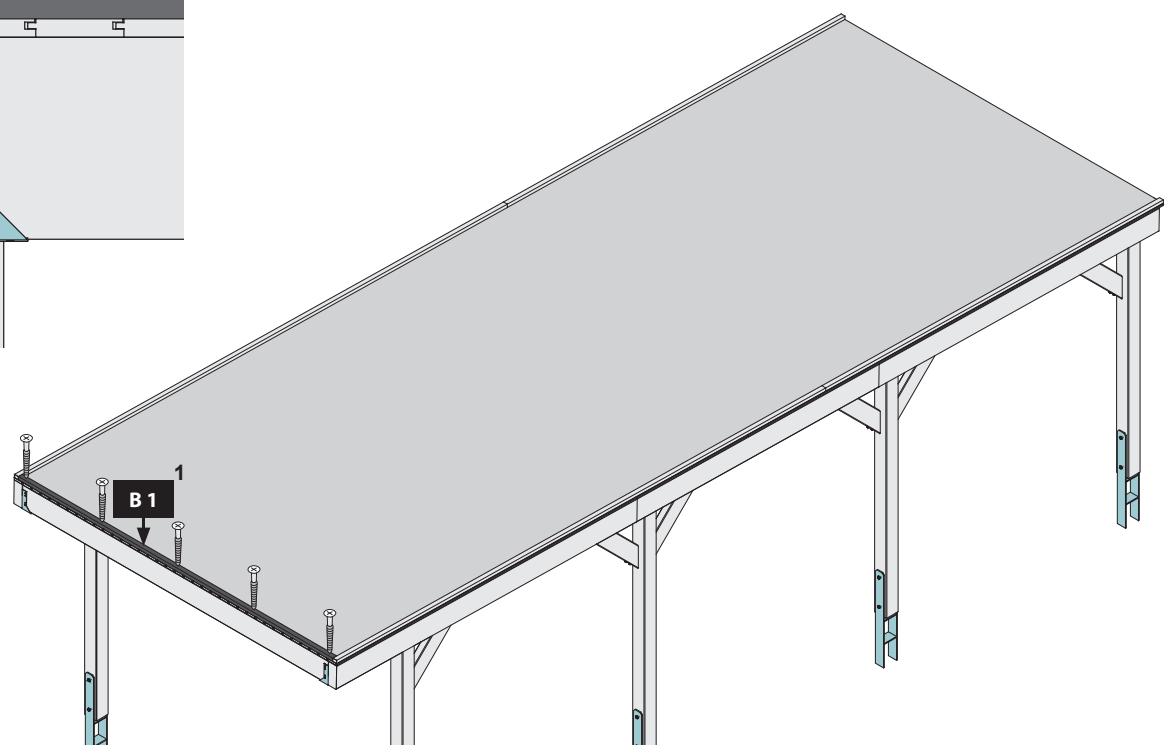
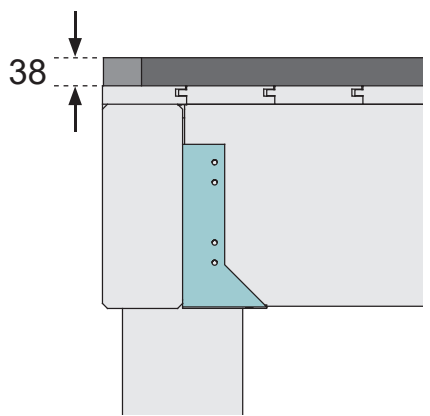
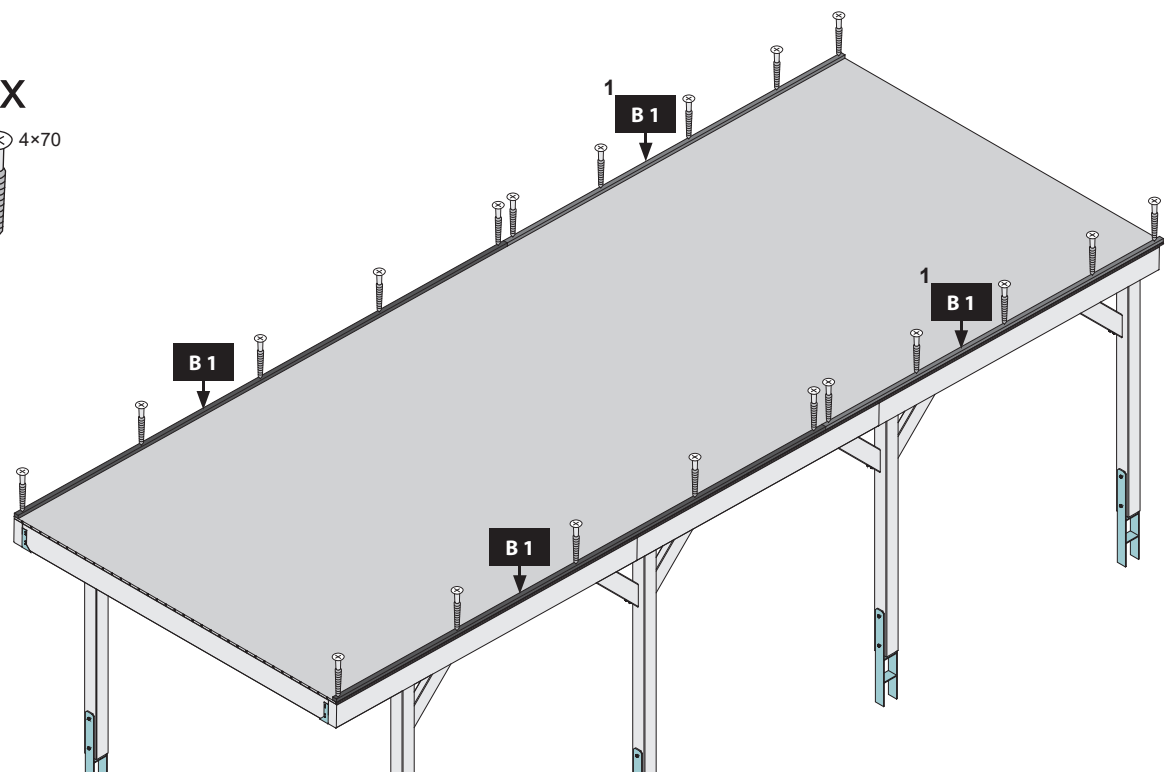
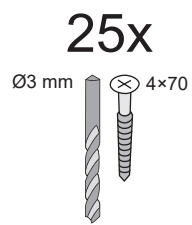
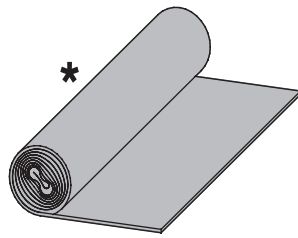











 Schutzfolie abziehen
 Remove protective film
 Retirer le film protecteur

 Verwijder de beschermende film
 Fjern beskyttelsesfilm
 Retire la película protector

 Rimuovere la pellicola protettiv
 Odstraňte ochranný film
 Odstranite zaščitno folijo

01

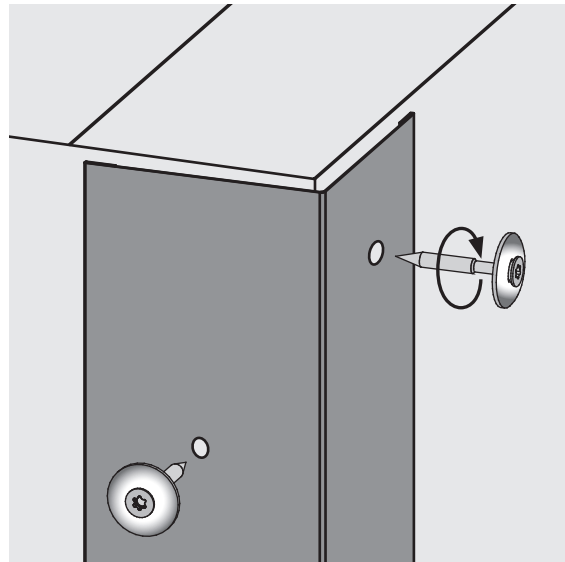

02

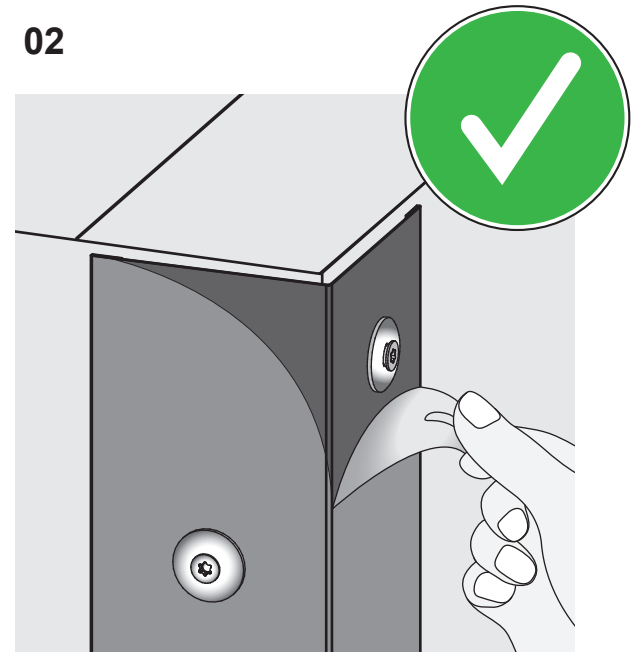

01

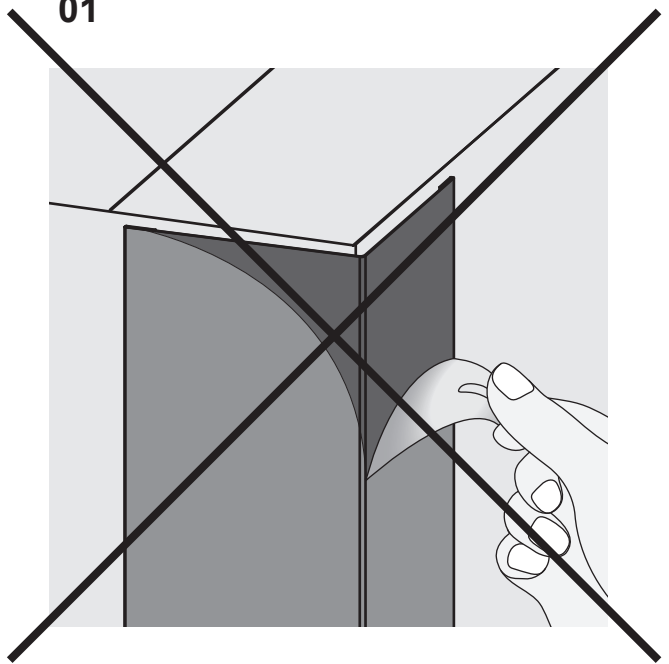

02

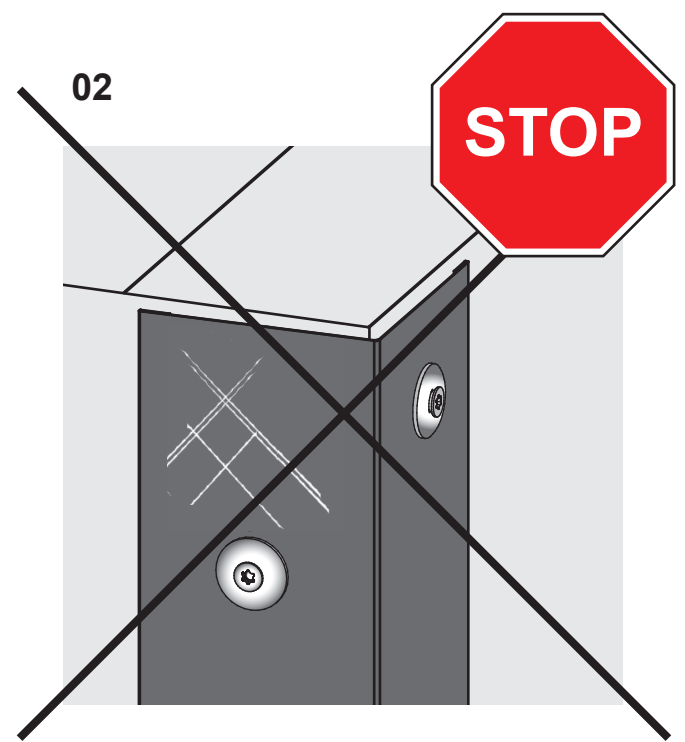

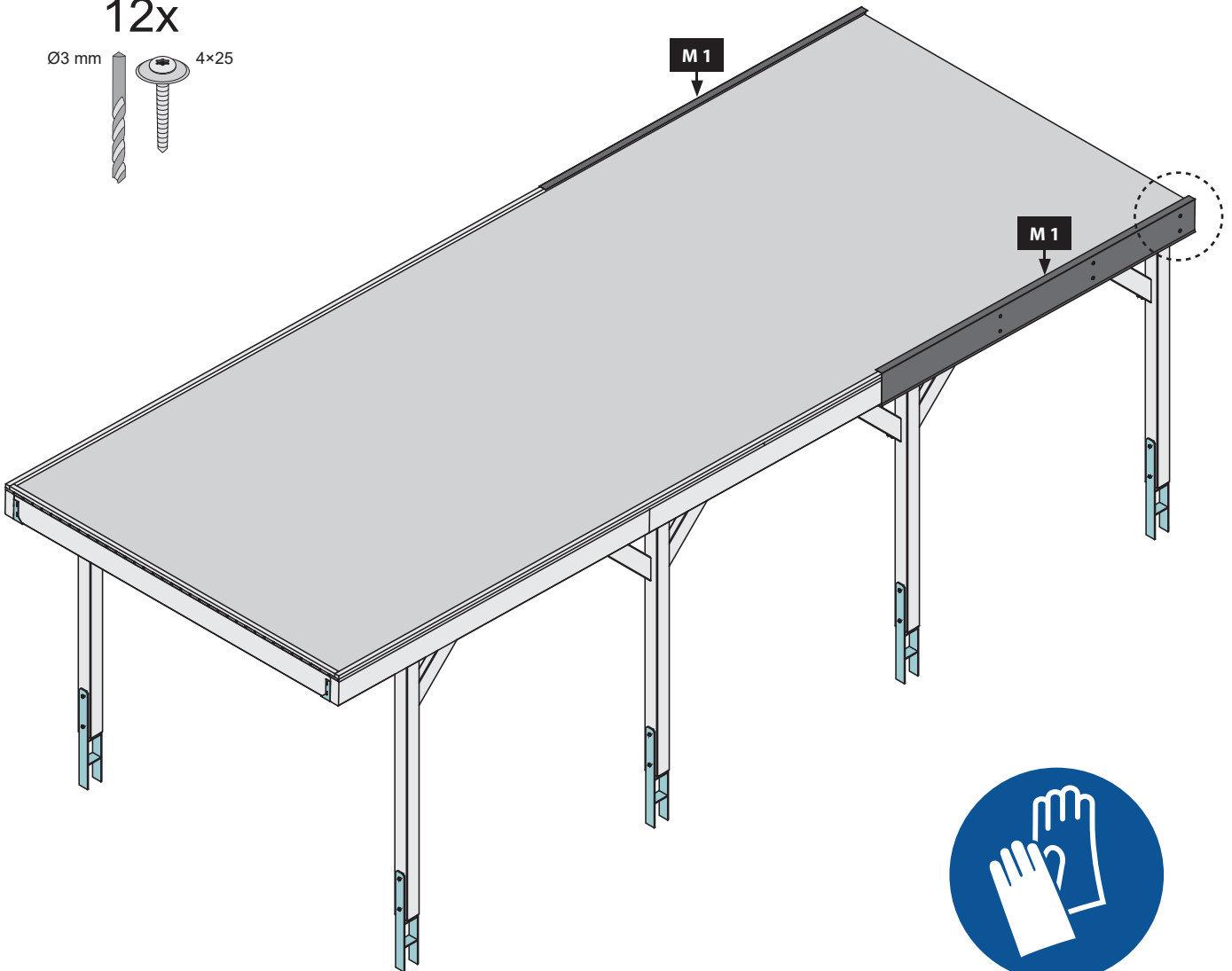
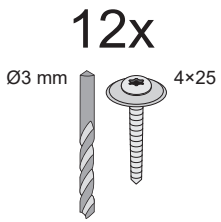
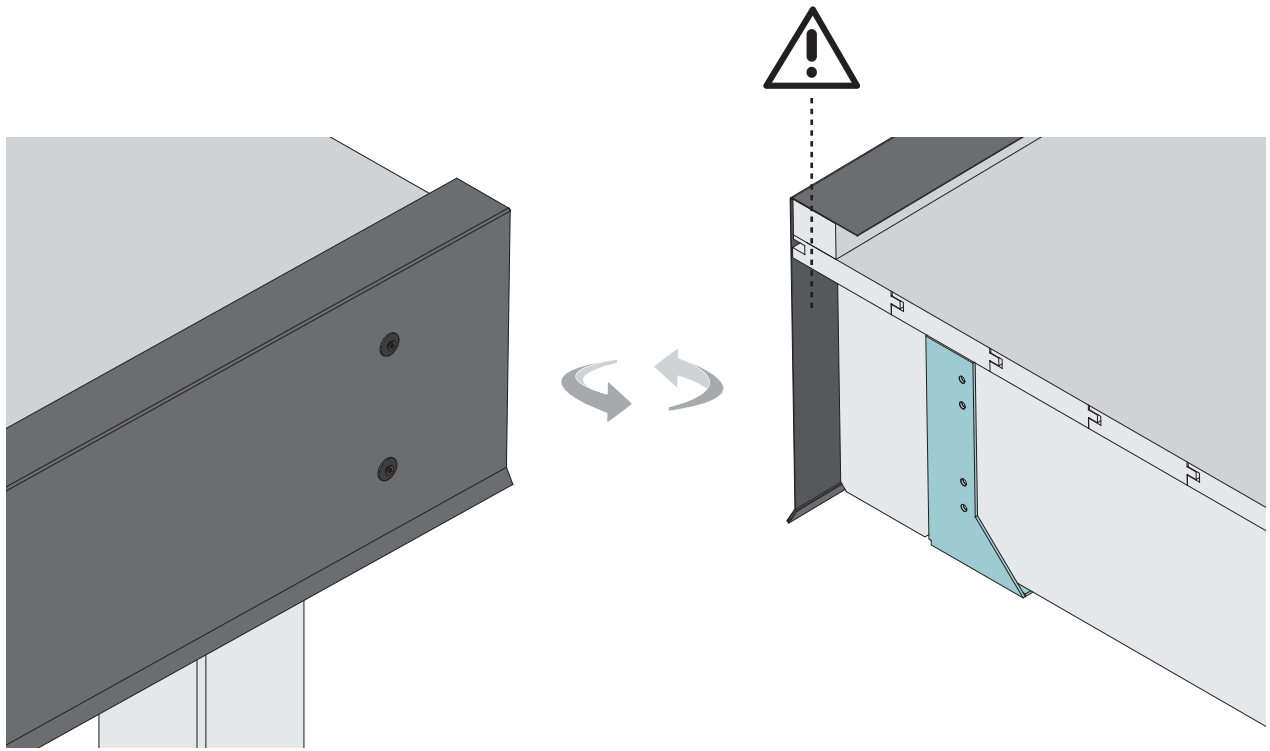

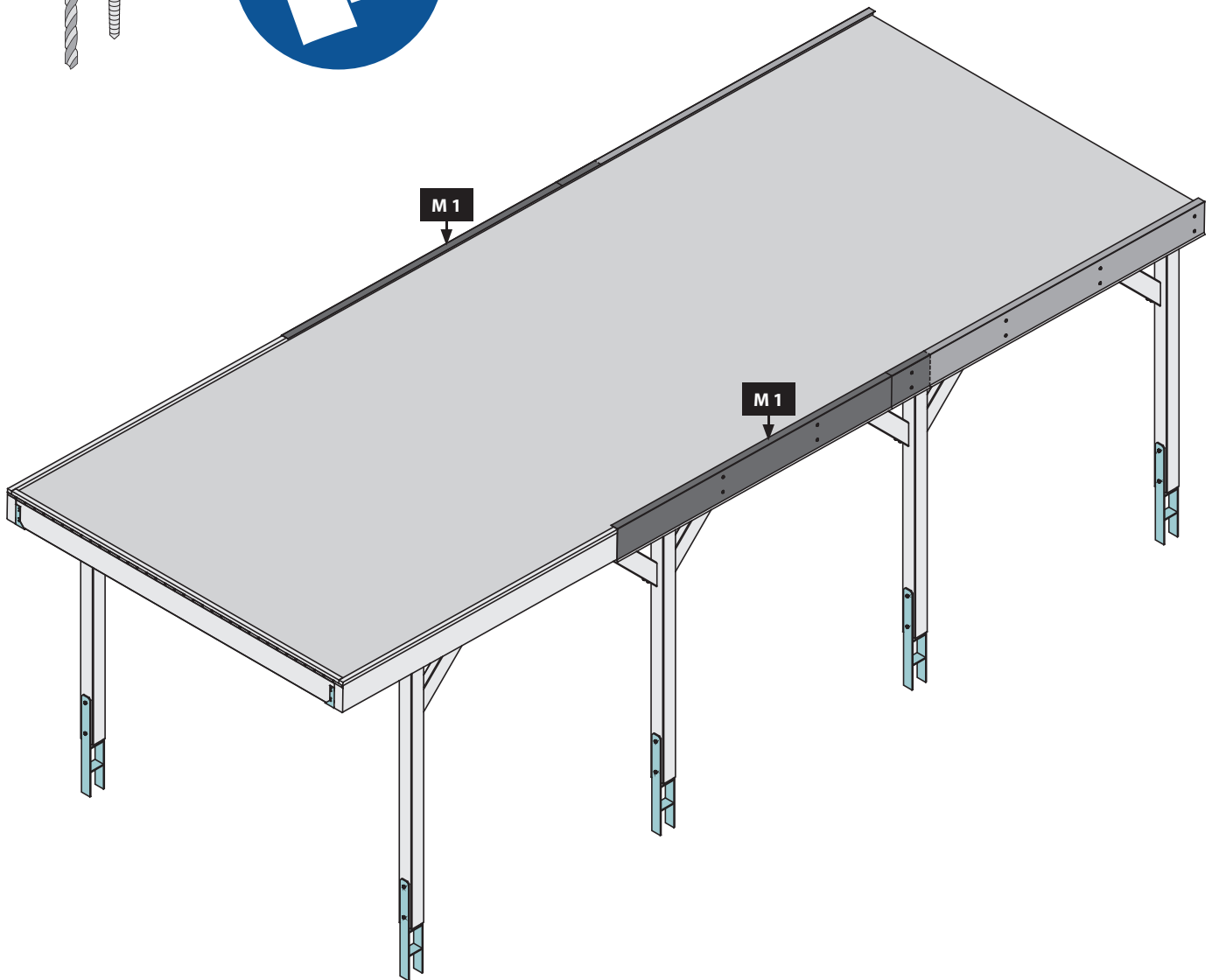
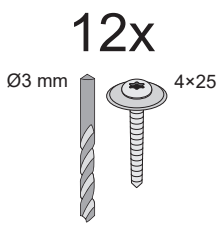
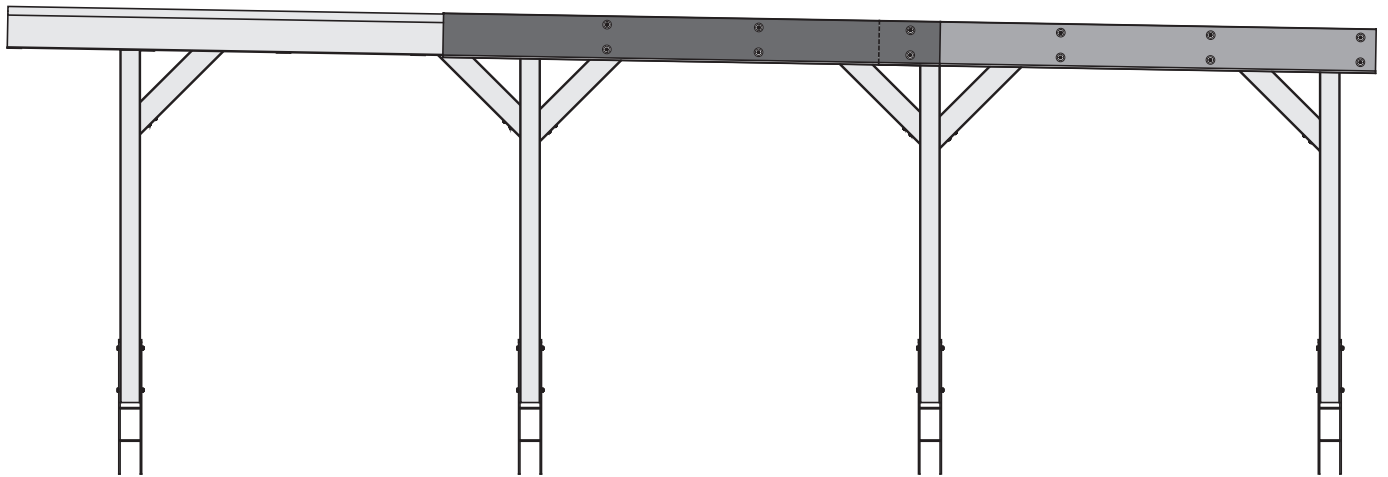

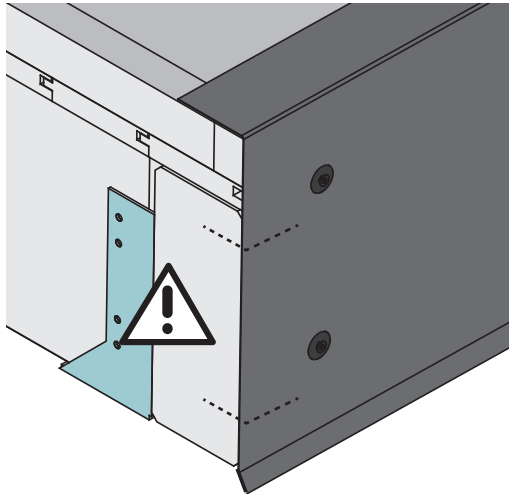



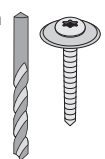
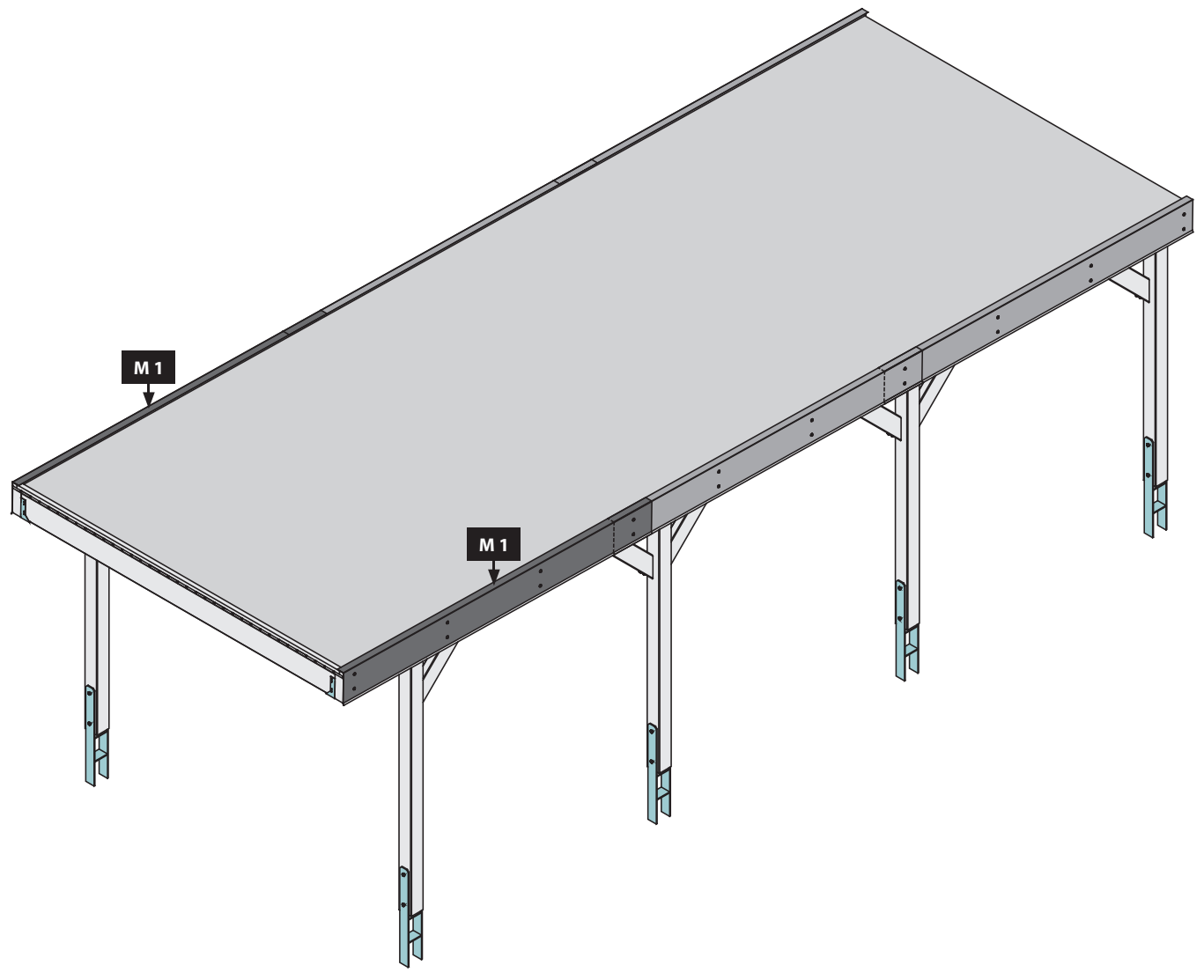

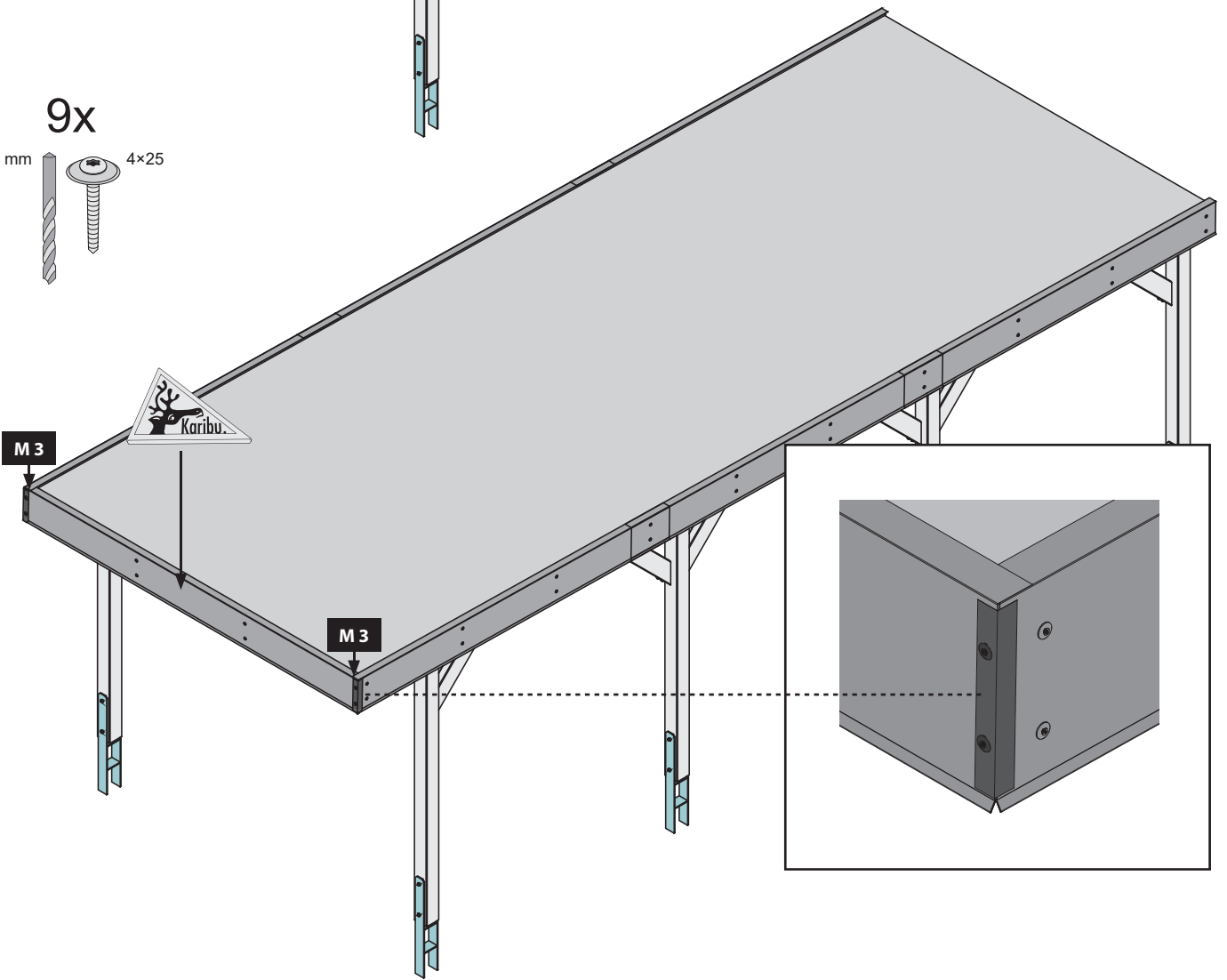
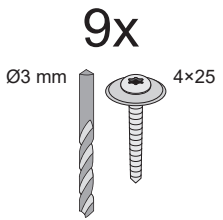
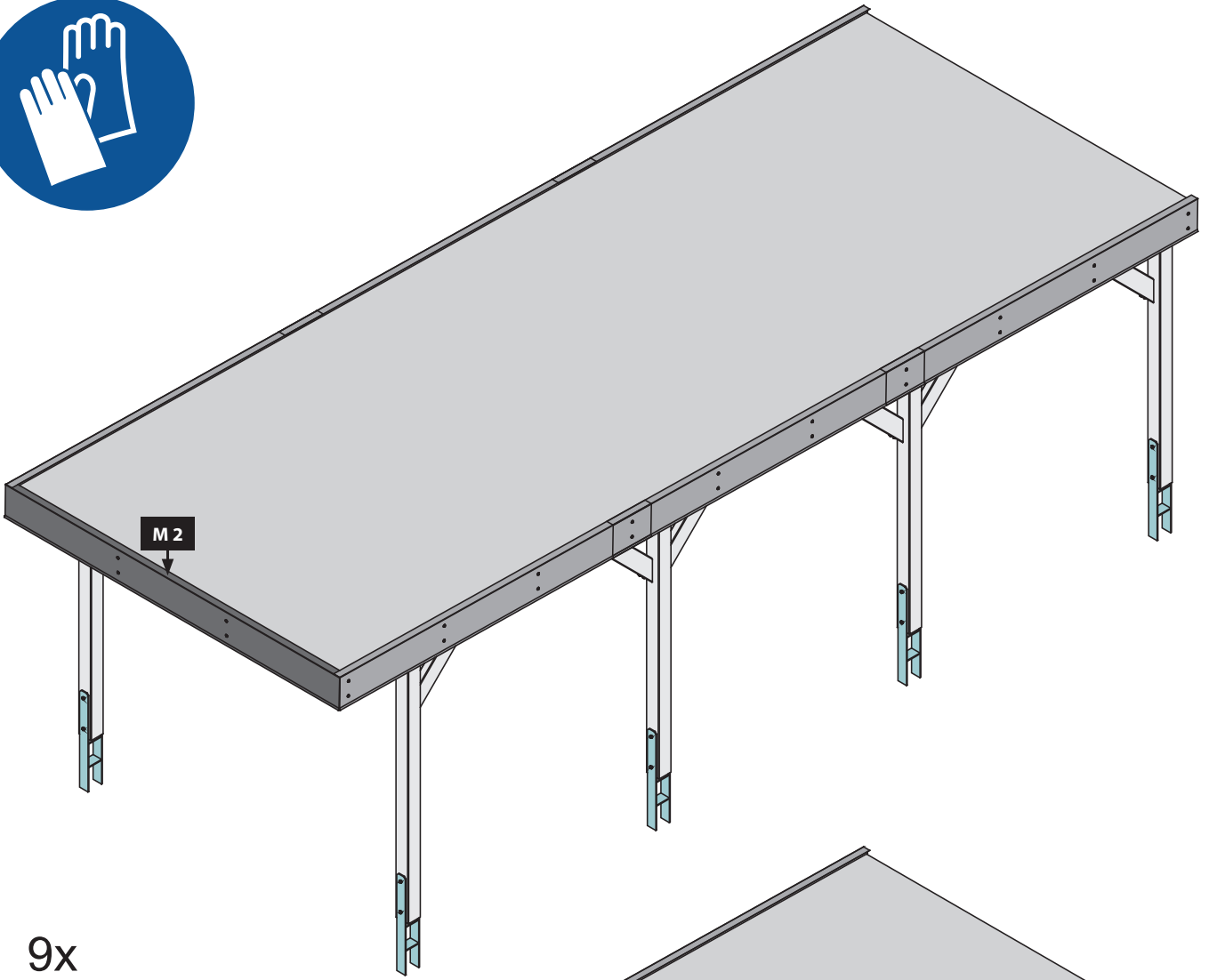





16x
Ø3 mm 4x25

A technical illustration of the hardware required for this step: a 3 mm diameter drill bit and a 4x25 mm screw.











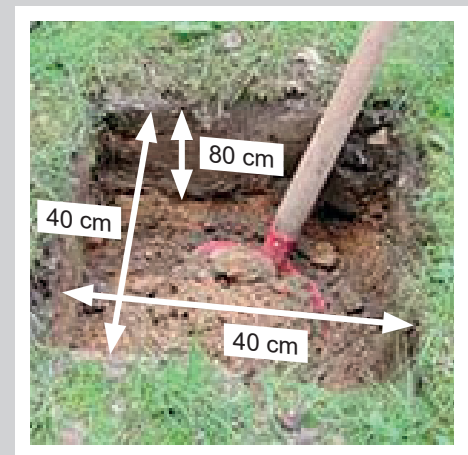

-  H-Pfostenanker montieren
-  Install concrete anchors
-  Ancres de béton installer

-  Betonankers installeren
-  Betonankre, der skal installeres
-  Anclas concretas instalar









-  Ancora di calcestruzzo installare
-  Instalovat betonové kotvy
-  Betonska sidra, ki jih je treba vgraditi

-  Eine Grube für jeden Pfosten ausheben
-  Dig a hole for each column
-  Creusez un trou pour chaque montant
-  Een put voor elke staander graven
-  Grav en grube til hver stolpe
-  Cavar un agujero por cada poste
-  Creare un foro per ogni montante
-  Jáma pro každé pracovní místo dig
-  Za vsako delovno mesto izkopljete jamo



-  Der H-Pfostenanker kann auf dem Brett in seiner Lage noch verändert werden
-  The position of the column joists can be altered due to their position on the plank
-  Les parties métalliques inférieures des montants peuvent encore être ajustées en fonction de leurs position respective sur les liteaux
-  De staanderdraggers kunnen door de positie op de plank qua positie nog veranderd worden
-  Søjlebælkenes placering kan ændres på grund af deres placering på planken
-  La posición de los portapostes puede variarse a su posición mediante la posición sobre la tabla
-  Le parti metalliche possono essere ancora aggiustate in funzione della loro posizione rispettiva sopra la tavola
-  H-post kotvy může být změněn na palubě na svém místě
-  Položaj nosilcev stebrov se lahko spremeni zaradi njihovega položaja na deski



-  Das Holzprodukt aufstellen. Die Pfosten in die H-Pfostenanker stellen. Etwas Abstand zwischen Pfostenende und Metall lassen. Die Pfosten durchbohren um sie mit den H-Pfostenankern zu verschrauben.
-  Position the pavilion. Insert the columns into the joists in the process. Drill holes in the columns in order to connect them to the joists by means of screws.
-  Positionnez le pavillon. Placez les montants dans leurs parties métalliques inférieures. Percez les montants afin de pouvoir ensuite les fixer et les visser aux parties inférieures métalliques. fonction de leurs position respective sur les liteaux
-  Het paviljoen opstellen. De staanders daarbij in de staanderdraggers stellen. Om de staanders met de dragers vast te schroeven, moeten de staanders doorgeboord worden.
-  Placer pavillonen. Sæt søjlerne ind i bjælkerne undervejs. Bor huller i søjlerne i for at forbinde dem til strøerne med skruer.
-  Colocar el pabellón. Colocar los postes en los portapostes. Perforar los postes para poderlos atornillar con los portapostes.
-  Posizionare il padiglione. Piazzare i montanti nelle loro parti metalliche. Per collegare i montanti con le parti metalliche è necessario perforare i montanti.
-  H-post kotvy může být změněn na palubě na svém místě
-  Postavite lesni izdelek. Postavite stebričke v sidra H-stebričkov. Med stebrički pustite nekaj prostora. koncem stebra in kovino. Prevrtajte stebre in jih privijte na sidra H-stebrov.



 H-Pfostenanker montieren

 Install concrete anchors

 Ancres de béton installer

 Betonankers installeren

 Betonankre, der skal installeres

 Anclas concretas instalar

 Ancora di calcestruzzo installare

 Instalovat betonové kotvy

 Betonska sidra, ki jih je treba vgraditi

 Eine Maschinenschraube vorsichtig durch die Öffnung des H-Pfostenankers einschlagen bis sie auf der anderen Seite wieder austritt.

 Carefully drill a drill screw through the opening in the concrete anchor and into the wood until the screw comes out the other side.

 Introduisez doucement dans le trou de la partie métallique, à l'aide d'un marteau, une vis d'assemblage à écrou, et cela jusqu'à ce qu'elle apparaisse de l'autre côté.

 Een machineschroef voorzichtig door de opening van het betonanker in het hout inslaan tot ze op de andere zijde naar buiten treedt.

 Drej forsigtigt en maskinskruer gennem åbningen i H-stolpeankeret, indtil den kommer ud på den anden side den kommer ud på den anden side.

 Introducir por percusión cuidadosamente un bulón ordinario en la madera a través de la apertura del anclaje de hormigón hasta que salga por el otro lado. Después aplanar el hormigón.

 Introdurre, facendo attenzione, una vite d'assemblaggio nel foro dell'ancora di calcestruzzo nel legno fino a quando essa non fuoriesce dall'altra parte.

 H-post kotvy může být změněn na palubě na svém místě

 Predvidno vtaknite strojni vijak skozi odprtino sidra H-stebra, dokler se ne pojavi na drugi strani. izstopi na drugi strani.



 Die Schraube mit Mutter und 2 Unterlegscheiben fixieren.

 Attach nuts to the screws.

 Vissez et serrez les vis à l'aide de boulons.

 De schroeven met moeren fixeren.

 Fastgør bolten med en møtrik og 2 skiver.

 Fijar los tornillos con las tuercas.

 Fissare le viti con l'aiuto dei bulloni.

 Šroub s maticí nebo 2 podložkami opravit.

 Vijak pritrdite z matico in dvema podložkama.

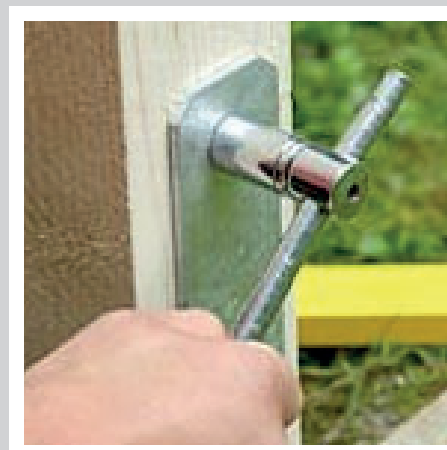

 Füllen Sie Beton in das ausgegrabene Loch. Der H-Pfostenanker bleibt weiterhin mit der Leiste fixiert. Danach den Beton glattstreichen.

 Fill the holes you have dug with concrete. The concrete anchor remains attached to the slat. Then, smooth out the concrete.

 Remplissez les trous creusés à l'aide de béton. Les parties inférieures métalliques des montants doivent encore rester maintenues en place à l'aide des liteaux. Nivelez ensuite le béton.

 Giet beton in de put. Het betonanker blijft verder met de lijst gefixeerd. Daarna de beton gladmaken.

 Fyld beton i det gravede hul. H-stolpeankeret forbliver fastgjort med afsatsen. Derefter udglattes betonen.

 Llene el agujero cavado con hormigón. El anclaje de hormigón continúa fijado con el listón.

 Riempire il foro incavato con del calcestruzzo. L'ancora in calcestruzzo continua a rimanere fissata con il listello. Livellare in seguito il calcestruzzo

 Vyplnit beton do vykopané díry. H-post kotvy zůstane připevněna k baru. Poté, co beton hladké.

 V izkopano luknjo napolnite beton. Sidro stebra H ostane pritrdjeno na polico. Nato beton zgladite.

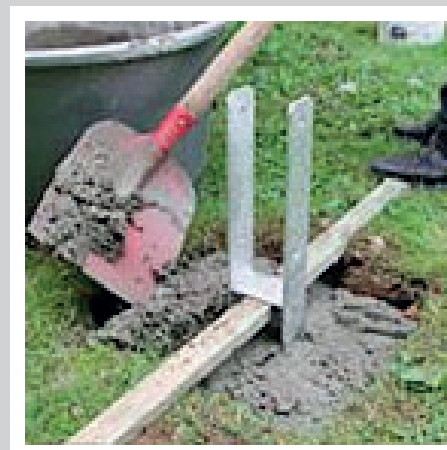



 H-Pfostenanker montieren

 Install concrete anchors

 Ancres de béton installer

 Betonankers installeren

 Betonankre, der skal installeres

 Anclas concretas instalar

 Ancora di calcestruzzo installare

 Instalovat betonové kotvy

 Betonska sidra, ki jih je treba vgraditi

 Fertig einbetonierter Pfosten.

 The posts are completely set in concrete.

 Montant installé et bétonné.

 Klaar ingebetonneerde staander.

 Færdigsat stolpe i beton.

 Poste hormigonado acabado.

 Montante installato e gettato nel calcestruzzo.

 Hotovo vybetonován příspěvek.

 Pripravljen stebriček v betonu.

