

# 1474

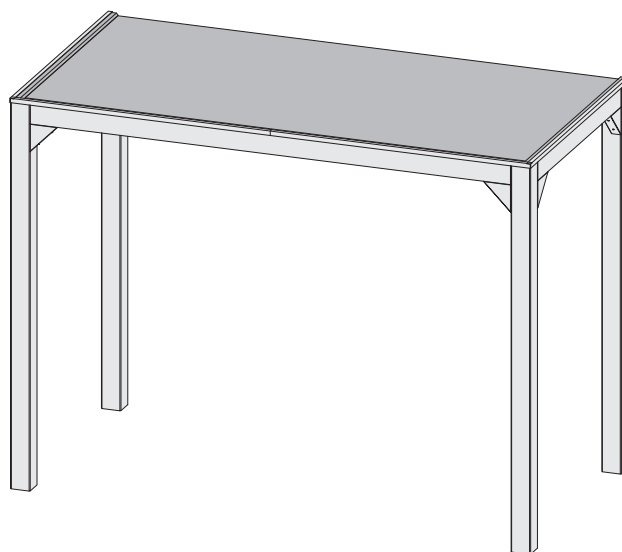

-  **Aufbauanleitung**
-  **Building Instructions**
-  **notice de montage**
-  **montagehandleiding**
-  **Montagevejledning**
-  **Instrucciones de construcción**
-  **Istruzioni per il montaggio**
-  **Montážní návod**
-  **Navodila za sestavljanje**

Bitte bewahren Sie die Anleitung und den Garantieschein zur Seriennummer auf.

Vernichten Sie diese erst nach Ablauf der Garantiezeit.

Eventuelle Beanstandungen können mithilfe der Stückliste einfacher zugeordnet werden.

#### Beigelegte Dokumente

- Informationsheft
- Garantieschein zur Seriennummer
- Typenschild inkl. Warnhinweise (Sauna)
- ggf. Zubehör-Anleitungen in externen Paketen

#### \*

-  Nicht im Lieferumfang enthalten
-  Not included
-  Non comprises dans la livraison
-  Niet bijgeleverd
-  No forman parte del suministro
-  Non incluso
-  V ceně není zahrnuto
-  Ikke inkluderet
-  Ni vključeno v obseg dobave









#### 2

-  Nicht gebraucht
-  Not needed
-  Pas nécessaire
-  Niet nodig
-  No es necesario
-  Non necessario
-  Není nutná
-  Ikke nødvendigt
-  Ne uporablja se

#### 4

-  Fixiert vorübergehend
-  Fixed temporarily
-  Temporairement fixe
-  Tijdelijk vast
-  Temporalmente fijo
-  Temporaneamente fisso
-  Dočasně pevný
-  Midlertidigt rettet
-  Začasno popravi

#### 1

-  Länge muss ermittelt und zugesägt werden
-  Length must be determined and sawn
-  La longueur doit être déterminée et sciée
-  De lengte moet worden bepaald en worden gezaagd
-  La longitud debe ser determinada y aserrada
-  La lunghezza deve essere determinata e segata
-  Délka musí být určena a rozřezána
-  Længden skal bestemmes og saves
-  Določiti je treba dolžino in jo odrezati po velikosti.

#### 3

-  Mit Zubehör
-  With accessories
-  Avec accessoires
-  Met toebehoren
-  Con accesorios
-  Con accessori
-  S příslušenstvím
-  Med tilbehør
-  Z dodatki

#### 5

-  Bestand vom Haus
-  Inventory of the house
-  Inventaire de la maison
-  Inventaris van het huis
-  Inventario de la casa
-  Inventario della casa
-  Inventář domu
-  Inventar af huset
-  Inventarizacija hiše

 Vergleichen Sie zuerst die Material-liste mit Ihrem Paketinhalt! Bitte haben Sie Verständnis, dass Beanstandungen nur im nicht aufgebauten Zustand bearbeitet werden können!

 First compare the list of materials with your package contents! Please understand that complaints can be processed in the non-built status only!

 Commencez par comparer la liste du matériel avec le contenu de votre paquet! Sachez que nous traitons uniquement les réclamations concernant le matériel à l'état non monté!

 Vergelijk eerst de lijst van materialen met de inhoud van uw pakket! Reclamaties kunnen alleen in behandeling worden genomen zolang de onderdelen nog niet zijn gemonteerd!

 Start med at kontrollere materialelisten med indholdet af den leverede pakke! Vi gør venligst opmærksom på at reklamationer kun kan behandles for materialer som ikke er blevet bearbejdet!

 En primer lugar, compare la lista de material con el contenido del paquete. Rogamos entienda que las reclamaciones sólo pueden ser tramitadas antes de montar el objeto!

 Confrontate questa distinta materiali prima con il contenuto del pacchetto! Vi preghiamo di comprendere che eventuali reclami possono essere accolti solo prima del montaggio!

 Nejprve přezkontrolujte obsah balení podle materiálového listu! Mějte pochopení pro to, že případnou reklamaci se můžeme zabývat pouze tehdy, když díly nebudou smontované! Za pomoci tohoto seznamu můžete jednotlivé díly přiřadit k montážnímu návodu.

 Najprej primerajte zoznam materialov z vsebino vašega paketa! Upoštevajte, da lahko pritožbe obravnavamo le v nesestavljenem stanju!

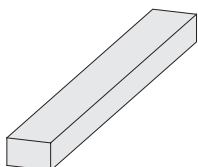

2 x <b>A1</b>	1154 x 18 x 58 mm	ID 1492
2 x <b>A2</b>	1294 x 28 x 58 mm	ID 1493
3 x <b>A3</b>	1468 x 100 x 60 mm	ID 60341
2 x <b>A4</b>	1350 x 120 x 60 mm	ID 1494
2 x <b>A5</b>	2952 x 120 x 60 mm	ID 60345
4 x <b>A6</b>	2350 x 120 x 120mm	ID 59422

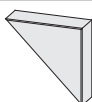

8 x <b>B1</b>	240 x 120 x 60 mm	ID 61608
---------------	-------------------	----------

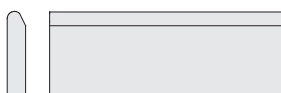

5 x <b>B2</b>	2000 x 18 x 58 mm	ID 48545
---------------	-------------------	----------



17 x <b>R1</b>	3070 x 96 x 19 mm	ID 60416
----------------	-------------------	----------



2 x <b>Q1</b>	5 x 1 m 5 m <sup>2</sup>	ID 77453
---------------	--------------------------	----------



4 x <b>Y1</b>	1600 x 30 x 30 mm	ID 61695
---------------	-------------------	----------



140 x	4 x 30mm	ID 3686
15 x	6 x 80mm	ID 47558

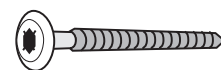

20 x	6 x 140mm	ID 97980
------	-----------	----------

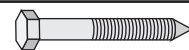

35 x	10 x 50mm	ID 61606
------	-----------	----------

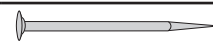

100 x	2 x 50 mm	ID 5621
-------	-----------	---------



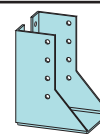

8 x	90 x 50 x 80 mm	ID 61605
-----	-----------------	----------



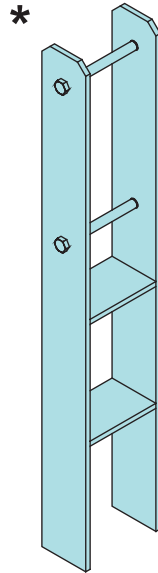

6 x	100 x 60 mm	ID 59443
-----	-------------	----------





 Die Pfosten dieses Produkts sollten fest mit dem Untergrund verbunden werden. Dazu empfehlen wir H-Pfostenanker. Diese sollten erst nach dem Aufbau dieses Produkts endgültig mit Beton versehen werden. Die H-Pfostenanker und das zugehörige Befestigungsmaterial sind nicht im Lieferumfang dieses Produkts enthalten.

 The posts of this product should be firmly connected to the ground. We recommend H-post anchors. These should only be finally provided with concrete after the construction of this product. The H-post anchors and associated fasteners are not included with this product.

 Les poteaux de cet article doivent être fixés au sol. A cet effet, nous vous recommandons les systèmes d'ancrage en H (accessoires non fournis avec le produit). Ceux-ci doivent être scellés avec du béton une fois la construction du produit terminée.

 De berichten van dit product moet op de grond vastgemaakt. Wij bevelen ook het H-bericht ankers. Deze dienen echter pas na de uiteindelijke structuur van het product met beton worden. De H-paal ankers en de bijbehorende bevestigingsmaterialen worden niet meegeleverd met dit product.

 Los mensajes de este producto debe fijarse al suelo. También te recomendamos anclas H-post. Estos deben ser proporcionados sólo después de la estructura final del producto de hormigón. Los anclajes H-correos y los materiales de fijación asociados no están incluidos con este producto.

 I messaggi di questo prodotto devono essere fissati al suolo. Noi raccomandiamo anche ancore H-post. Questi dovrebbero essere forniti solo dopo che la struttura finale del prodotto con calcestruzzo. Le ancore H-post ed i materiali di fissaggio associati non sono inclusi con questo prodotto.

 Stolperne på dette produkt skal være solidt forbundet med jorden. Vi anbefaler H-stolpeankre til dette formål. Disse skal først fyldes med beton, når produktet er blevet samlet. H-stolpeankrene og de tilhørende fastgørelsesmaterialer er ikke inkluderet i dette produkt.

 Sloupky tohoto produktu by měla být stanovená na zem. Doporučujeme také H-post kotvy. Ty by měly být poskytnuty pouze po konečnou strukturu výrobku s betonem. H-post kotvy a příslušné upevňovací materiály nejsou součástí tohoto produktu.

 Stebri tega izdelka morajo biti trdno povezani z zemljo. V ta namen priporočamo sidra v obliki stebra H. Te je treba dokončno zapolniti z betonom šele po montaži tega izdelka. Sidro za stebričke H in pripadajoči pritrilni material nista priložena temu izdelku.

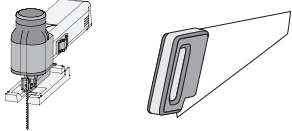
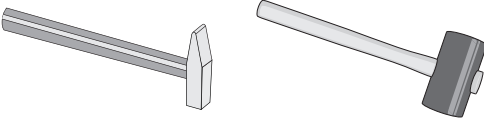
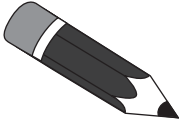
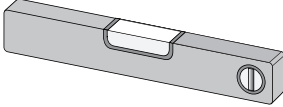
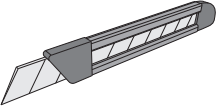
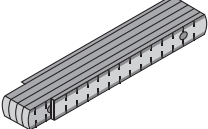
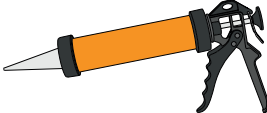
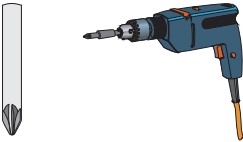
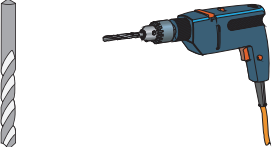
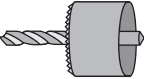
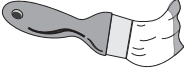
Werkzeuge / Tools*	
X	
X	
X	
X	
X	
X	
X	
X	
X	
	
X	

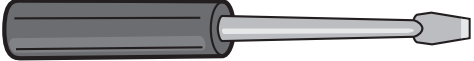
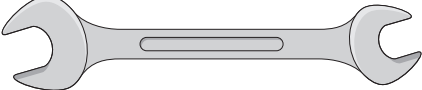
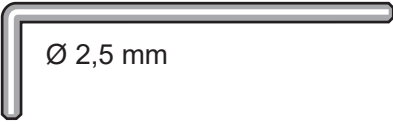
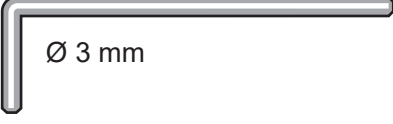
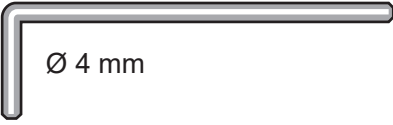
Werkzeuge / Tools*	
X	
X	
X	
X	 Ø 2,5 mm
X	 Ø 3 mm
X	 Ø 4 mm



01

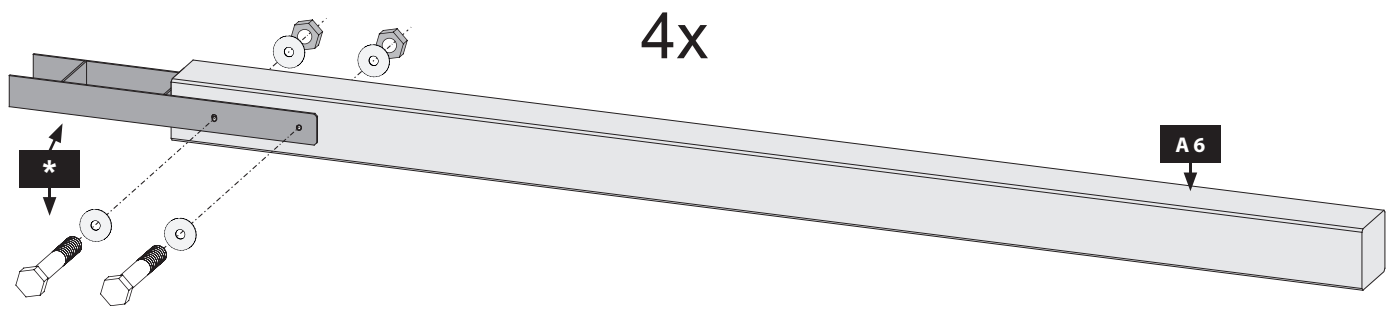

02

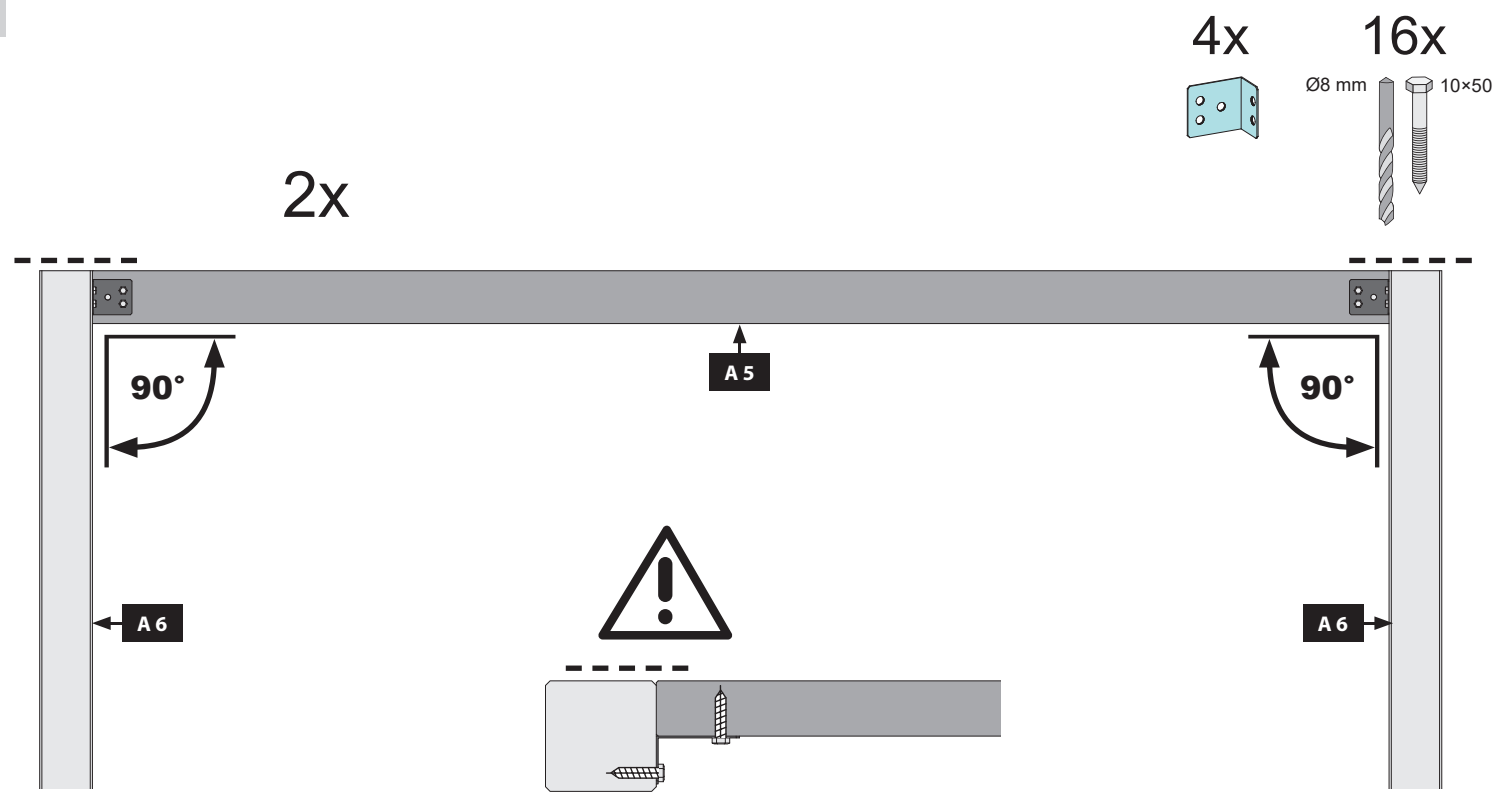

03

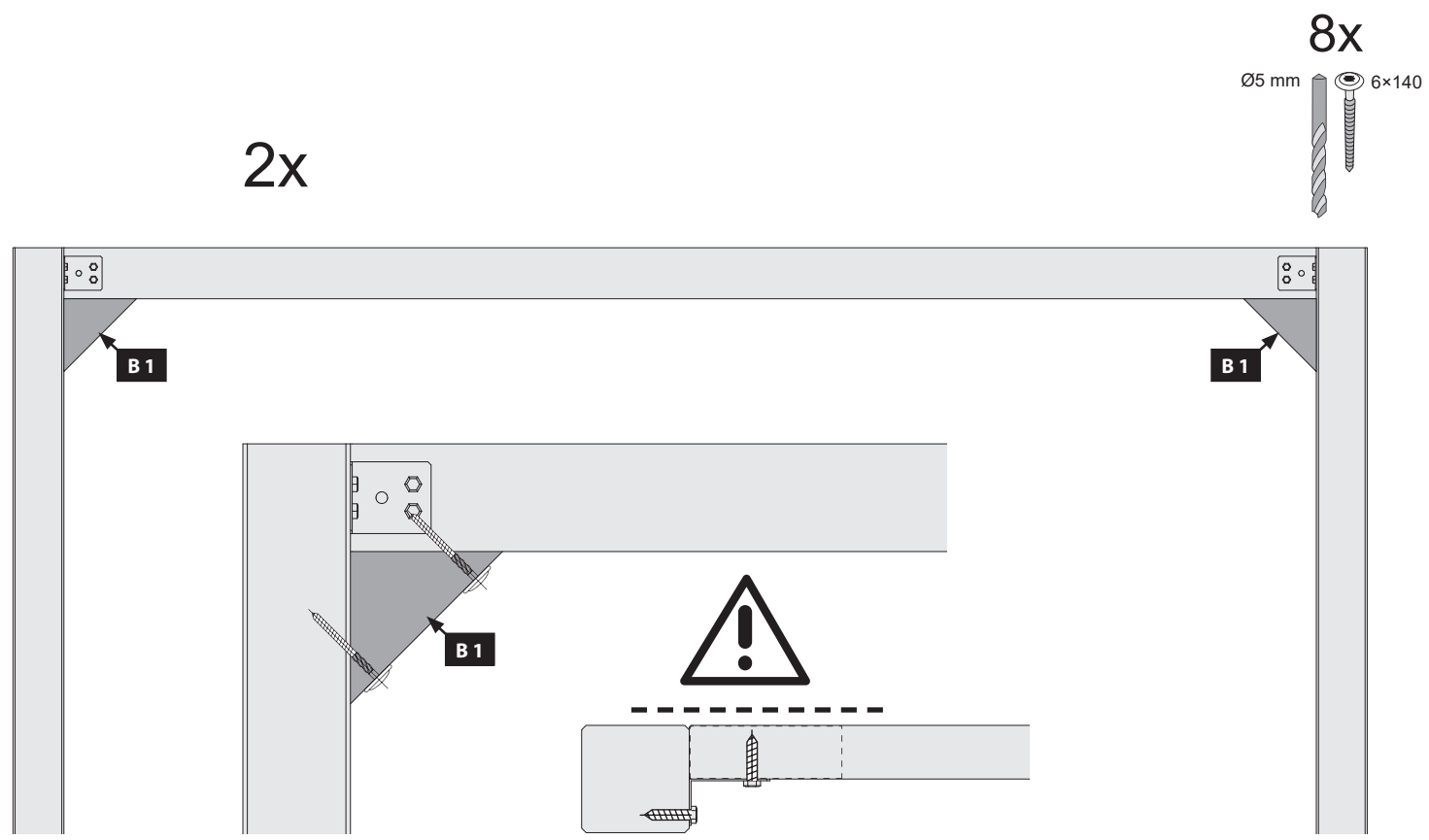

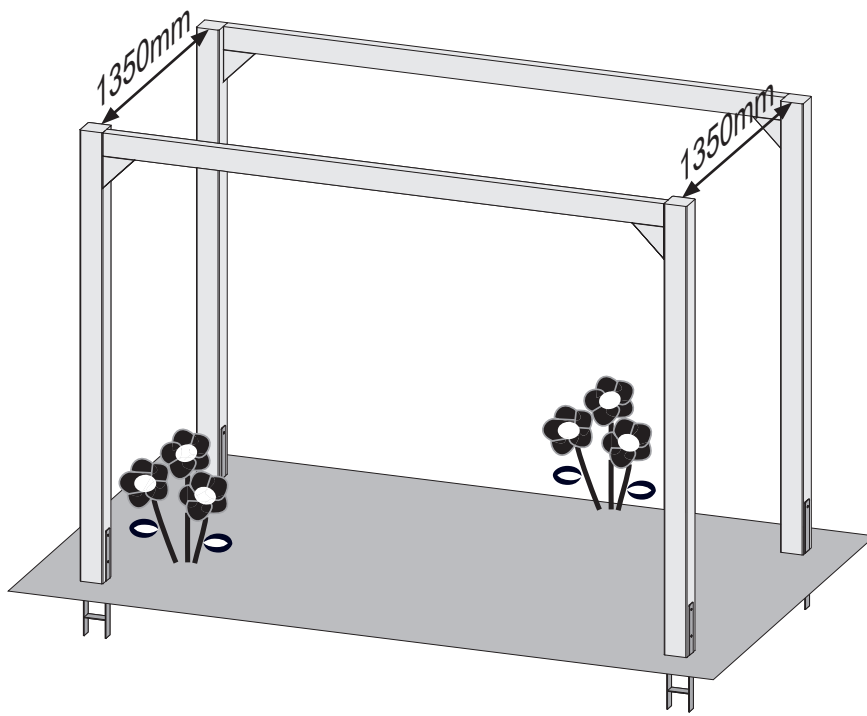

04

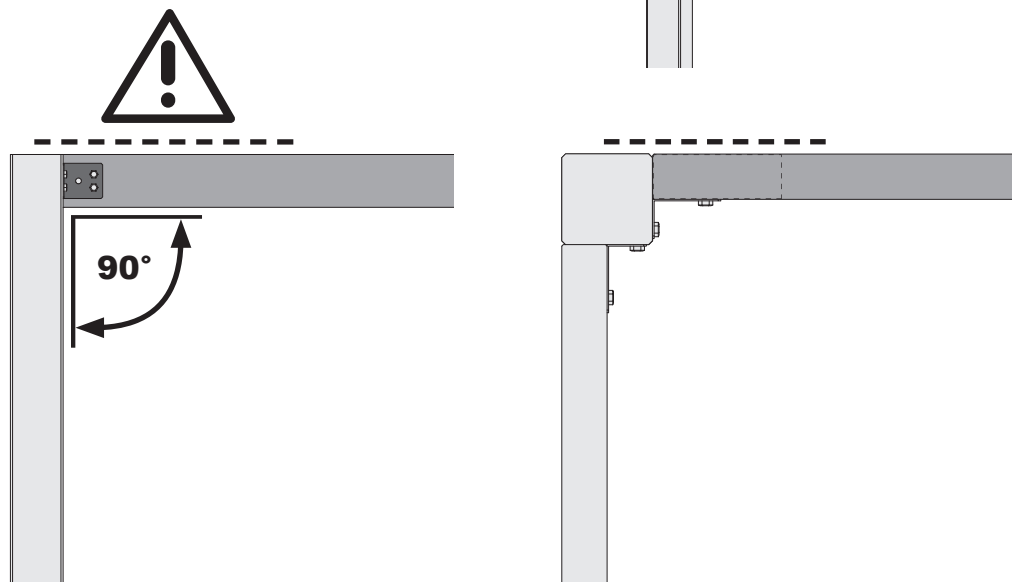
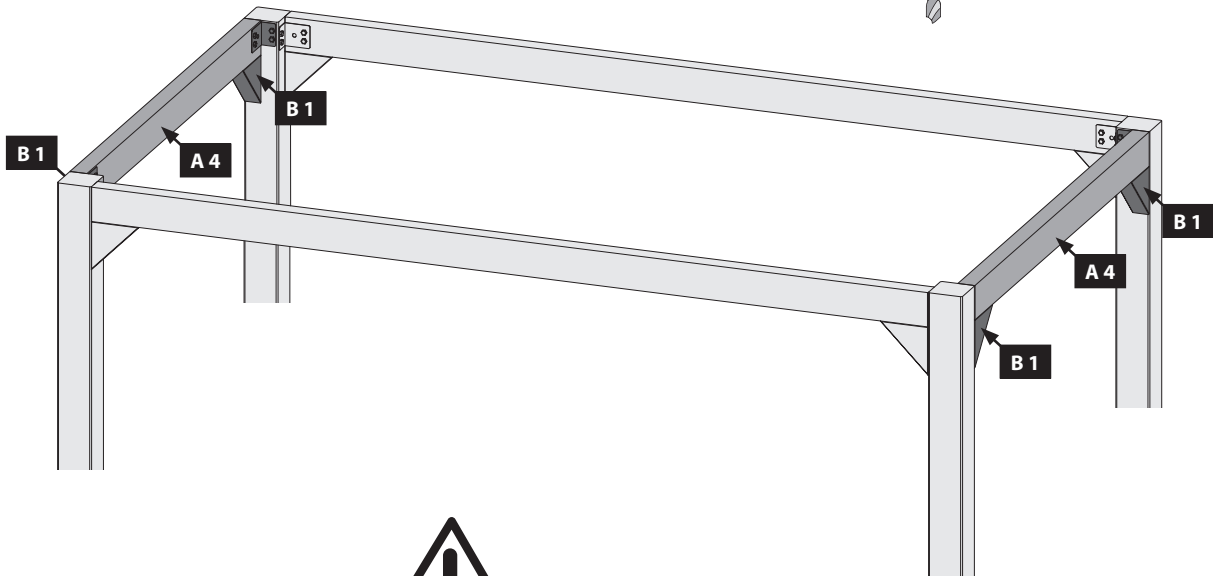
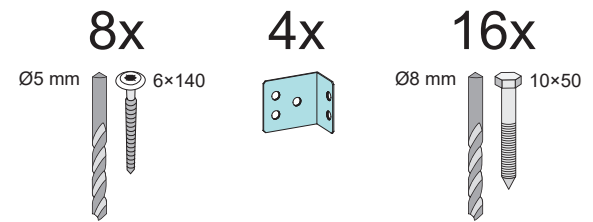

6x

84x

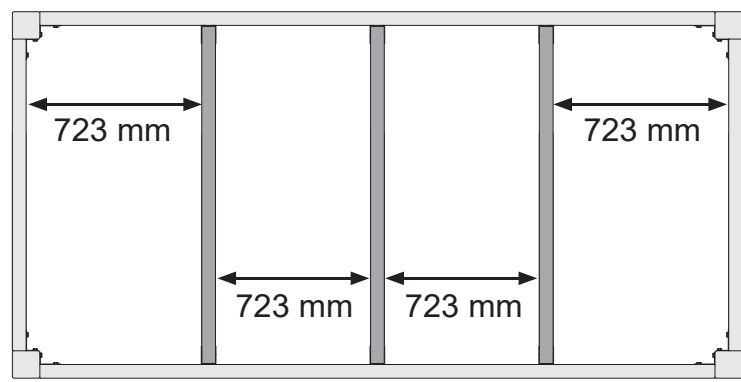
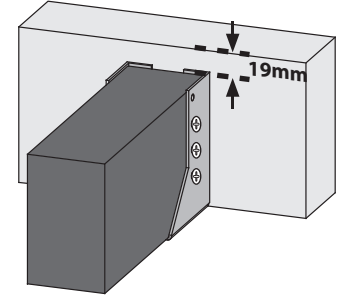
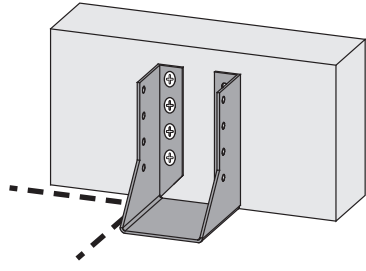
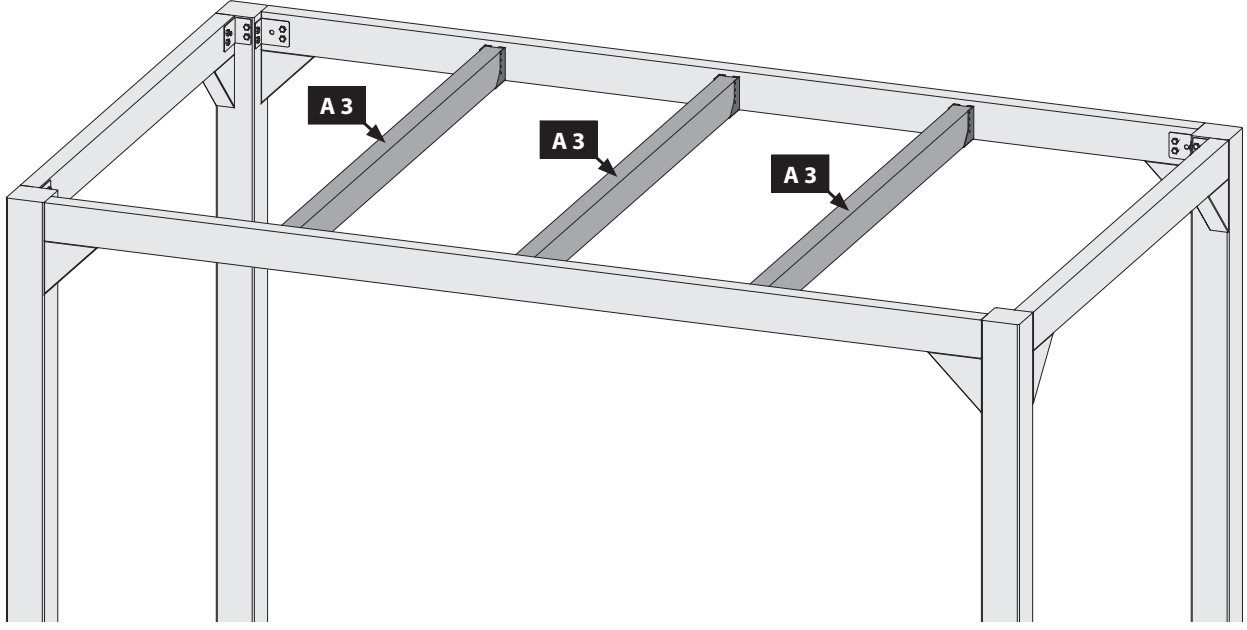
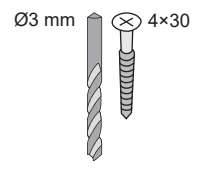

06

12x

Ø5 mm 6x80

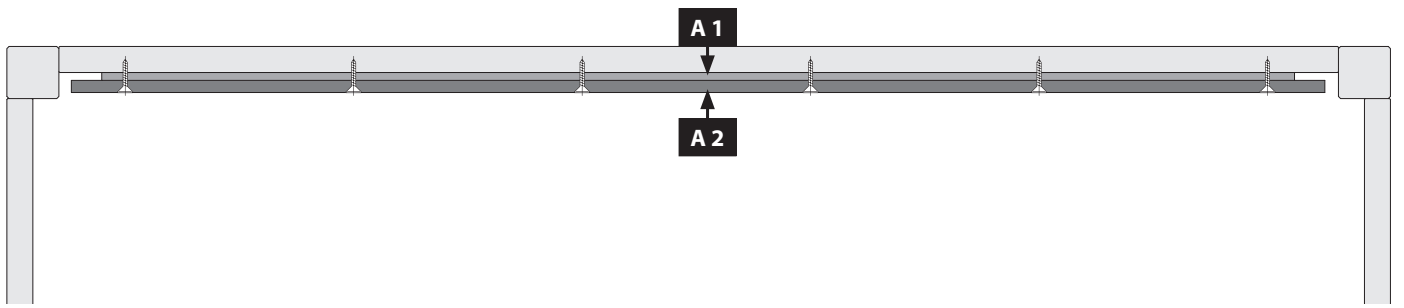
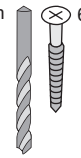
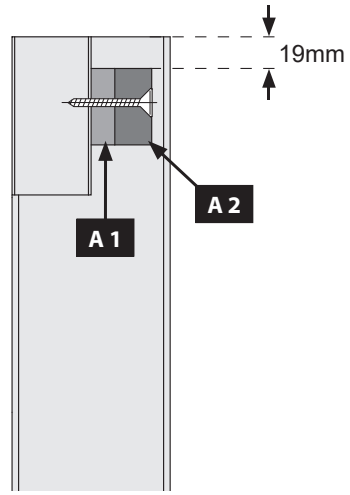
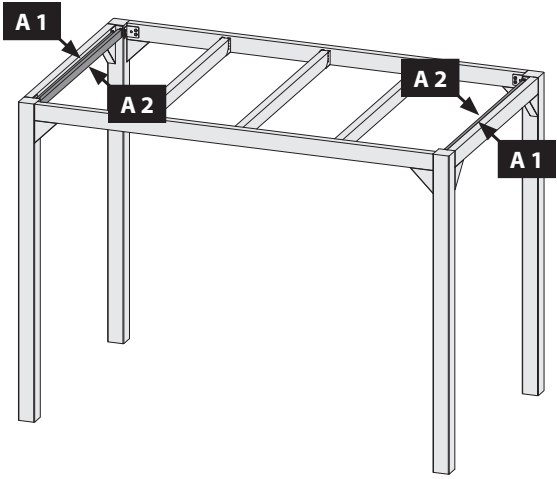

07

17x

R1

~83x

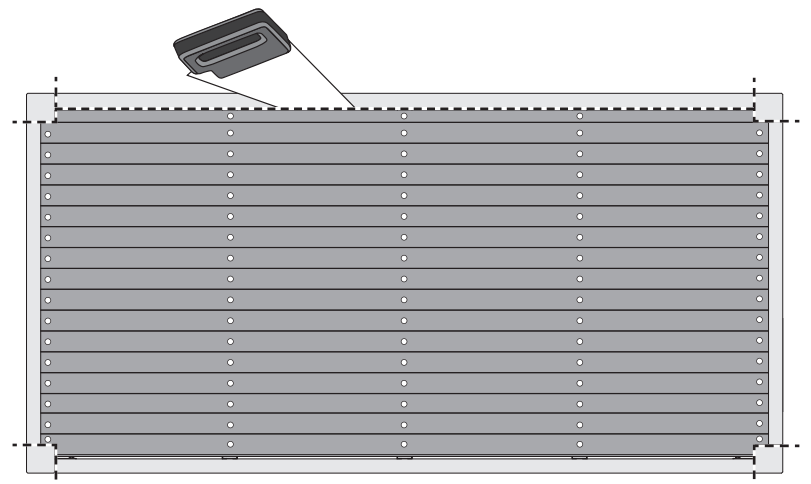
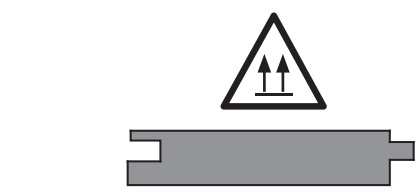
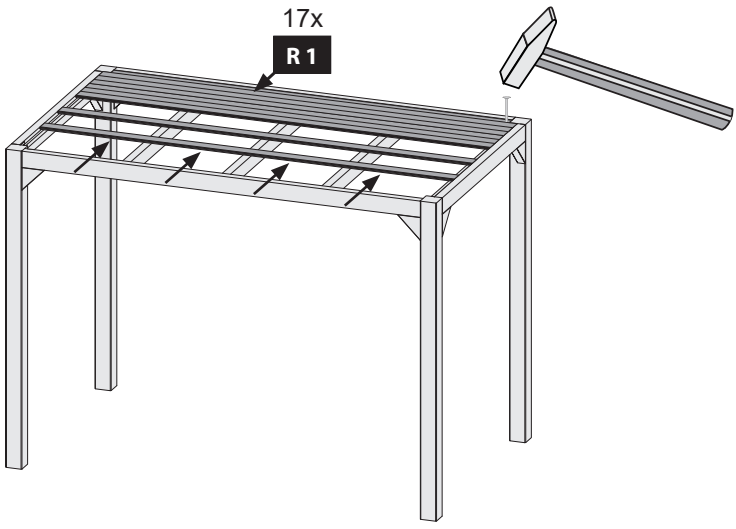

08

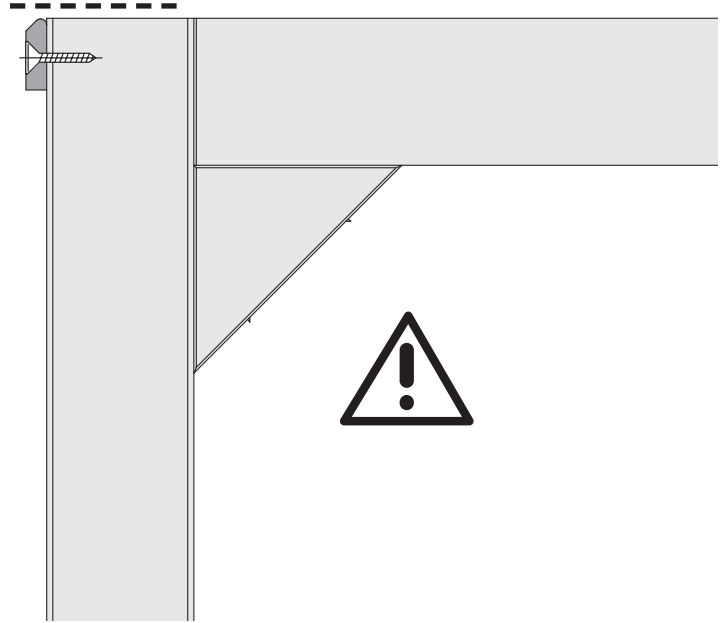
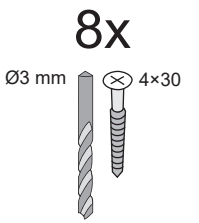
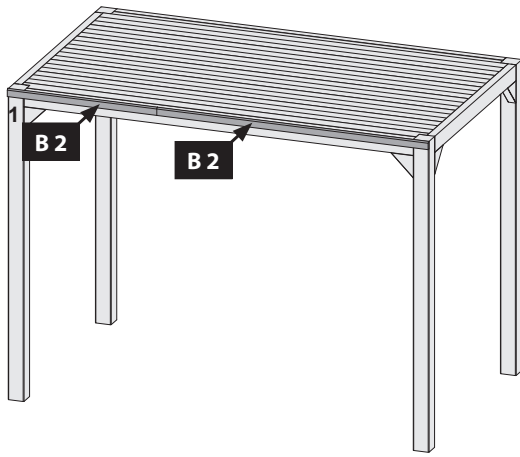

09

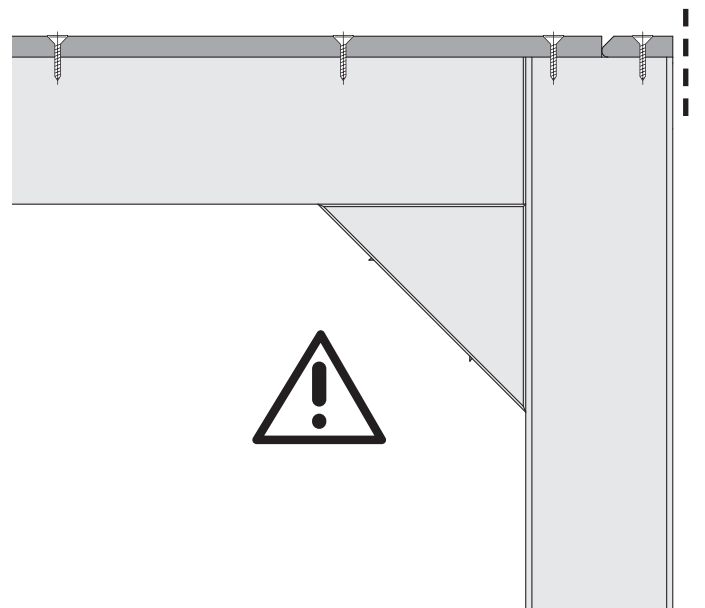
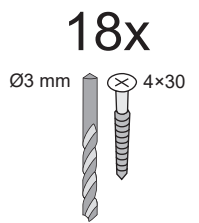
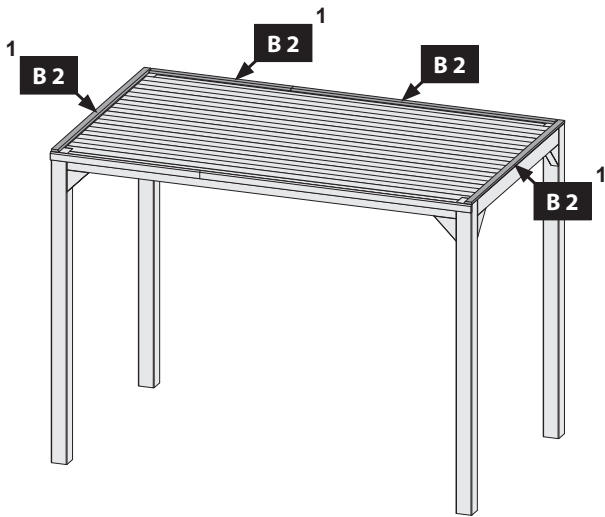

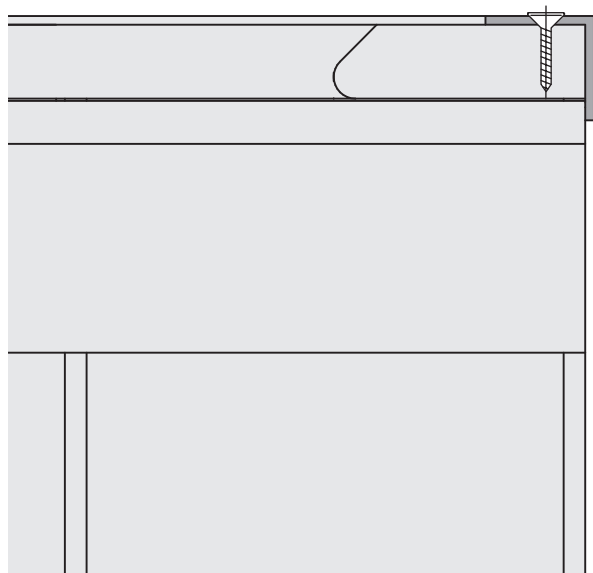
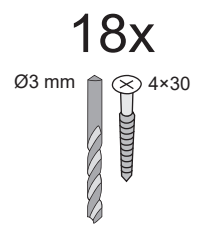
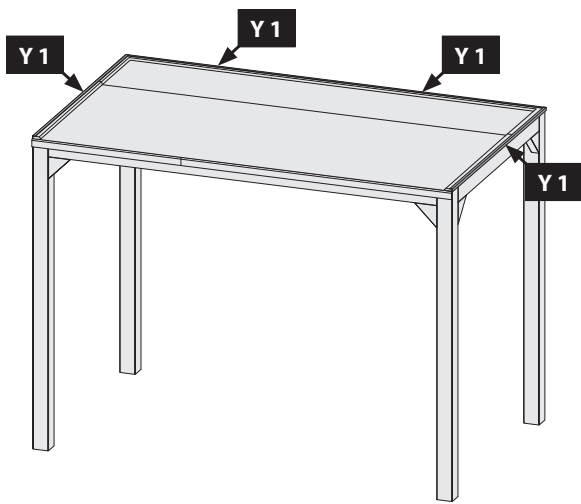
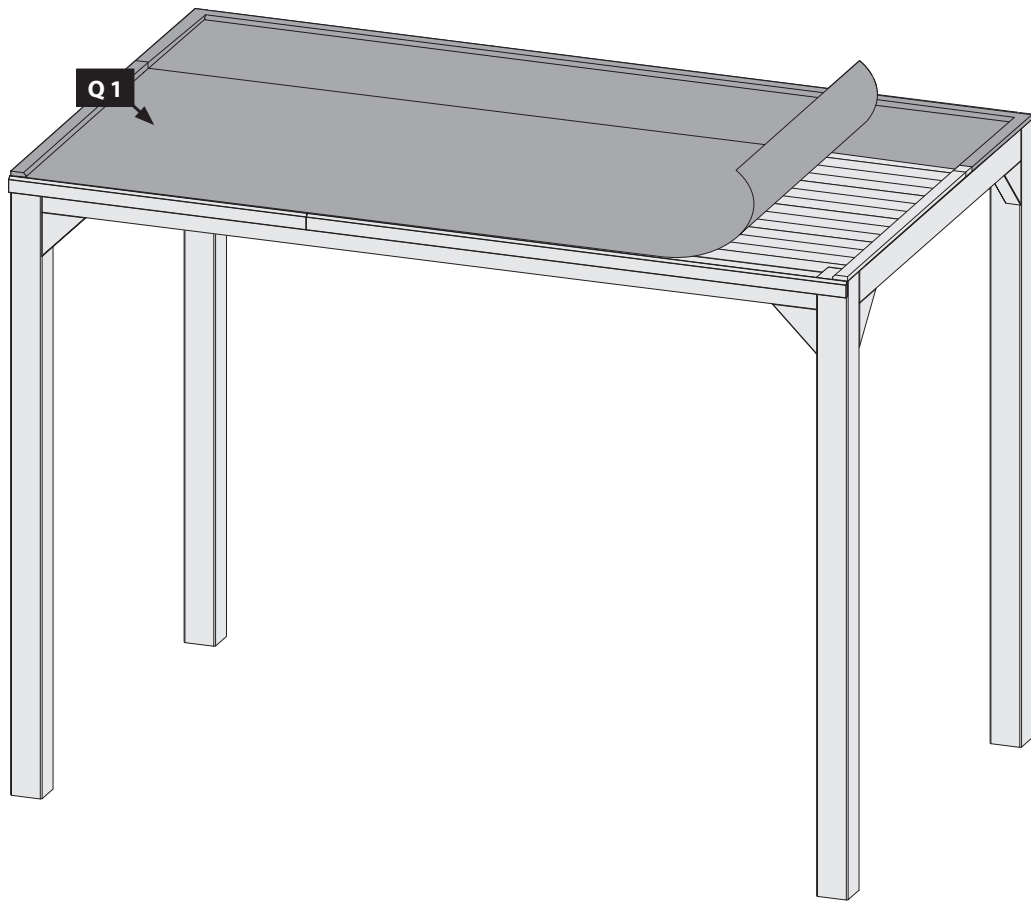



# 77453





-  **Aufbauanleitung**
-  **Building Instructions**
-  **notice de montage**
-  **montagehandleiding**
-  **Montagevejledning**
-  **Instrucciones de construcción**
-  **Istruzioni per il montaggio**
-  **Montážní návod**
-  **Navodila za sestavljanje**

 Vergleichen Sie zuerst die Material-liste mit Ihrem Paketinhalt! Bitte haben Sie Verständnis, dass Beanstandungen nur im nicht aufgebauten Zustand bearbeitet werden können!

 First compare the list of materials with your package contents! Please understand that complaints can be processed in the non-built status only!

 Commencez par comparer la liste du matériel avec le contenu de votre paquet! Sachez que nous traitons uniquement les réclamations concernant le matériel à l'état non monté!

 Vergelijk eerst de lijst van materialen met de inhoud van uw pakket! Reclamaties kunnen alleen in behandeling worden genomen zolang de onderdelen nog niet zijn gemonteerd!

 Start med at kontrollere materialelisten med indholdet af den leverede pakke! Vi gør venligst opmærksom på at reklamationer kun kan behandles for materialer som ikke er blevet bearbejdet!

 En primer lugar, compare la lista de material con el contenido del paquete. Rogamos entienda que las reclamaciones sólo pueden ser tramitadas antes de montar el objeto!

 Confrontate questa distinta materiali prima con il contenuto del pacchetto! Vi preghiamo di comprendere che eventuali reclami possono essere accolti solo prima del montaggio!

 Nejprve přezkontrolujte obsah balení podle materiálového listu! Mějte pochopení pro to, že případnou reklamaci se můžeme zabývat pouze tehdy, když díly nebudou smontované! Za pomoci tohoto seznamu můžete jednotlivé díly přiřadit k montážnímu návodu.

 Najprej primerajte zoznam materialov z vsebino vašega paketa! Upoštujte, da lahko pritožbe obravnavamo le v nesestavljenem stanju!

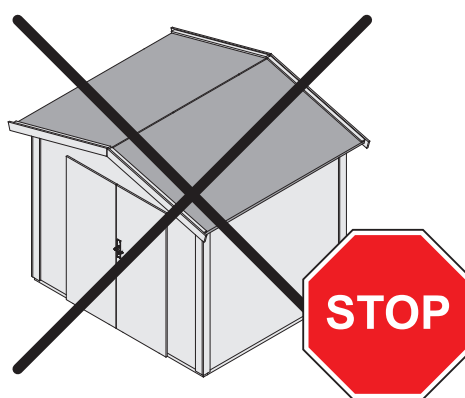
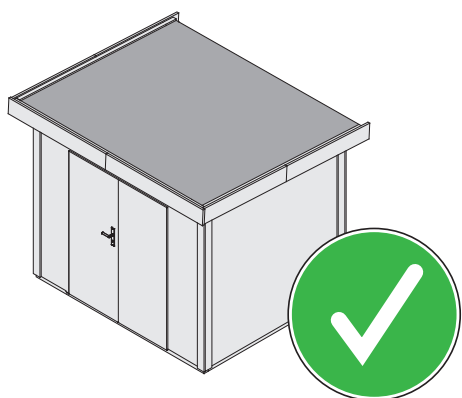
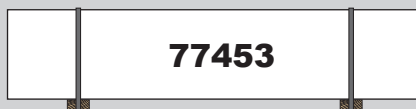

01

 Das Dach muss sauber und trocken sein!

 The roof must be clean and dry!

 Le toit doit être propre et sec!

 Het dak moet schoon en droog zijn!

 Taget skal være rent og tørt!

 ¡El techo debe estar limpio y seco!

 Il tetto deve essere pulito e asciutto!





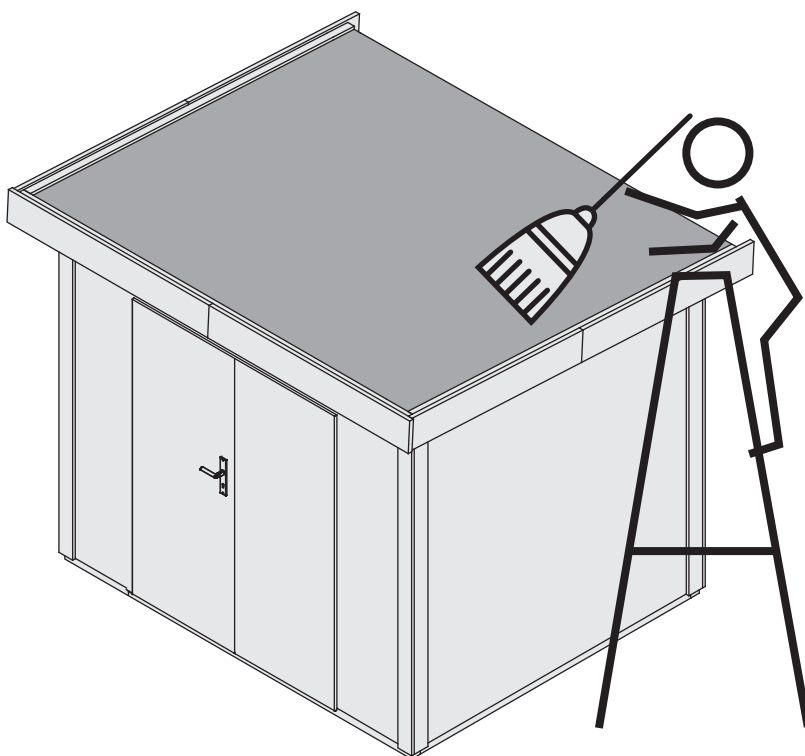

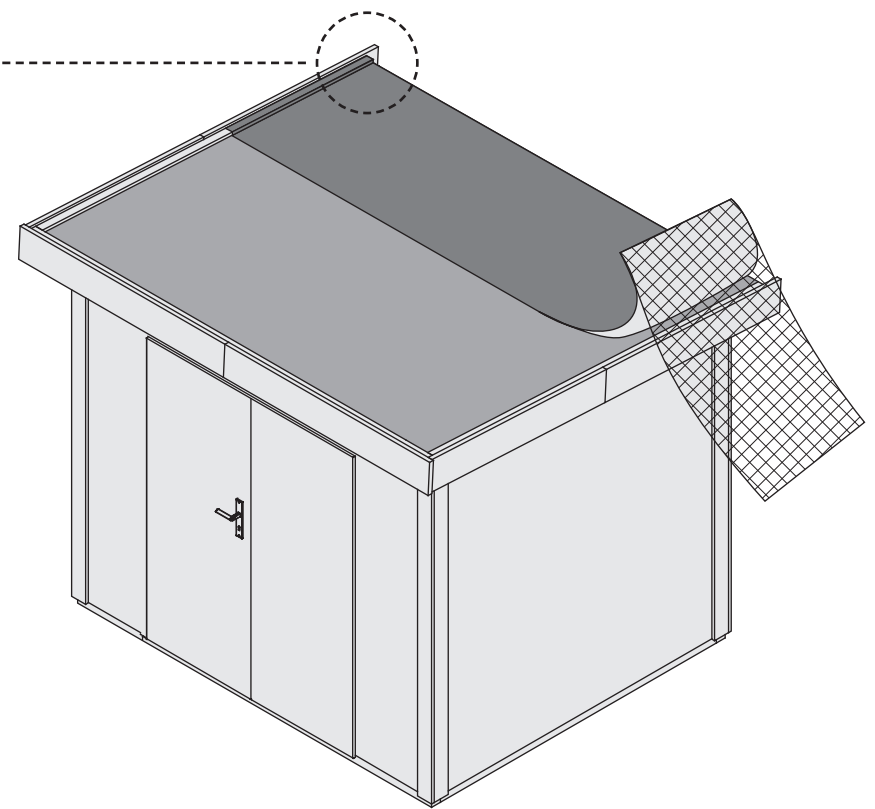
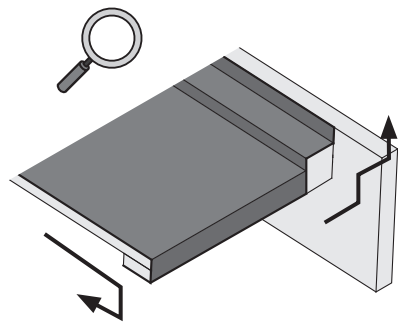
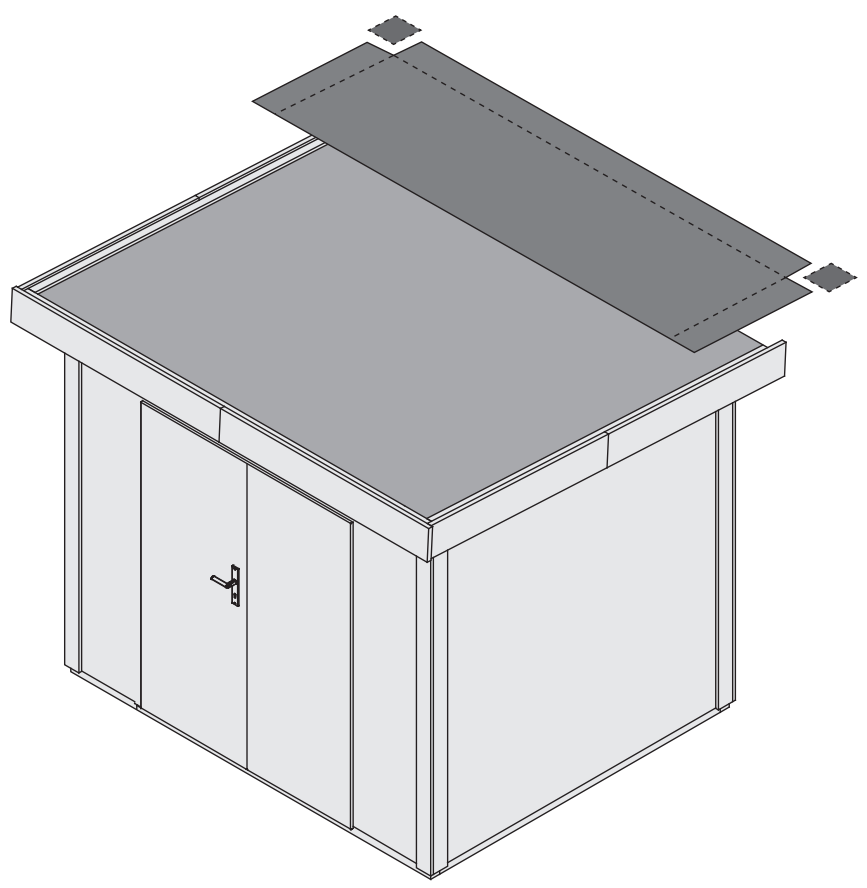
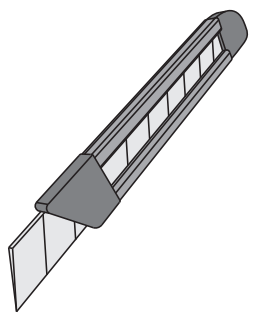

 Střecha musí být čistá a suchá!

 Streha mora biti čistá in suha!



-  Zuschneiden
-  Cut out
-  Découper
-  Uitsnijpen
-  Skåret ud
-  Cortar
-  Ritagliare
-  Vystřihnout
-  Pridelki



-  Fest verkleben. Beginnend hinten.
-  Stick firmly. Starting at the back.
-  Collez fermement. Partir à l'arrière.
-  Blijf stevig plakken. Beginnend aan de achterkant.
-  Hold fast. Fra bagsiden.
-  Mantente firme. Comenzando por la parte de atrás.
-  Stick saldamente. A partire dal retro.
-  Pevně se držte. Začíná vzadu.
-  Trdno prilepite. Začnite na zadnji strani.

-  ≈ 100 mm Überlappung der Folie
-  ≈ 100 mm overlap of the film
-  ≈ Coverage couverture du film de 100 mm
-  ≈ 100 mm dekking van de film
-  ≈ 100 mm overlaping af filmen
-  ≈ Coverage 100 mm de cobertura de la película
-  ≈ 100 mm di copertura del film
-  ≈ Coverage 100 mm pokrytí filmu
-  ≈ 100 mm prekrivanje folije

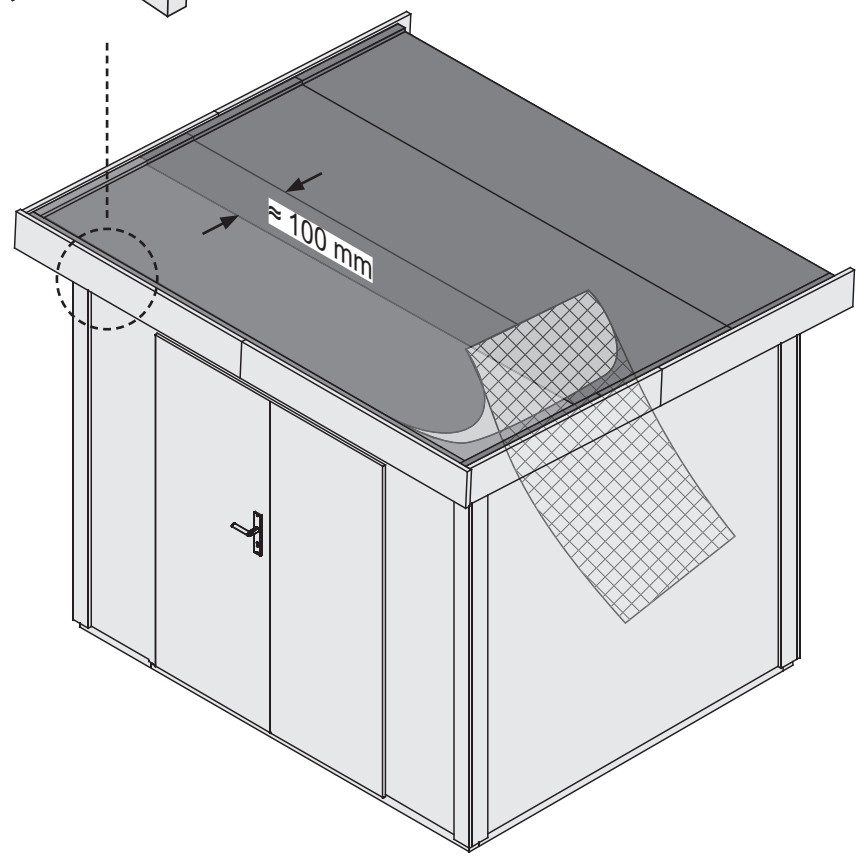
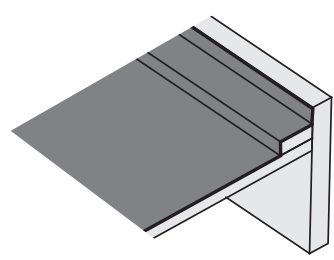
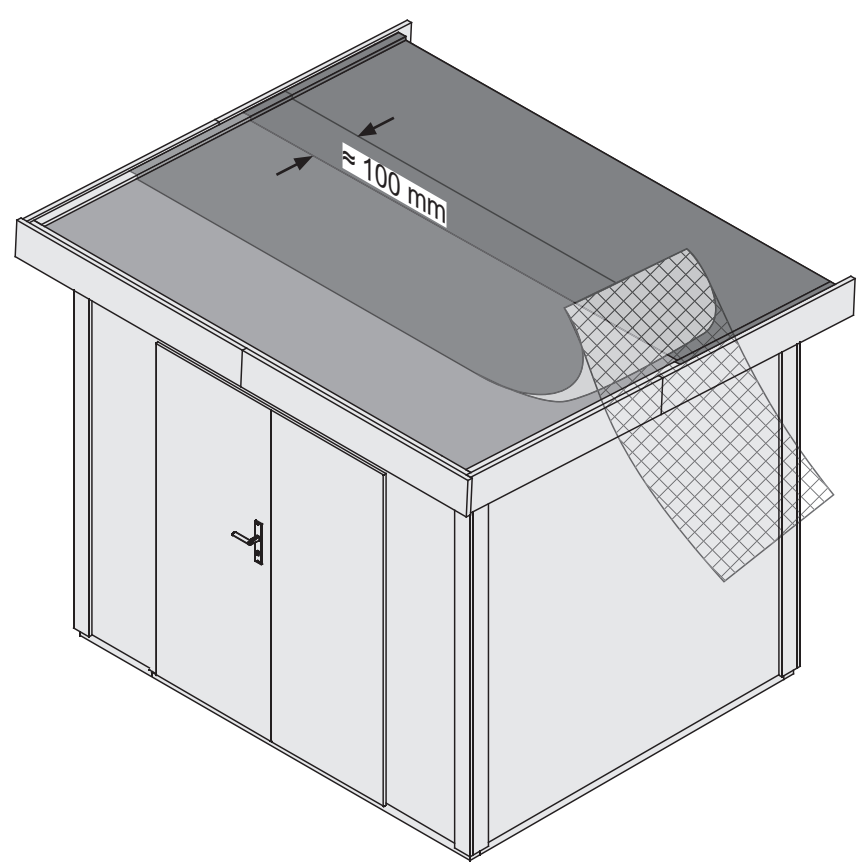

# SELBSTKLEBENDE DACHFOLIE

nach DIN EN 13970/ DIN 18234



## Produktbeschreibung

Die selbstklebende Bitumendachbahn ist eine kalt zu verarbeitende Dachbahn auf Bitumenbasis. Die Deckschicht besteht aus einer hochwertig lackierten Aluminiumfolie. Das Produkt eignet sich ideal zur Abdichtung von leicht geneigten Gartenhausdächern. Es zeichnet sich durch einfache Verlegung ohne Flammeneinsatz und hervorragende Klebkraft aus. Der Decklack ist UV-beständig.

## Untergrundvorbereitung

Der Untergrund muss trocken staubfrei silikonfrei fettfrei und abriebfest sein. Lose Bestandteile sind vorher zu entfernen. Verschmutzte Untergründe sind vorher mit bituminösem Voranstrich (lösemittelhaltig oder lösemittelfrei) einzustreichen. Hierbei ist unbedingt darauf zu achten, dass der Voranstrich vor Aufbringung der Dachfolie vollständig getrocknet ist.

## Verarbeitung

Das Verlegen der Bahn erfolgt längs zum Gefälle. Zunächst wird die Dachfolie auf einem schmalen Streifen von ca. 10 cm abgezogen und vorsichtig auf dem Dach angelegt und ausgerichtet. Anschließend wird die Bahn gleichmäßig abgerollt und vorsichtig angelegt. Dabei ist darauf zu achten, dass sich keine Lufteinschlüsse bilden. Der Überlappungsbereich sollte 10 cm betragen. Insbesondere im Überlappungsbereich sollte zum Erreichen einer optimalen Verklebung die Bahn angewalzt werden.

## Technische Daten

<b>Flächenbezogene Masse</b>	1,1 kg/m <sup>2</sup> / 1,5 kg/m <sup>2</sup> ± 0,2 kg/m <sup>2</sup>	DIN EN 1849-1
<b>Komplette Banddicke</b>	1,1 mm/ 1,5 mm ± 0,2 mm	DIN EN 1849-1
<b>Erweichungspunkt</b>	≥ 85 °C	DIN EN 1427
<b>Kaltbiegeverhalten</b>	≤ -20 °C	DIN EN 1109
<b>Höchstzugkraft</b>	> 200 N/50 mm	DIN EN 12311-1
<b>Wasserdichtheit</b>	bestanden 2 kPa	DIN EN 1928
<b>Wasserdampfdurchlässigkeit sd</b>	> 1500 m	DIN EN 1931
<b>Klebkraft</b>	> 30 N/25 mm	DIN EN 1939

## Lagerung

Das Produkt sollte vor direkter Sonnenstrahlung geschützt und bei 10 °C bis 30 °C gelagert werden. Die Rollen sollten außerdem trocken und stehend aufbewahrt werden. Das Produkt ist nicht frostgefährdet. Die Eigenschaften der Dachfolie bleiben lange Zeit unverändert. Eine Verarbeitung innerhalb von 12 Monaten wird empfohlen.

# SAMOLEPILNA STREŠNA FOLIJA

DIN EN 13970/ DIN 18234



## Opis izdelka

Samolepilna bitumenska strešna membrana je hladno nanesena strešna membrana na osnovi bitumna. Zgornji sloj je sestavljen iz visokokakovostne prevlečene aluminijaste folije. Izdelek je idealen za hidroizolacijo rahlo nagnjenih streh vrtnih lop. Odlikujeta ga preprosta vgradnja brez uporabe plamena in odlična lepilna trdnost. Vrhnji sloj je odporen na UV-žarke.

## Priprava substrata

Podlaga mora biti suha, brez prahu, brez silikona, maščobe in odporna na obrabo. Ohlapne sestavne dele je treba predhodno odstraniti. Umazane podlage je treba najprej premazati z bitumenskim temeljnim premazom (na osnovi topil ali brez topil). Pred nanosom strešne membrane je treba zagotoviti, da je temeljni premaz popolnoma suh.

## Obdelava

Membrana je položena vzdolž pobočja. Najprej se strešna membrana odstrani z ozkega, približno 10 cm dolgega pasu ter se previdno položi in poravna na streho. Membrana se nato enakomerno razgrne in previdno položi. Prepričajte se, da ne nastajajo zračni žepi. Območje prekrivanja mora biti 10 cm. Predvsem na območju prekrivanja je treba membrano povaljati, da se doseže optimalen oprijem.

## Tehnični podatki

Masa na enoto površine	1,1 kg/m <sup>2</sup> / 1,5 kg/m <sup>2</sup> ± 0,2 kg/m <sup>2</sup>	DIN EN 1849-1
Celotna debelina pasu	1,1 mm/ 1,5 mm ± 0,2 mm	DIN EN 1849-1
Točka mehčanja	≥ 85 °C	DIN EN 1427
Obnašanje pri hladnem upogibanju	≤ -20 °C	DIN EN 1109
Največja natezna sila	> 200 N/50 mm	DIN EN 12311-1
Vodotesnost	posredovano 2 kPa	DIN EN 1928
Prepustnost za vodno paro sd	> 1500 m	DIN EN 1931
Moč lepila	> 30 N/25 mm	DIN EN 1939

## Shranjevanje

Izdelek je treba zaščititi pred neposredno sončno svetlobo in shranjevati pri temperaturi od 10 °C do 30 °C. Zvitke je treba hraniti v suhem in pokončnem položaju. Izdelek ni občutljiv na zmrzal. Lastnosti strešne membrane ostanejo dolgo časa nespremenjene. Priporoča se obdelava v 12 mesecih.