

70342

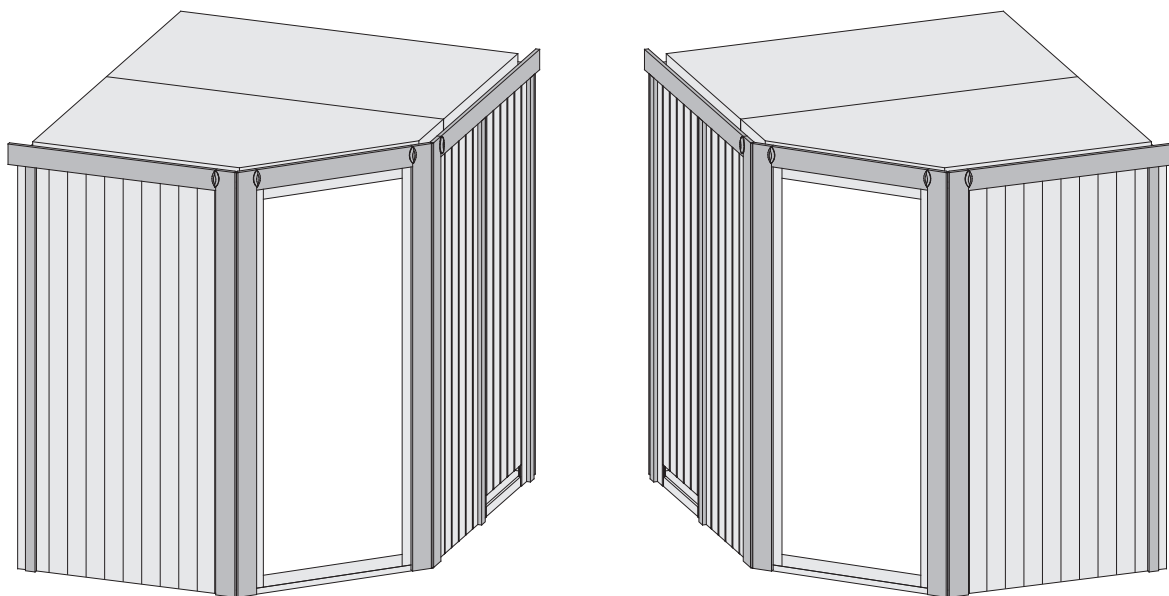

-  **Aufbauanleitung**
-  **Building Instructions**
-  **notice de montage**
-  **montagehandleiding**
-  **Montagevejledning**
-  **Instrucciones de construcción**
-  **Istruzioni per il montaggio**
-  **Montážní návod**
-  **Navodila za sestavljanje**

Bitte bewahren Sie die Anleitung und den Garantieschein zur Seriennummer auf.

Vernichten Sie diese erst nach Ablauf der Garantiezeit.

Eventuelle Beanstandungen können mithilfe der Stückliste einfacher zugeordnet werden.



Beigelegte Dokumente

- Informationsheft
- Garantieschein zur Seriennummer
- Typenschild inkl. Warnhinweise (Sauna)
- ggf. Zubehör-Anleitungen in externen Paketen

*

-  Nicht im Lieferumfang enthalten
-  Not included
-  Non comprises dans la livraison
-  Niet bijgeleverd
-  No forman parte del suministro
-  Non incluso
-  V ceně není zahrnuto
-  Ikke inkluderet
-  Ni vključeno v obseg dobave









2

-  Nicht gebraucht
-  Not needed
-  Pas nécessaire
-  Niet nodig
-  No es necesario
-  Non necessario
-  Není nutná
-  Ikke nødvendigt
-  Ne uporablja se

4

-  Fixiert vorübergehend
-  Fixed temporarily
-  Temporairement fixe
-  Tijdelijk vast
-  Temporalmente fijo
-  Temporaneamente fisso
-  Dočasně pevný
-  Midlertidigt rettet
-  Začasno popravi

1

-  Länge muss ermittelt und zugesägt werden
-  Length must be determined and sawn
-  La longueur doit être déterminée et sciée
-  De lengte moet worden bepaald en worden gezaagd
-  La longitud debe ser determinada y aserrada
-  La lunghezza deve essere determinata e segata
-  Délka musí být určena a rozřezána
-  Længden skal bestemmes og saves
-  Določiti je treba dolžino in jo odrezati po velikosti.

3

-  Mit Zubehör
-  With accessories
-  Avec accessoires
-  Met toebehoren
-  Con accesorios
-  Con accessori
-  S příslušenstvím
-  Med tilbehør
-  Z dodatki

5

-  Bestand vom Haus
-  Inventory of the house
-  Inventaire de la maison
-  Inventaris van het huis
-  Inventario de la casa
-  Inventario della casa
-  Inventář domu
-  Inventar af huset
-  Inventarizacija hiše

Technische Daten

In der Auftragsbestätigung bzw. Lieferschein ist der gekaufte Ofentyp bzw. das erworbene Steuergerät zu finden. Bitte entnehmen Sie die technischen Daten Ihrer Geräte der folgenden Auflistung

	Netzspannung	Wattage
Ofen		
9kW Bio	400V ~ 3N	9kW
9kW Finnisch	400V ~ 3N	9kW
9kW integr. Steuerung	400V ~ 3N	9kW
4,5kW Bio	400V ~ 3N	4,5kW
4,5kW Finnisch	400V ~ 3N	4,5kW
4,5kW integr. Steuerung	400V ~ 3N	4,5kW
3,6kW Bio	230V ~ 1N	3,6kW
3,6kW Finnisch	230V ~ 1N	3,6kW
3,6kW integr. Steuerung	230V ~ 1N	3,6kW
Steuergerät		
externe Easy Bio	400V ~ 3N	max. 10,8kW
externe Plug&Play Bio	240V ~ 3N	max. 10,8kW
externe Finnisch	400V ~ 3N	max. 10,8kW
externe Plug&Play Finnisch	240V ~ 3N	max. 10,8kW
Multisteuergerät	400V ~ 3N	max. 10,5kW
externe Classic Bio	400V ~ 3N	max. 9kW
externe Classic Finnisch	400V ~ 3N	max. 9kW
externe Premium Bio	400V ~ 3N	max. 12kW
externe Premium Finnisch	400V ~ 3N	max. 9kW

Technical data

The type of oven or control unit purchased can be found in the order confirmation or delivery note. Please refer to the following list for the technical data of your units

	Mains voltage	Wattage
Oven		
9kW Bio	400V ~ 3N	9kW
9kW Finnisch	400V ~ 3N	9kW
9kW integrated Control unit	400V ~ 3N	9kW
4,5kW Bio	400V ~ 3N	4,5kW
4,5kW Finnisch	400V ~ 3N	4,5kW
4,5kW integrated Control unit	400V ~ 3N	4,5kW
3,6kW Bio	230V ~ 1N	3,6kW
3,6kW Finnisch	230V ~ 1N	3,6kW
3,6kW integrated Control unit	230V ~ 1N	3,6kW
Control unit		
External Easy Bio	400V ~ 3N	max. 10,8kW
External Plug&Play Bio	240V ~ 3N	max. 10,8kW
External Finnisch	400V ~ 3N	max. 10,8kW
External Plug&Play Finnisch	240V ~ 3N	max. 10,8kW
Multi-controller	400V ~ 3N	max. 10,5kW
External Classic Bio	400V ~ 3N	max. 9kW
External Classic Finnisch	400V ~ 3N	max. 9kW
External Premium Bio	400V ~ 3N	max. 12kW
External Premium Finnisch	400V ~ 3N	max. 9kW

Données techniques

Dans la confirmation de commande ou le bon de livraison, vous trouverez le type de four ou l'appareil de commande que vous avez acheté. Veuillez consulter les données techniques de vos appareils dans la liste suivante

	Tension du réseau	Wattage
Four		
9kW Bio	400V ~ 3N	9kW
9kW Finnisch	400V ~ 3N	9kW
9kW intégré Unité de contrôle	400V ~ 3N	9kW
4,5kW Bio	400V ~ 3N	4,5kW
4,5kW Finnisch	400V ~ 3N	4,5kW
4,5kW intégré Unité de contrôle	400V ~ 3N	4,5kW
3,6kW Bio	230V ~ 1N	3,6kW
3,6kW Finnisch	230V ~ 1N	3,6kW
3,6kW intégré Unité de contrôle	230V ~ 1N	3,6kW
Unité de contrôle		
Externe Easy Bio	400V ~ 3N	max. 10,8kW
Externe Plug&Play Bio	240V ~ 3N	max. 10,8kW
Externe Finnisch	400V ~ 3N	max. 10,8kW
Externe Plug&Play Finnisch	240V ~ 3N	max. 10,8kW
Appareil de commande multiple	400V ~ 3N	max. 10,5kW
Externe Classic Bio	400V ~ 3N	max. 9kW
Externe Classic Finnisch	400V ~ 3N	max. 9kW
Externe Premium Bio	400V ~ 3N	max. 12kW
Externe Premium Finnisch	400V ~ 3N	max. 9kW

Technische gegevens

Het type oven of besturingseenheid dat u hebt gekocht, vindt u in de orderbevestiging of leveringsbon. Raadpleeg de volgende lijst voor de technische gegevens van uw apparaten

	Netspanning	Wattage
Oven		
9kW Bio	400V ~ 3N	9kW
9kW Finnisch	400V ~ 3N	9kW
9kW geïntegreerd Besturingseenheid	400V ~ 3N	9kW
4,5kW Bio	400V ~ 3N	4,5kW
4,5kW Finnisch	400V ~ 3N	4,5kW
4,5kW geïntegreerd Besturingseenheid	400V ~ 3N	4,5kW
3,6kW Bio	230V ~ 1N	3,6kW
3,6kW Finnisch	230V ~ 1N	3,6kW
3,6kW geïntegreerd Besturingseenheid	230V ~ 1N	3,6kW
Besturingseenheid		
Extern Easy Bio	400V ~ 3N	max. 10,8kW
Extern Plug&Play Bio	240V ~ 3N	max. 10,8kW
Extern Finnisch	400V ~ 3N	max. 10,8kW
Extern Plug&Play Finnisch	240V ~ 3N	max. 10,8kW
Multi-controller	400V ~ 3N	max. 10,5kW
Extern Classic Bio	400V ~ 3N	max. 9kW
Extern Classic Finnisch	400V ~ 3N	max. 9kW
Extern Premium Bio	400V ~ 3N	max. 12kW
Extern Premium Finnisch	400V ~ 3N	max. 9kW

Tekniske data

Hvilken type ovn eller styreenhed, du har købt, fremgår af ordrebekræftelsen eller følgesedlen. Se venligst følgende liste for de tekniske data for dine enheder

	Netspænding	Wattforbrug
Ovn		
9kW Bio	400V ~ 3N	9kW
9kW Finnisch	400V ~ 3N	9kW
9kW integreret Kontrolenhed	400V ~ 3N	9kW
4,5kW Bio	400V ~ 3N	4,5kW
4,5kW Finnisch	400V ~ 3N	4,5kW
4,5kW integreret Kontrolenhed	400V ~ 3N	4,5kW
3,6kW Bio	230V ~ 1N	3,6kW
3,6kW Finnisch	230V ~ 1N	3,6kW
3,6kW integreret Kontrolenhed	230V ~ 1N	3,6kW
Kontrolenhed		
Ekstern Easy Bio	400V ~ 3N	max. 10,8kW
Ekstern Plug&Play Bio	240V ~ 3N	max. 10,8kW
Ekstern Finnisch	400V ~ 3N	max. 10,8kW
Ekstern Plug&Play Finnisch	240V ~ 3N	max. 10,8kW
Multi-controller	400V ~ 3N	max. 10,5kW
Ekstern Classic Bio	400V ~ 3N	max. 9kW
Ekstern Classic Finnisch	400V ~ 3N	max. 9kW
Ekstern Premium Bio	400V ~ 3N	max. 12kW
Ekstern Premium Finnisch	400V ~ 3N	max. 9kW

Datos técnicos

El tipo de horno o unidad de control adquirida figura en la confirmación del pedido o en el albarán de entrega. Consulte en la siguiente lista los datos técnicos de sus unidades.

	Tensión de red	Vatios
Horno		
9kW Bio	400V ~ 3N	9kW
9kW Finnisch	400V ~ 3N	9kW
9kW integrado Unidad de control	400V ~ 3N	9kW
4,5kW Bio	400V ~ 3N	4,5kW
4,5kW Finnisch	400V ~ 3N	4,5kW
4,5kW integrado Unidad de control	400V ~ 3N	4,5kW
3,6kW Bio	230V ~ 1N	3,6kW
3,6kW Finnisch	230V ~ 1N	3,6kW
3,6kW integrado Unidad de control	230V ~ 1N	3,6kW
Unidad de control		
Exterior Easy Bio	400V ~ 3N	max. 10,8kW
Exterior Plug&Play Bio	240V ~ 3N	max. 10,8kW
Exterior Finnisch	400V ~ 3N	max. 10,8kW
Exterior Plug&Play Finnisch	240V ~ 3N	max. 10,8kW
Mando múltiple	400V ~ 3N	max. 10,5kW
Exterior Classic Bio	400V ~ 3N	max. 9kW
Exterior Classic Finnisch	400V ~ 3N	max. 9kW
Exterior Premium Bio	400V ~ 3N	max. 12kW
Exterior Premium Finnisch	400V ~ 3N	max. 9kW

 **Dati tecnici**

Il tipo di forno o di unità di controllo acquistato è riportato nella conferma d'ordine o nella bolla di consegna. Per i dati tecnici delle unità, consultare il seguente elenco

	Tensione di rete	Potenza
Forno		
9kW Bio	400V ~ 3N	9kW
9kW Finnisch	400V ~ 3N	9kW
9kW integrato Unità di controllo	400V ~ 3N	9kW
4,5kW Bio	400V ~ 3N	4,5kW
4,5kW Finnisch	400V ~ 3N	4,5kW
4,5kW integrato Unità di controllo	400V ~ 3N	4,5kW
3,6kW Bio	230V ~ 1N	3,6kW
3,6kW Finnisch	230V ~ 1N	3,6kW
3,6kW integrato Unità di controllo	230V ~ 1N	3,6kW
Unità di controllo		
Esterno Easy Bio	400V ~ 3N	max. 10,8kW
Esterno Plug&Play Bio	240V ~ 3N	max. 10,8kW
Esterno Finnisch	400V ~ 3N	max. 10,8kW
Esterno Plug&Play Finnisch	240V ~ 3N	max. 10,8kW
Controllore multiplo	400V ~ 3N	max. 10,5kW
Esterno Classic Bio	400V ~ 3N	max. 9kW
Esterno Classic Finnisch	400V ~ 3N	max. 9kW
Esterno Premium Bio	400V ~ 3N	max. 12kW
Esterno Premium Finnisch	400V ~ 3N	max. 9kW

 **Technické údaje**

Typ zakoupené trouby nebo řídicí jednotky naleznete v potvrzení objednávky nebo v dodacím listu. Technické údaje vašich jednotek naleznete v následujícím seznamu

	Síťové napětí	Příkon
Trouba		
9kW Bio	400V ~ 3N	9kW
9kW Finnisch	400V ~ 3N	9kW
9kW integrovaný Řídicí jednotka	400V ~ 3N	9kW
4,5kW Bio	400V ~ 3N	4,5kW
4,5kW Finnisch	400V ~ 3N	4,5kW
4,5kW integrovaný Řídicí jednotka	400V ~ 3N	4,5kW
3,6kW Bio	230V ~ 1N	3,6kW
3,6kW Finnisch	230V ~ 1N	3,6kW
3,6kW integrovaný Řídicí jednotka	230V ~ 1N	3,6kW
Řídicí jednotka		
Externí Easy Bio	400V ~ 3N	max. 10,8kW
Externí Plug&Play Bio	240V ~ 3N	max. 10,8kW
Externí Finnisch	400V ~ 3N	max. 10,8kW
Externí Plug&Play Finnisch	240V ~ 3N	max. 10,8kW
Multi-controller	400V ~ 3N	max. 10,5kW
Externí Classic Bio	400V ~ 3N	max. 9kW
Externí Classic Finnisch	400V ~ 3N	max. 9kW
Externí Premium Bio	400V ~ 3N	max. 12kW
Externí Premium Finnisch	400V ~ 3N	max. 9kW

 **Tehnični podatki**

Vrsta kupljene pečice ali krmilne enote je navedena v potrditvi naročila ali dobavnici. Tehnične podatke vaših enot najdete na naslednjem seznamu

	Omrežna napetost	Moč
Pečica		
9kW Bio	400V ~ 3N	9kW
9kW Finnisch	400V ~ 3N	9kW
9kW integriran Nadzorna enota	400V ~ 3N	9kW
4,5kW Bio	400V ~ 3N	4,5kW
4,5kW Finnisch	400V ~ 3N	4,5kW
4,5kW integriran Nadzorna enota	400V ~ 3N	4,5kW
3,6kW Bio	230V ~ 1N	3,6kW
3,6kW Finnisch	230V ~ 1N	3,6kW
3,6kW integriran Nadzorna enota	230V ~ 1N	3,6kW
Nadzorna enota		
Zunanja stran Easy Bio	400V ~ 3N	max. 10,8kW
Zunanja stran Plug&Play Bio	240V ~ 3N	max. 10,8kW
Zunanja stran Finnisch	400V ~ 3N	max. 10,8kW
Zunanja stran Plug&Play Finnisch	240V ~ 3N	max. 10,8kW
Več krmilnikov	400V ~ 3N	max. 10,5kW
Zunanja stran Classic Bio	400V ~ 3N	max. 9kW
Zunanja stran Classic Finnisch	400V ~ 3N	max. 9kW
Zunanja stran Premium Bio	400V ~ 3N	max. 12kW
Zunanja stran Premium Finnisch	400V ~ 3N	max. 9kW

 Vergleichen Sie zuerst die Material-liste mit Ihrem Paketinhalt! Bitte haben Sie Verständnis, dass Beanstandungen nur im nicht aufgebauten Zustand bearbeitet werden können!

 First compare the list of materials with your package contents! Please understand that complaints can be processed in the non-built status only!

 Commencez par comparer la liste du matériel avec le contenu de votre paquet! Sachez que nous traitons uniquement les réclamations concernant le matériel à l'état non monté!

 Vergelijk eerst de lijst van materialen met de inhoud van uw pakket! Reclamaties kunnen alleen in behandeling worden genomen zolang de onderdelen nog niet zijn gemonteerd!

 Start med at kontrollere materialelisten med indholdet af den leverede pakke! Vi gør venligst opmærksom på at reklamationer kun kan behandles for materialer som ikke er blevet bearbejdet!

 En primer lugar, compare la lista de material con el contenido del paquete. Rogamos entienda que las reclamaciones sólo pueden ser tramitadas antes de montar el objeto!

 Confrontate questa distinta materiali prima con il contenuto del pacchetto! Vi preghiamo di comprendere che eventuali reclami possono essere accolti solo prima del montaggio!

 Nejprve překontrolujte obsah balení podle materiálového listu! Mějte pochopení pro to, že případnou reklamaci se můžeme zabývat pouze tehdy, když díly nebudou smontované! Za pomoci tohoto seznamu můžete jednotlivé díly přiřadit k montážnímu návodu.

 Najprej primerajte seznam materialov z vsebino vašega paketa! Upoštevajte, da lahko pritožbe obravnavamo le v nesešavljenem stanju!

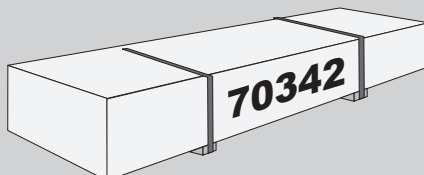

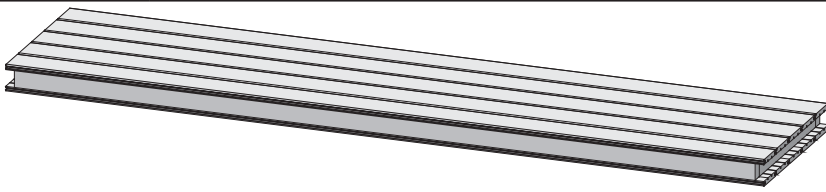
		
1 x W1	1920 x 606 x 68mm	ID 25548
1 x W2	1920 x 950 x 68mm	ID 24766

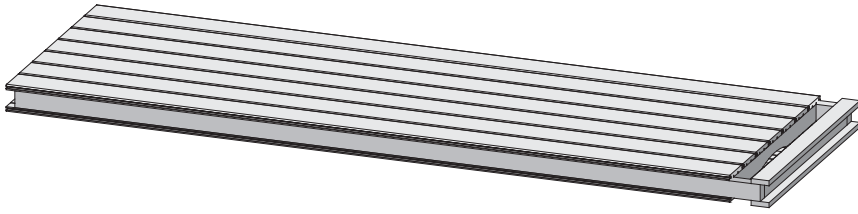
		
1 x W3	1920 x 606 x 68mm	ID 25550

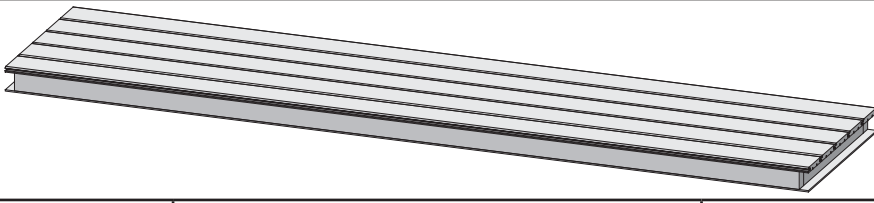
		
2 x W4	1920 x 606 x 57mm	ID 23624
2 x W5	1920 x 780 x 57mm	ID 23625

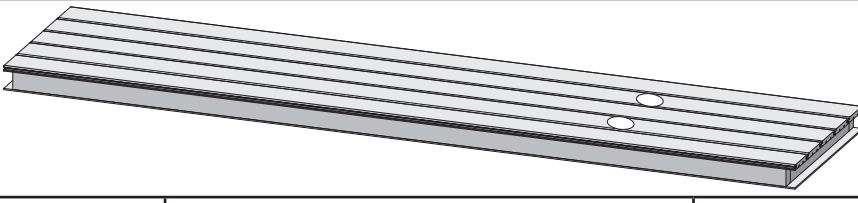
		
1 x W6	1920 x 606 x 57mm	ID 23629

 <div style="display: flex; justify-content: space-around;"> <div style="text-align: left;"> <p> Siehe Türpaket</p> <p> Opmerking Door Package</p> <p> Note Door Package</p> <p> Remarque Package porte</p> </div> <div style="text-align: left;"> <p> Nota Paquete Puerta</p> <p> Nota Door Package</p> <p> Poznámka Door balíček</p> <p> Poznámka Door balíček</p> </div> </div>		
1 x W7		

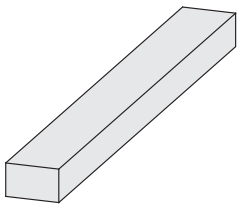

5 x B1	1920 x 19 x 3mm	ID 20799
3 x B2	1884 x 45 x 17mm	ID 48037
4 x B3	70 x 45 x 18mm	ID 26366
6 x B4	800 x 45 x 18mm	ID 24796
4 x B5	480 x 95 x 18mm	ID 20930
4 x B6	580 x 95 x 18mm	ID 16708
1 x B7	765 x 95 x 18mm	ID 26357
2 x B8	1227 x 95 x 18mm	ID 26379
1 x B9	300 x 120 x 18mm	ID 22467
2 x B10	590 x 42 x 28mm	ID 26360
2 x B11	1130 x 42 x 28mm	ID 26361
1 x B12	1555 x 42 x 28mm	ID 24130
2 x B13	1666 x 42 x 28mm	ID 26377
1 x B14	1759 x 42 x 28mm	ID 24133
2 x B15	1841 x 42 x 28mm	ID 26376
3 x B16	1874 x 52 x 52mm	ID 26165

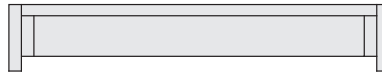

2 x L1	1810 x 550 x 90mm	ID 21767
--------	-------------------	----------

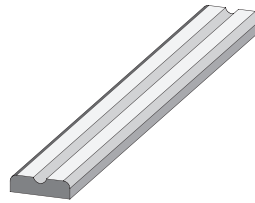

2 x L2	1810 x 90 x 22mm	ID 26112
--------	------------------	----------

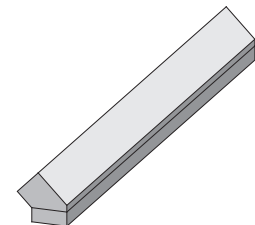

2 x K1	1874 x 76 x 38mm	ID 43464
--------	------------------	----------

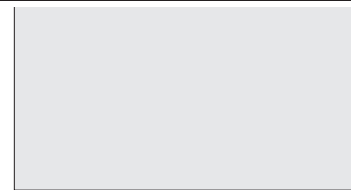

1 x M1	1582 x 918 x 57mm	ID 24795
--------	-------------------	----------

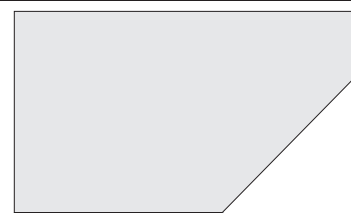

1 x M2	1582 x 918 x 68mm	ID 54141
--------	-------------------	----------

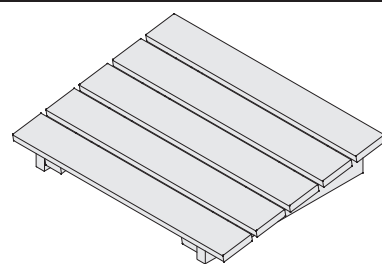

1 x		ID 99990
-----	--	----------

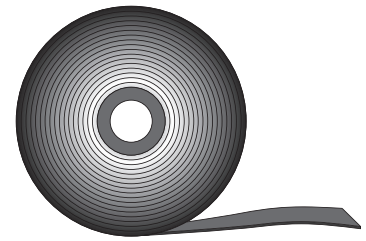

10m		ID 14025
-----	--	----------

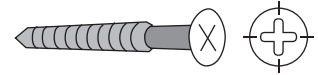

15 x	4 x 30mm	ID 3686
35 x	4 x 50mm	ID 3688
45 x	4 x 70mm	ID 3689
45 x	4,5 x 80mm	ID 9204
20 x	6 x 60mm	ID 14014

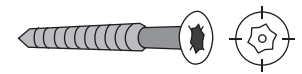

40 x	4,5 x 35mm	ID 62740
70 x	4,5 x 40mm	ID 26285

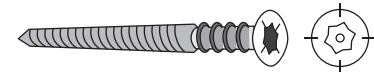

6 x S1		ID 14266
--------	--	----------



105 x S2	4,5 x 30mm	ID 26116
6 x S3	12 x 18mm	ID 46403

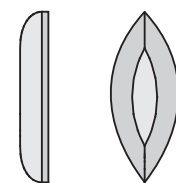

4 x T1		ID 26272
--------	--	----------

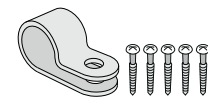

1 x		ID 60284
-----	--	----------

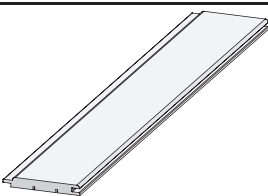
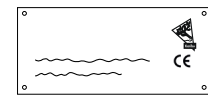

2 x E1	1920 x 97 x 12mm	ID 22863
--------	------------------	----------

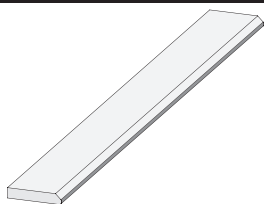

2 x G1	1884 x 58 x 17mm	ID 48521
4 x G2	1980 x 95 x 17mm	ID 48540

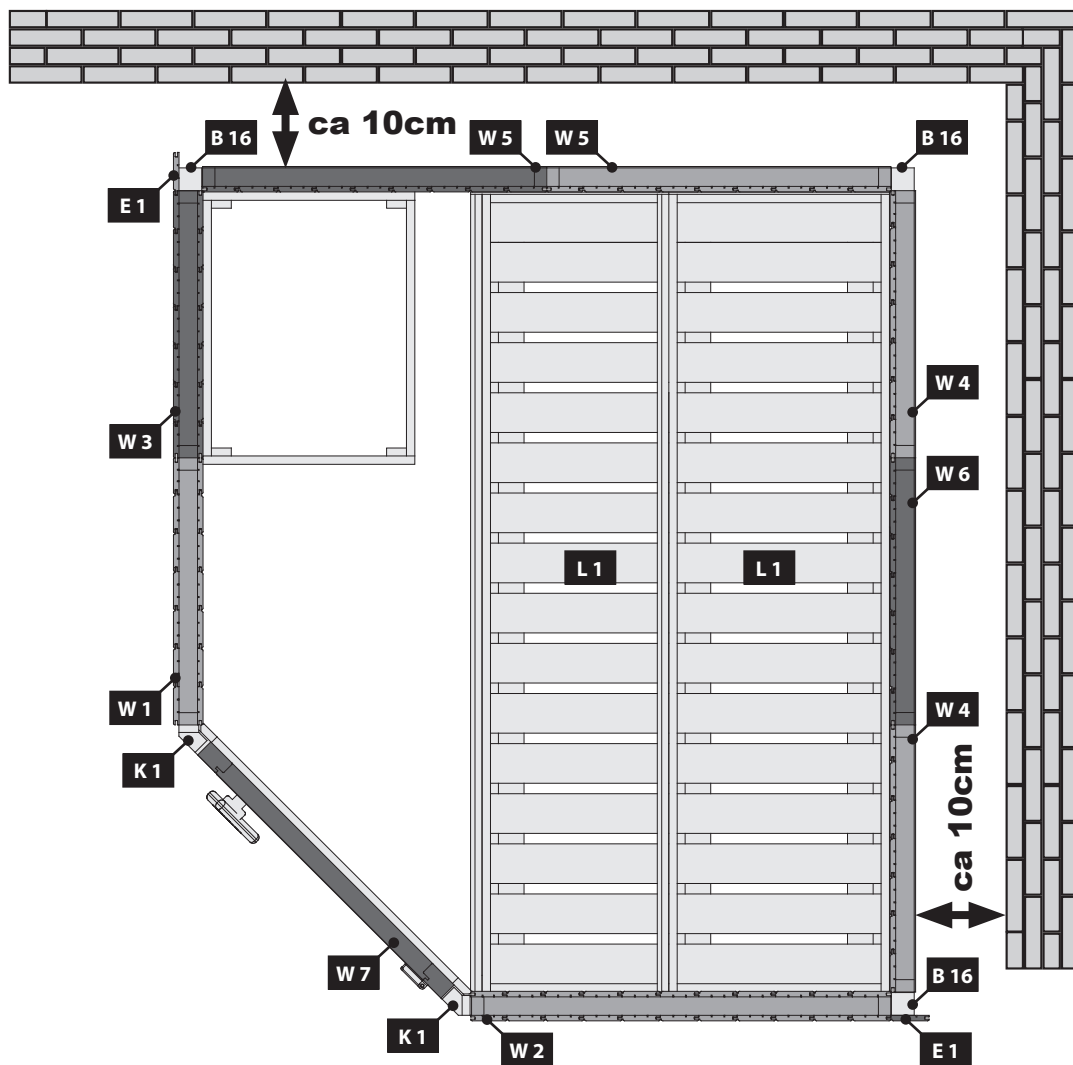
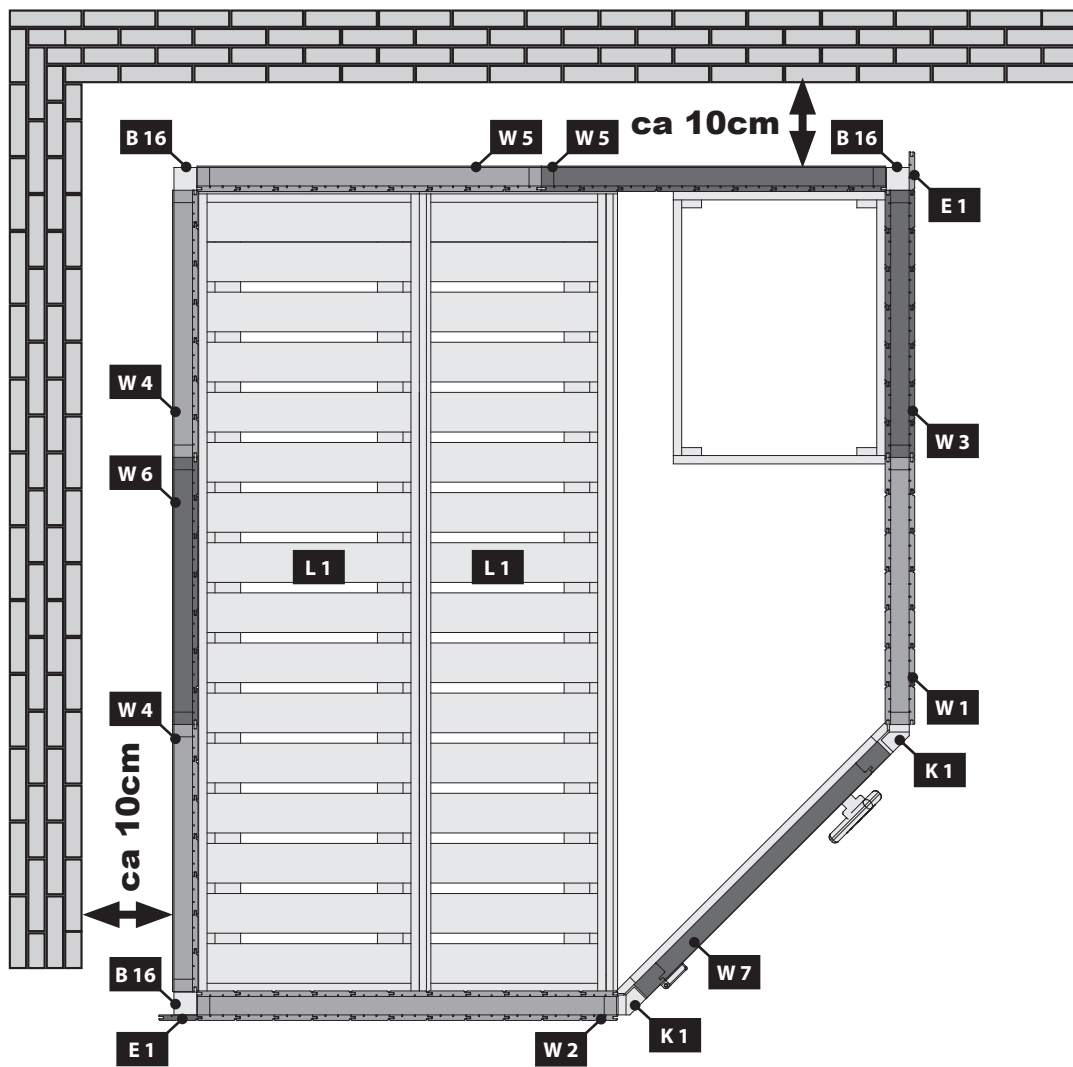

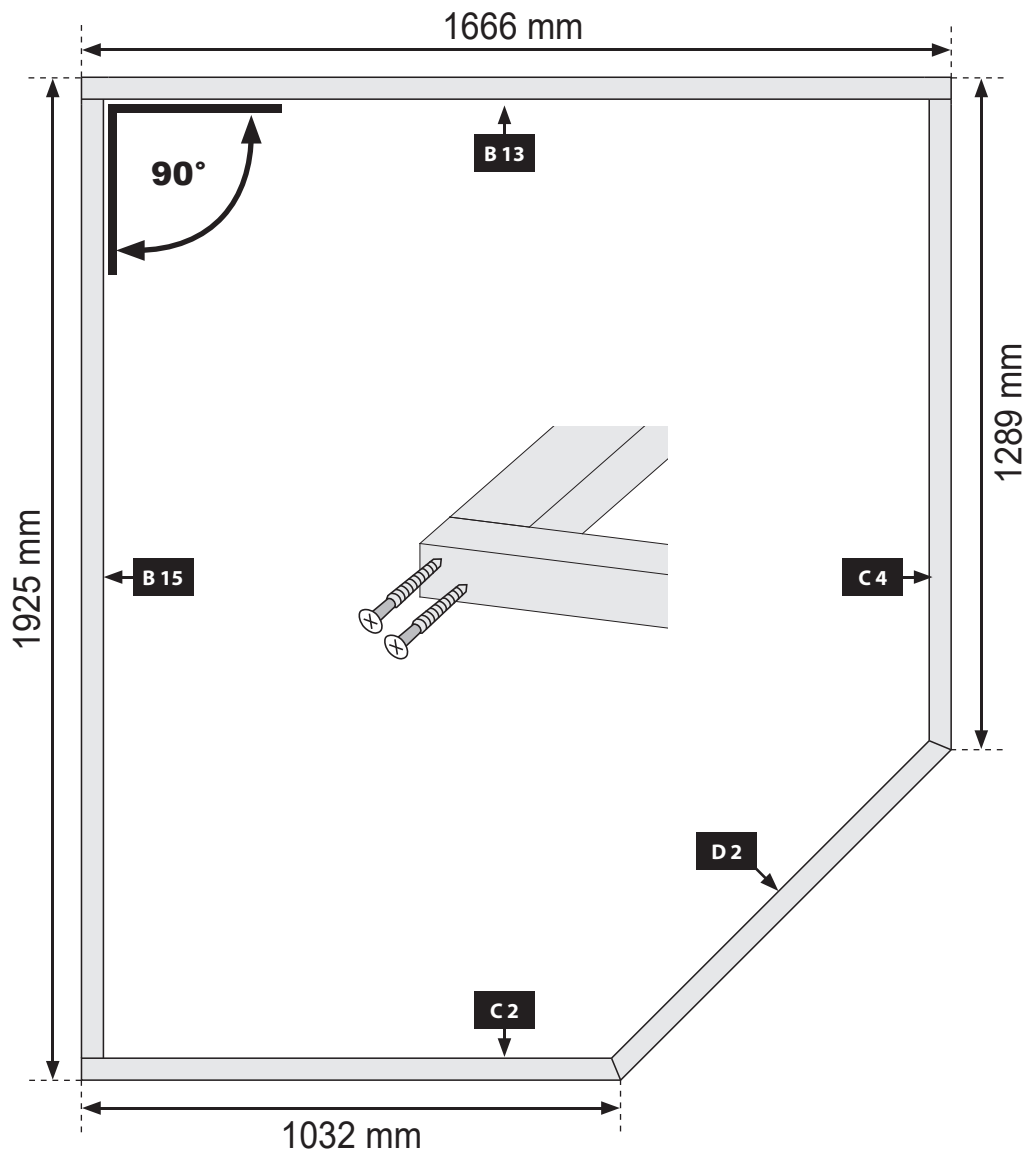
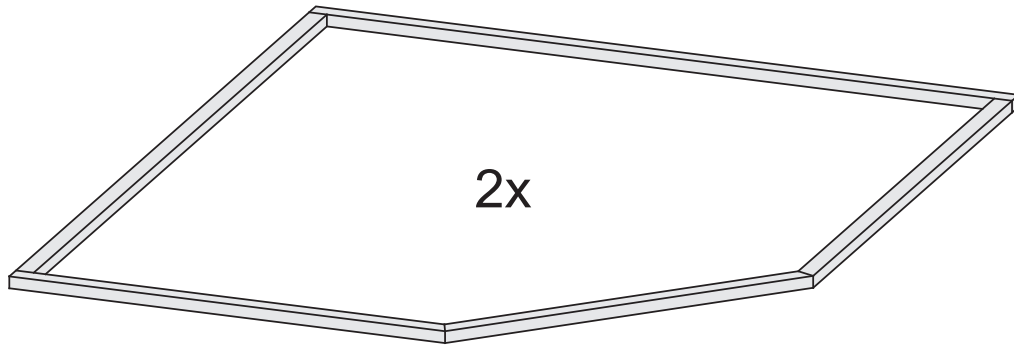
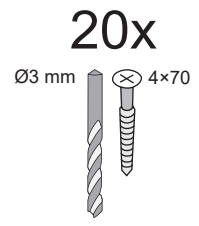
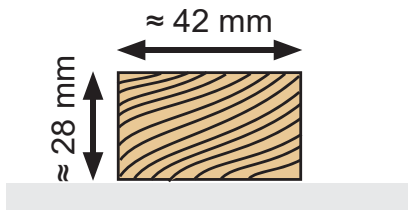

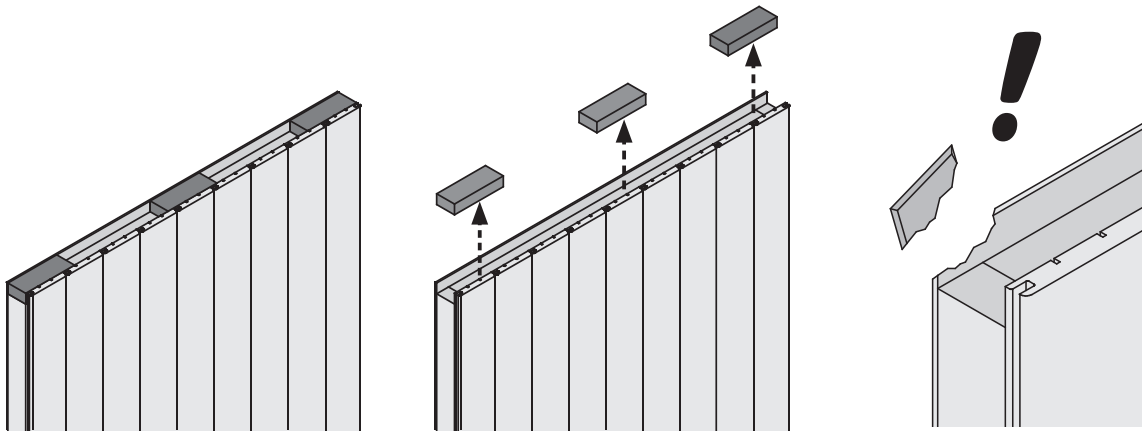

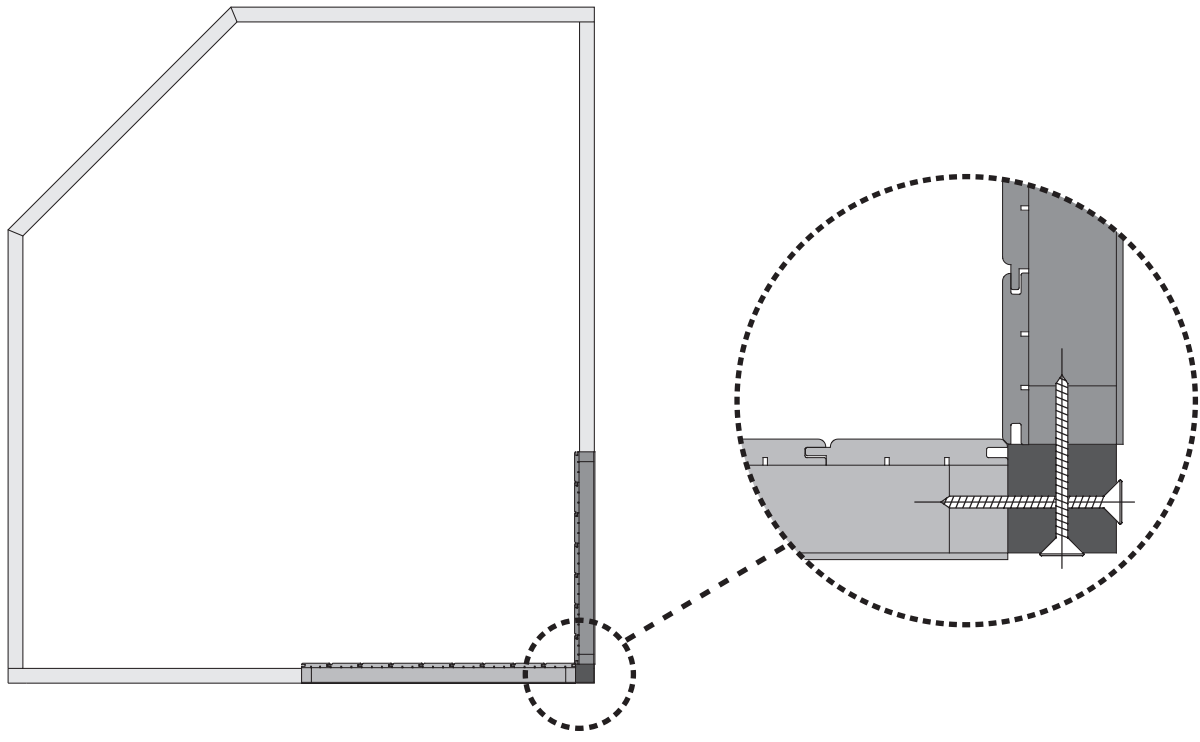

-  Vorsicht!
-  Attention!
-  Attention!
-  Voorzichtig!
-  Forsigtig!
-  Cuidado!
-  Occhio!
-  Pozor!

02



10x
 Ø4 mm  4,5x80 

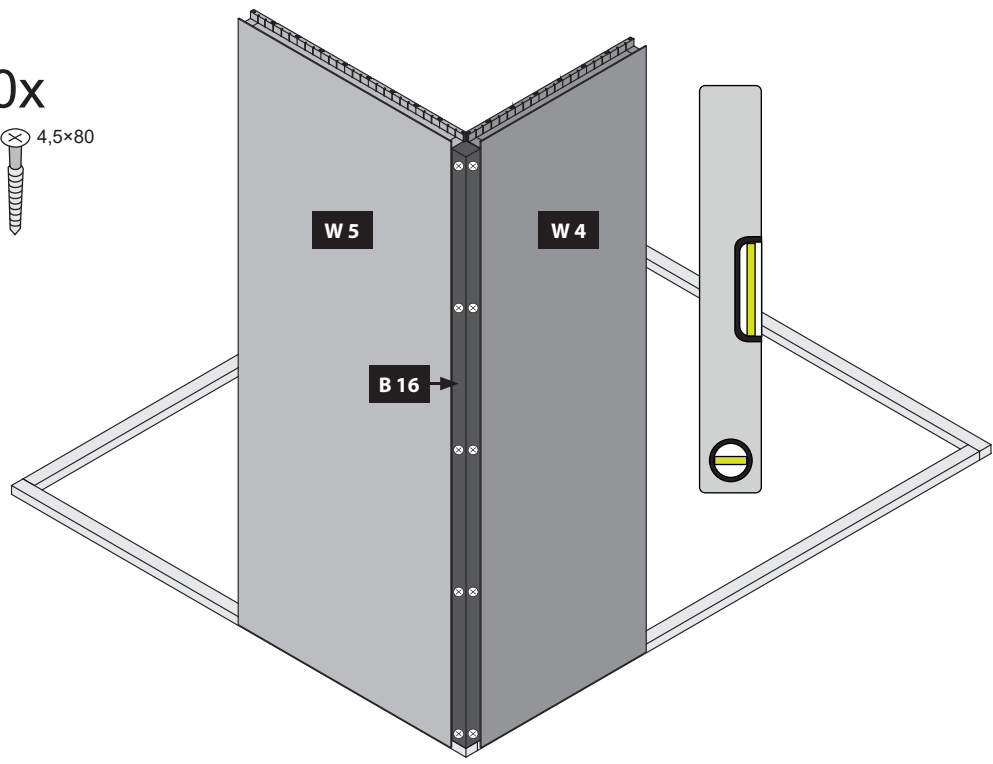

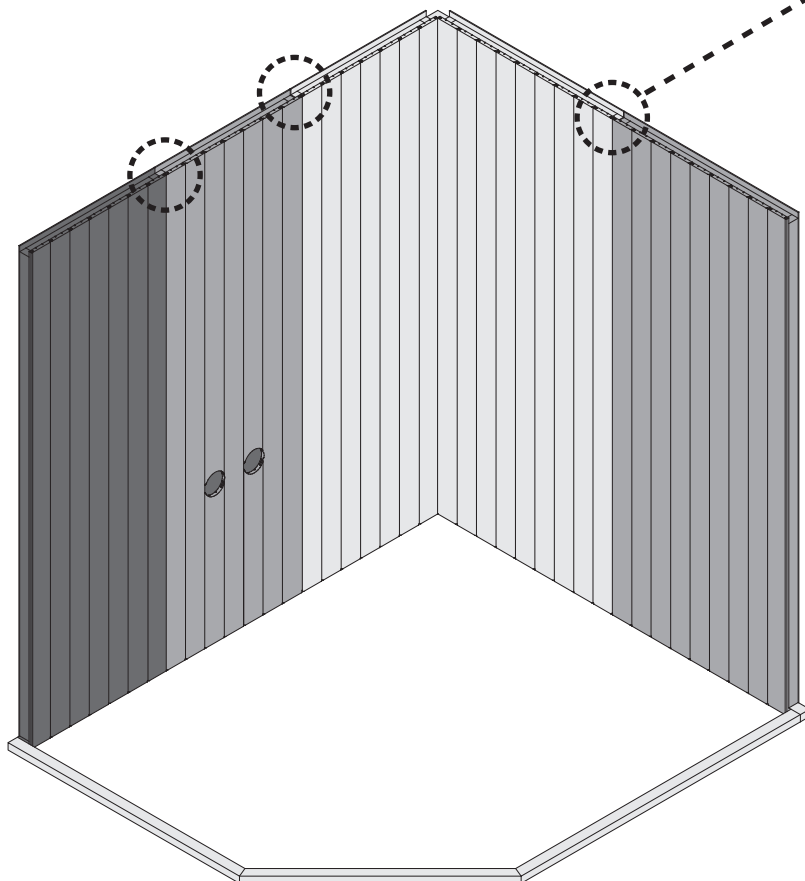
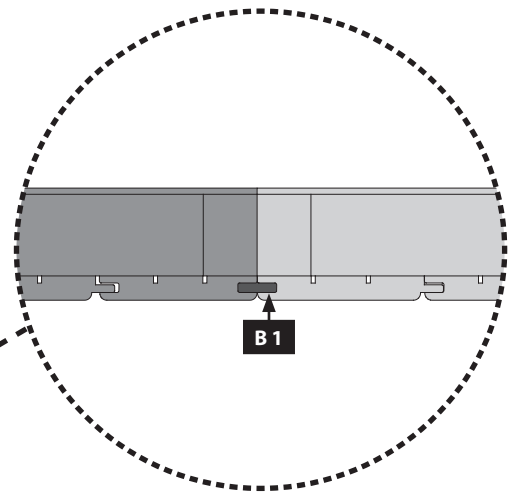
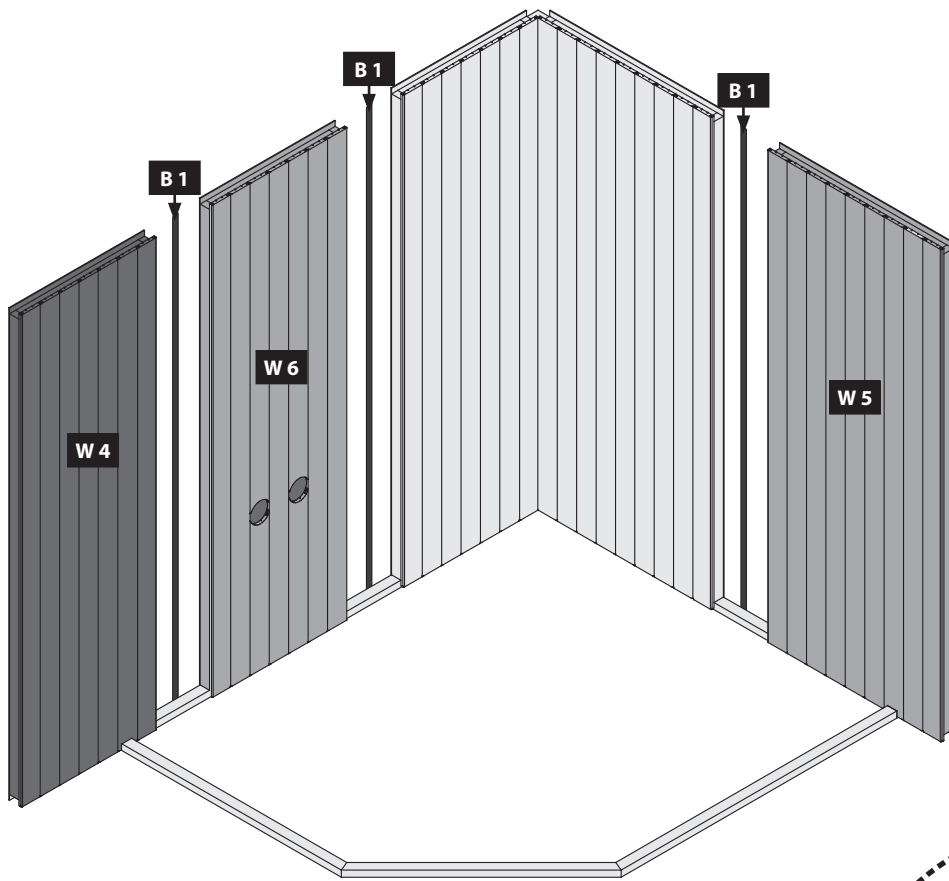

10x

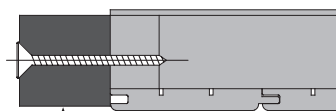
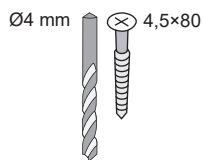

B 16

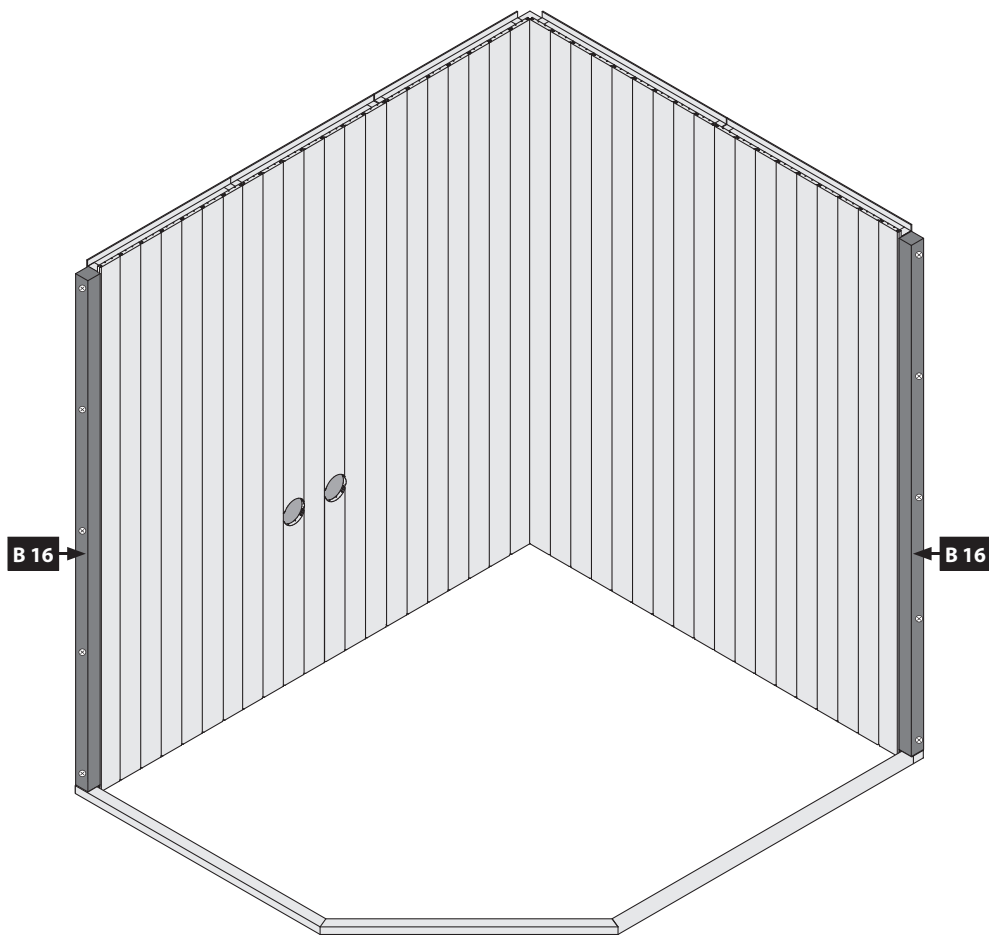

10x

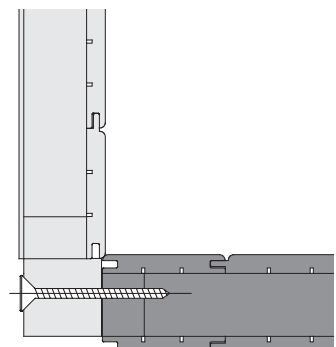
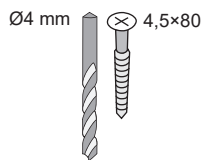

W 2

W 3

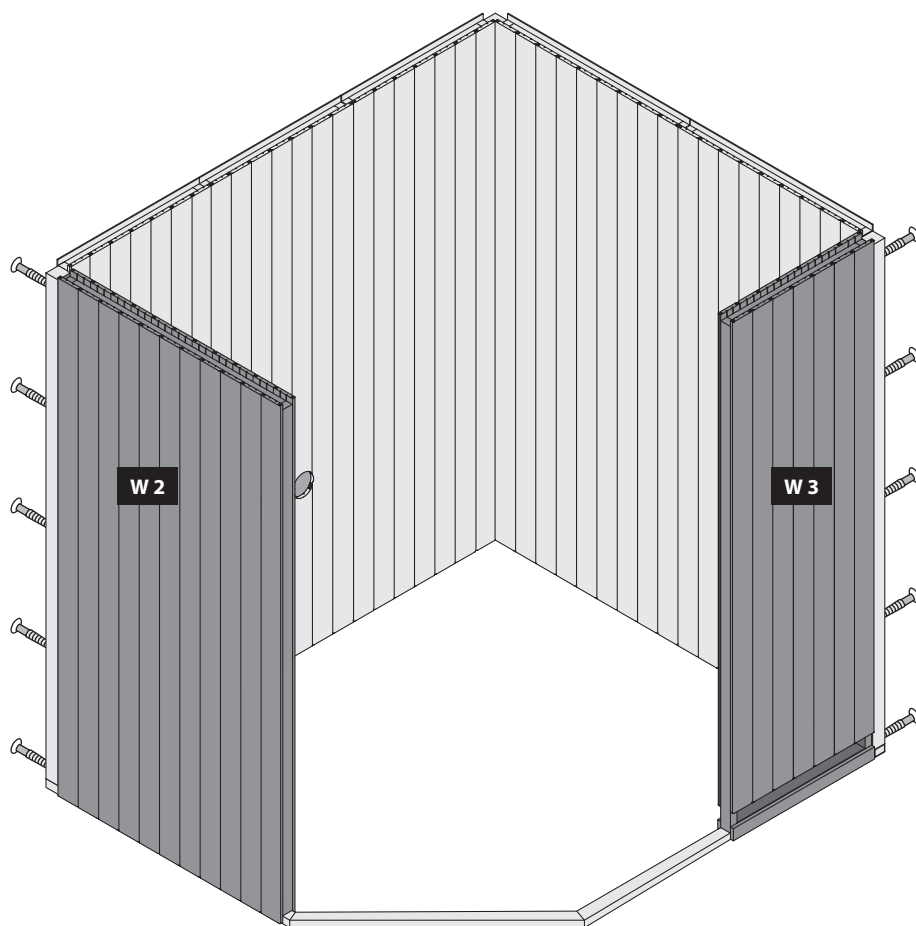

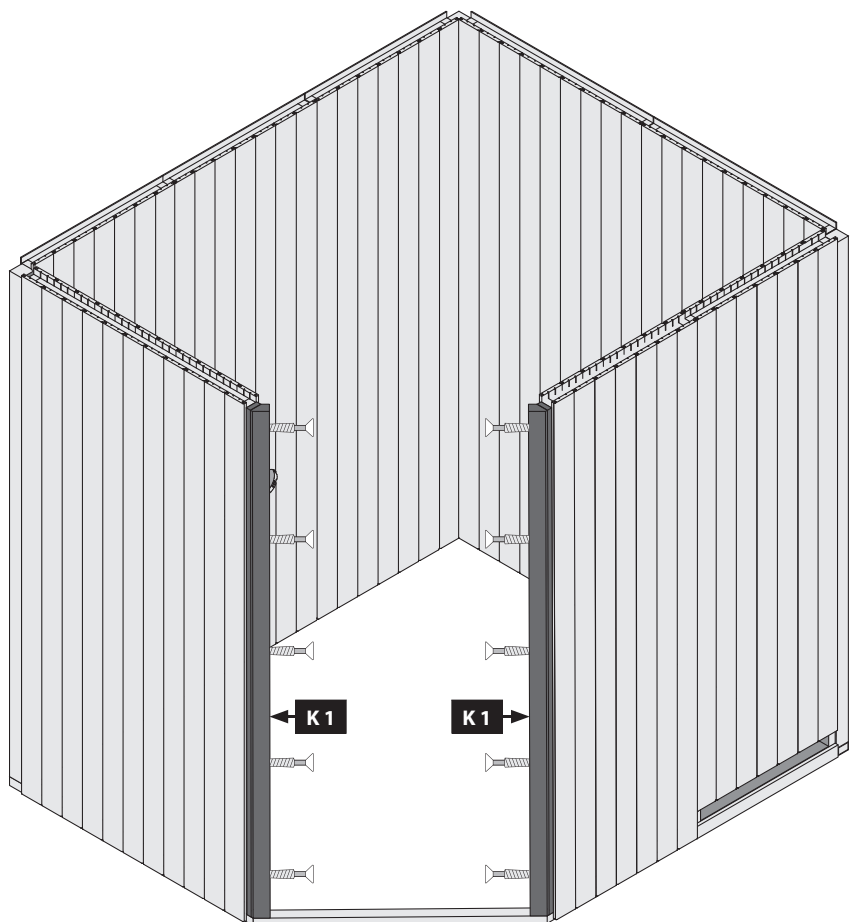
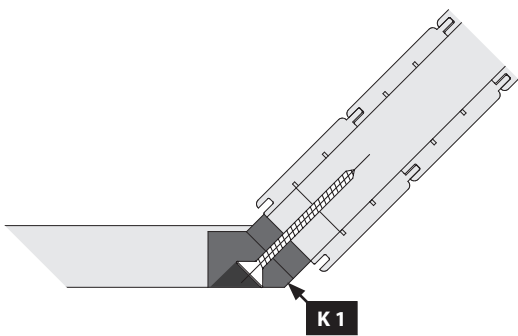
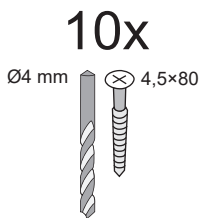
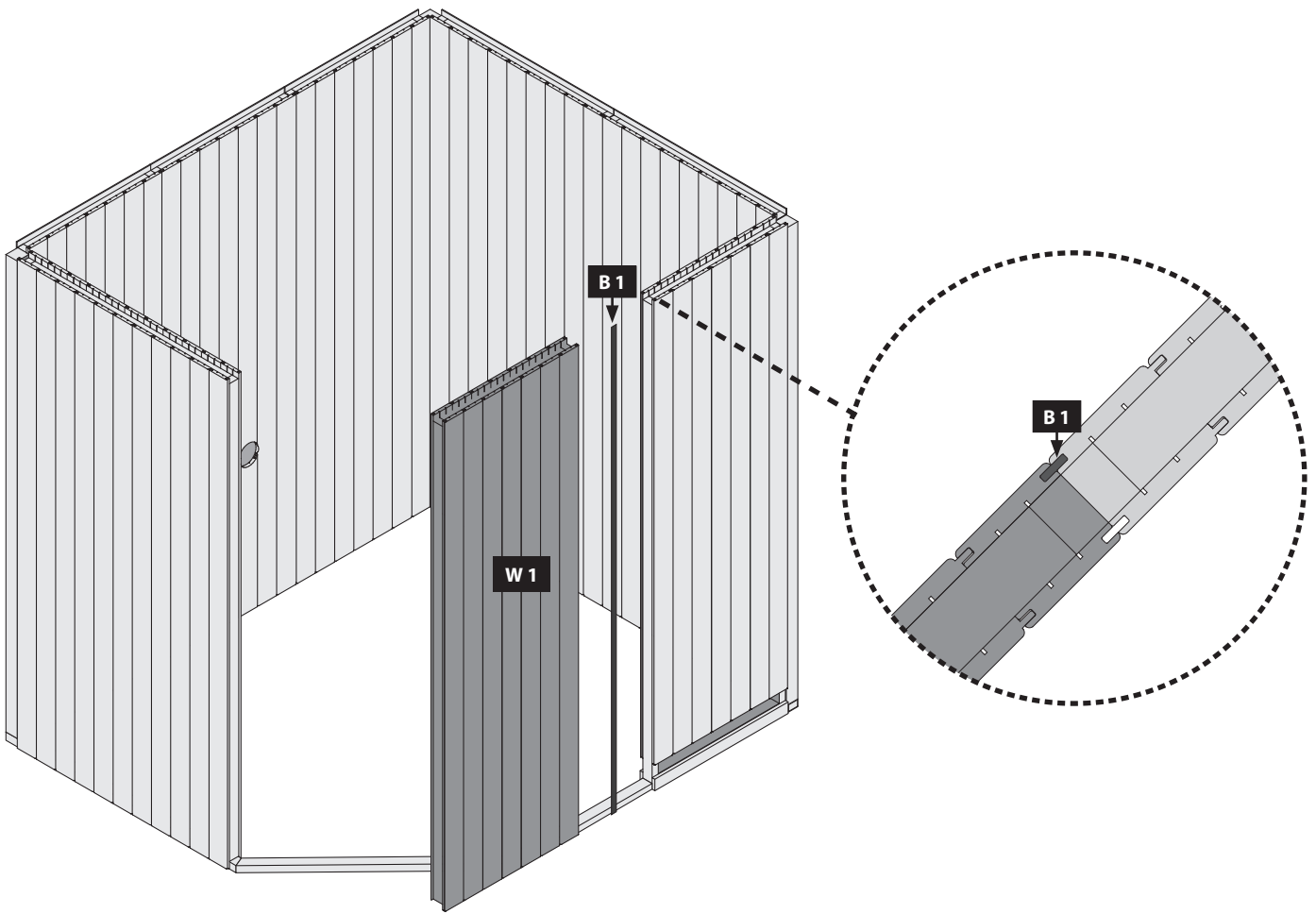

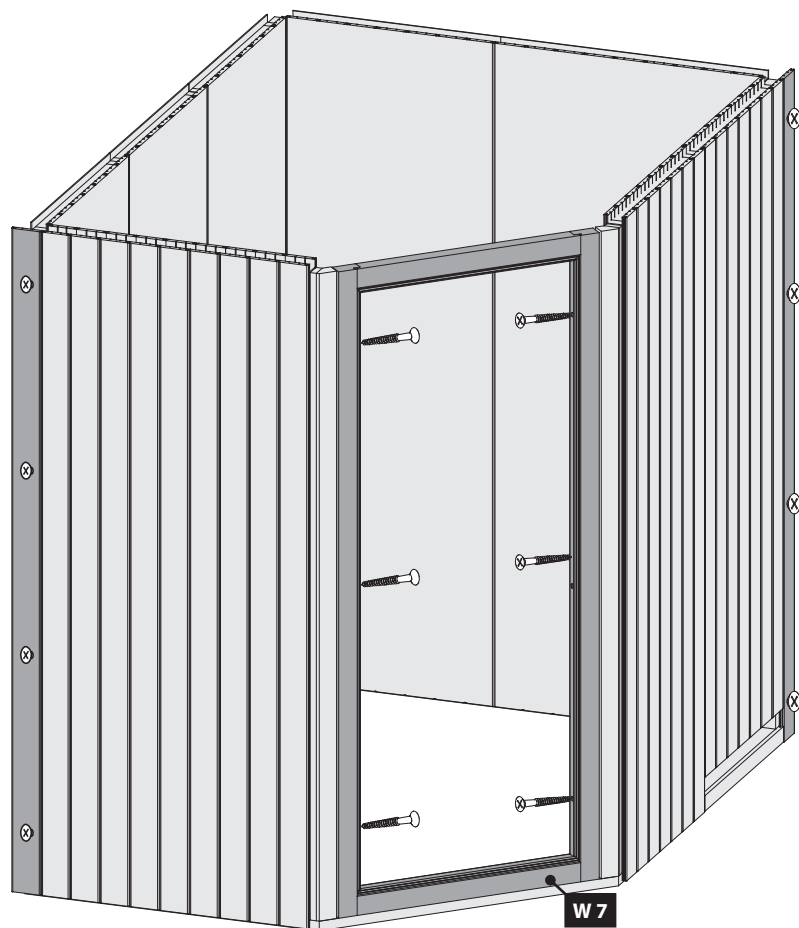

-  Einbau Tür
-  Installation door
-  Porte d'installation
-  Installatie deur
-  Installationsdør
-  Puerta de instalación
-  Porta di installazione
-  Montážní dveře
-  Vgradna vrata

!!! 01 — 03 **!!!**

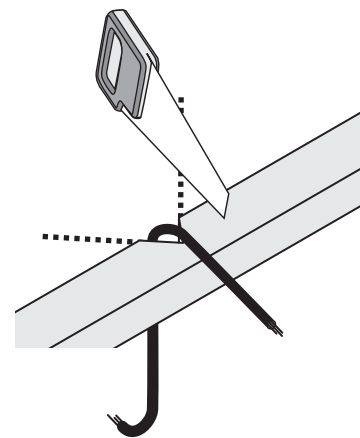
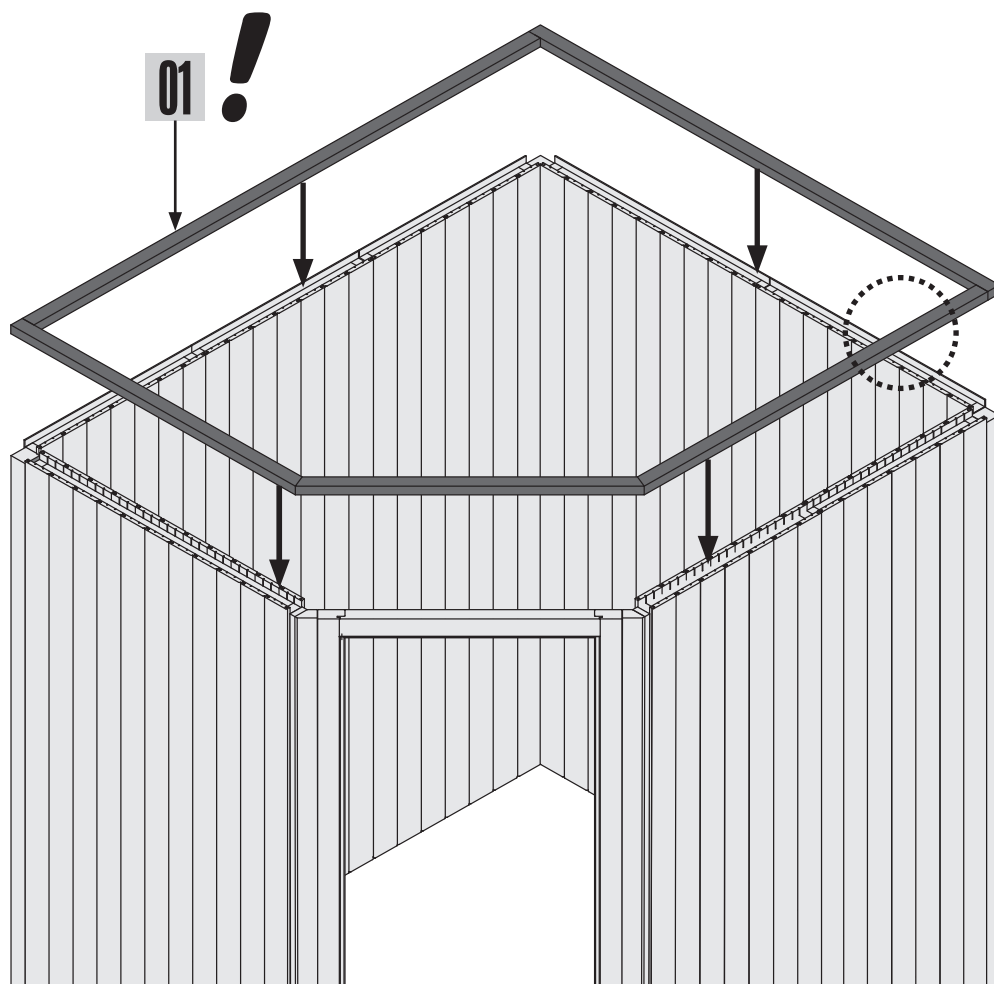

14x

Ø4 mm 4,5x40

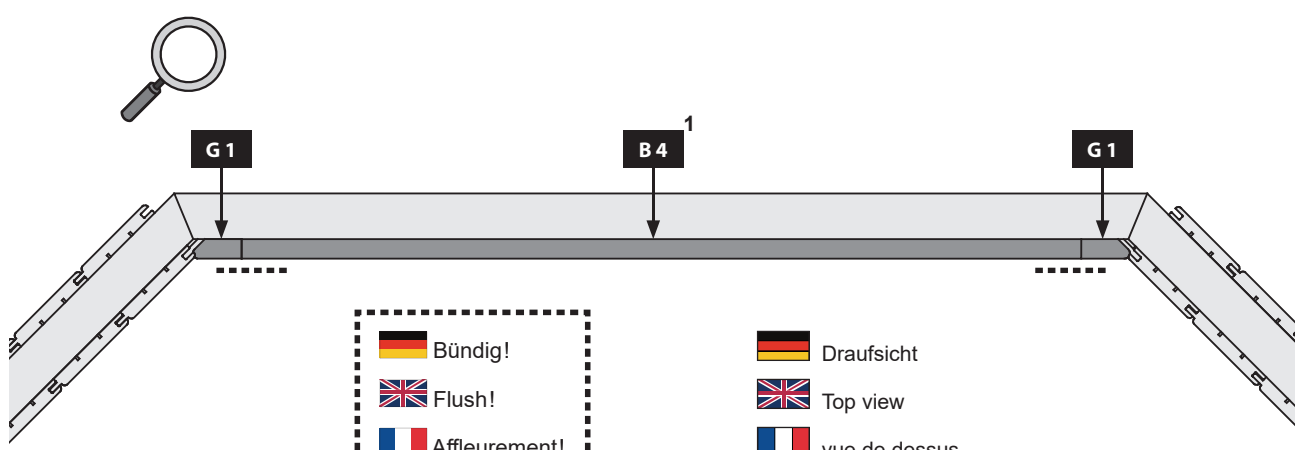
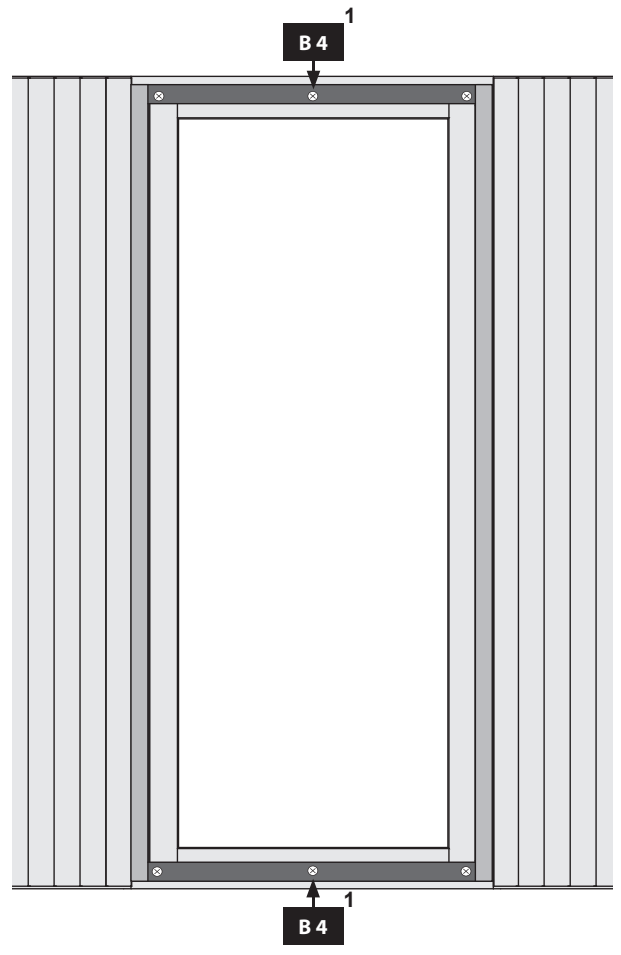
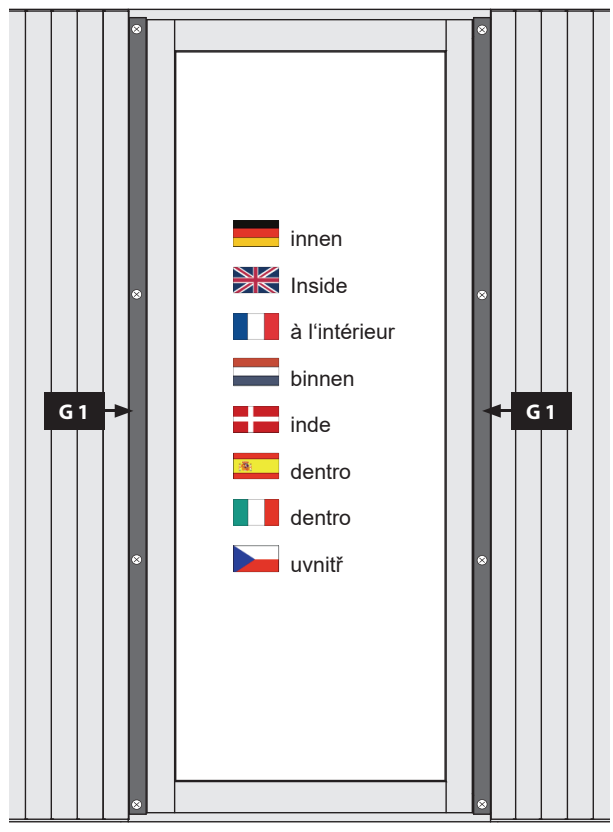
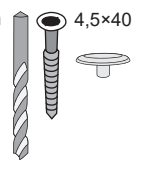

-  Bündig!
-  Flush!
-  Affleurement!
-  I flugt!
-  Gelijk!
-  Aras!
-  Combacia!
-  Stejný !

-  Draufsicht
-  Top view
-  vue de dessus
-  bovenaanzicht
-  vista desde arriba
-  vista desde arriba
-  vista dall'alto
-  půdorys

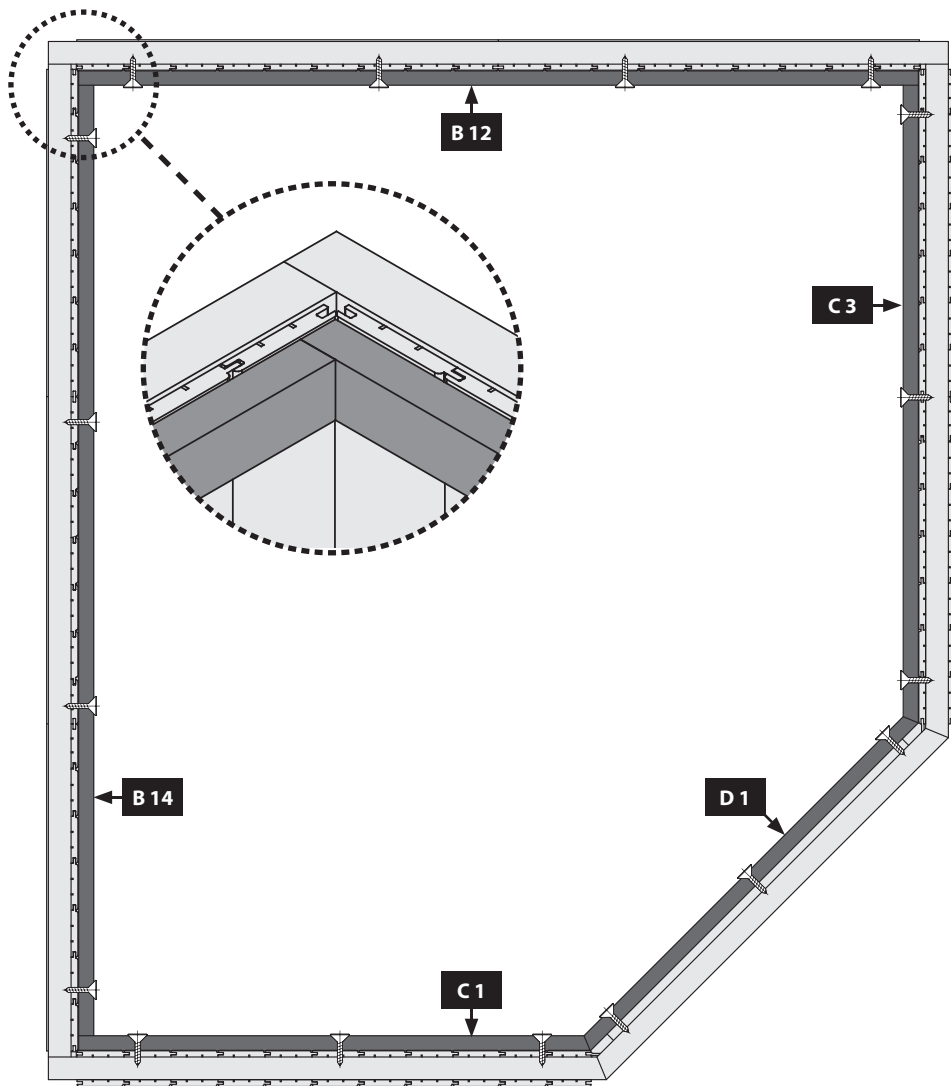

17x
 Ø3 mm 4x50

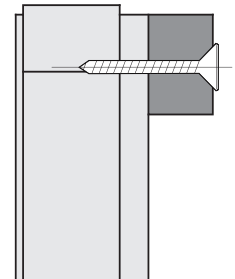

-  Draufsicht
-  Top view
-  vue de dessus
-  bovenaanzicht
-  vista desde arriba
-  vista desde arriba
-  vista dall'alto
-  púdorys

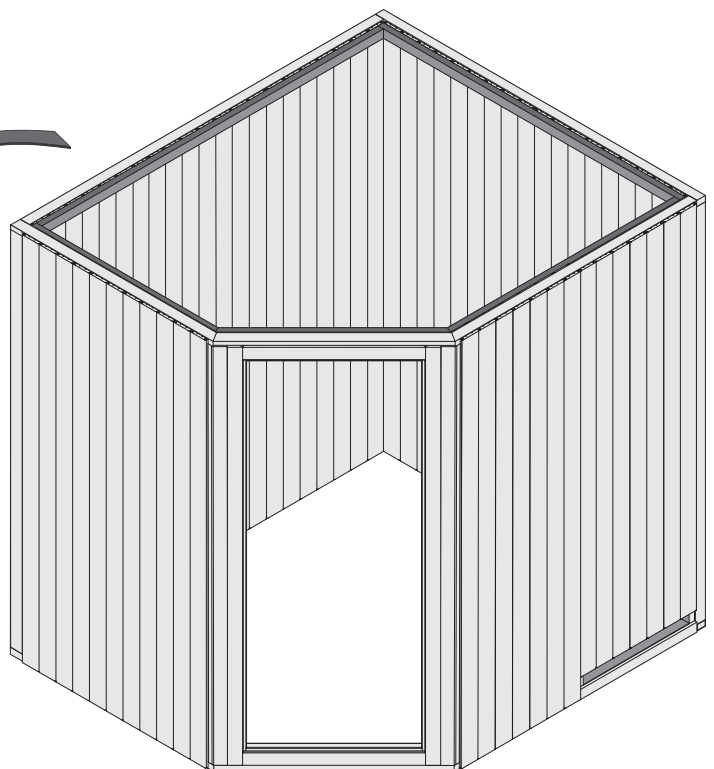
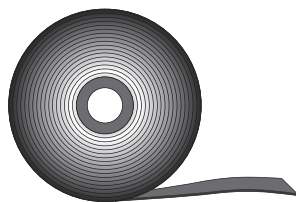
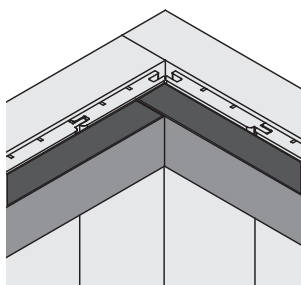

-  Sauna Dichtband
-  Sauna sealing tape
-  Ruban d'étanchéité pour sauna
-  Sauna tætningsbånd
-  Sauna afdichtingstape
-  Cinta de sellado de sauna
-  Nastro sigillante per sauna
-  Sauna těsnící páska

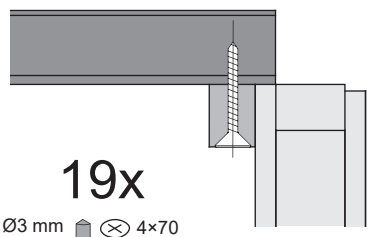
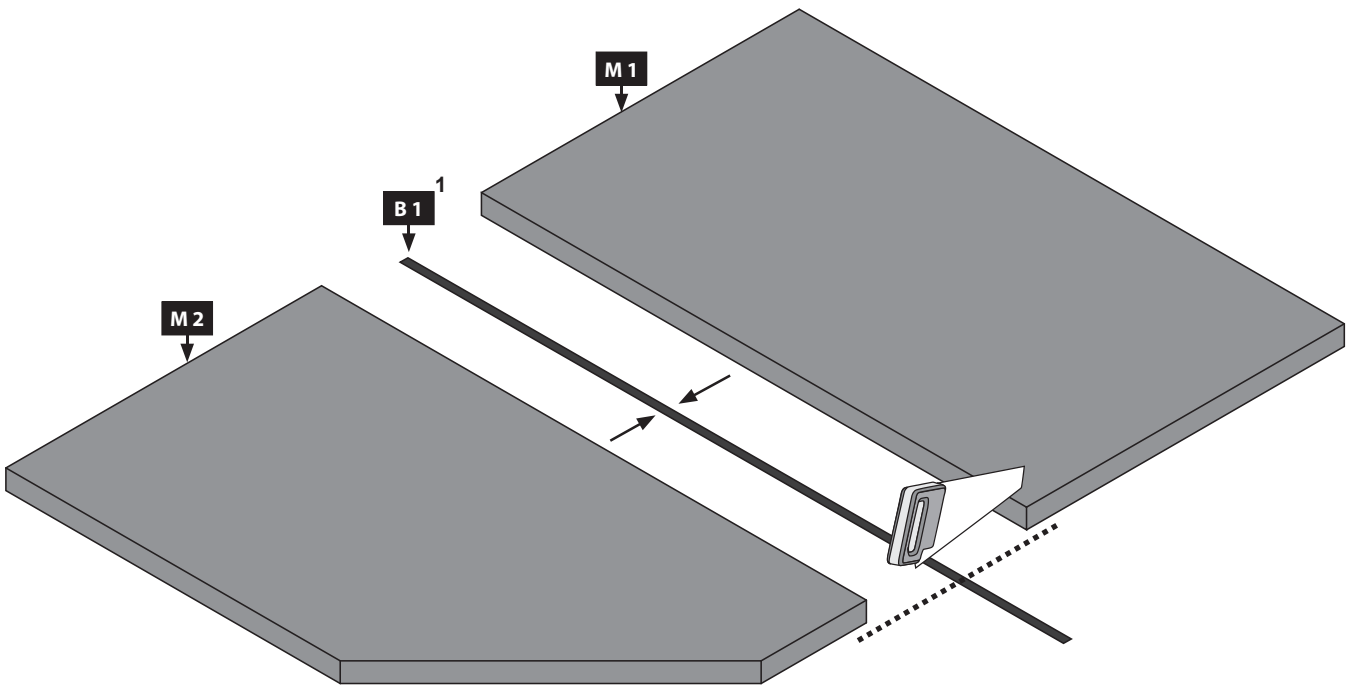

19x
Ø3 mm 4x70

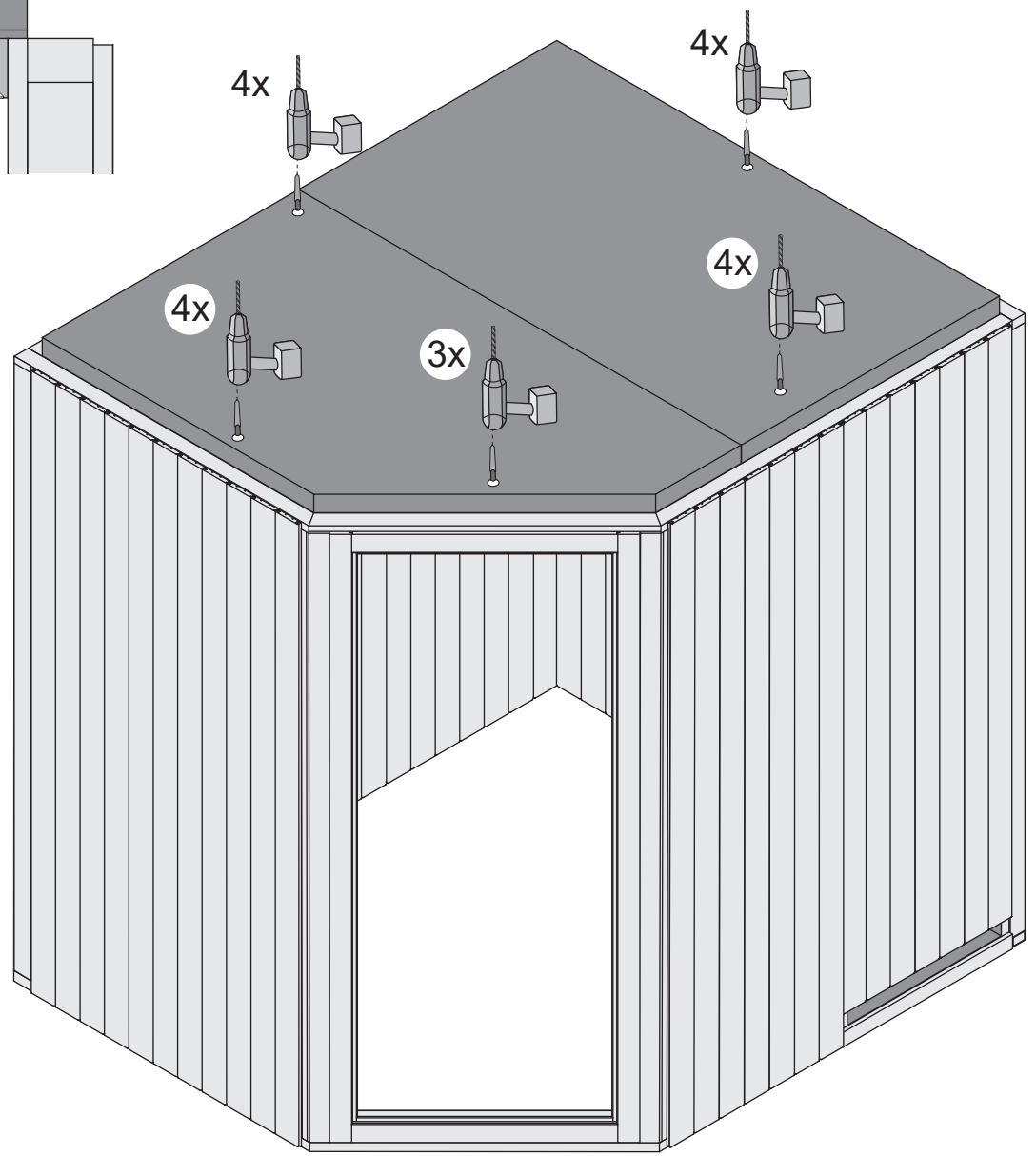
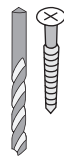

8x

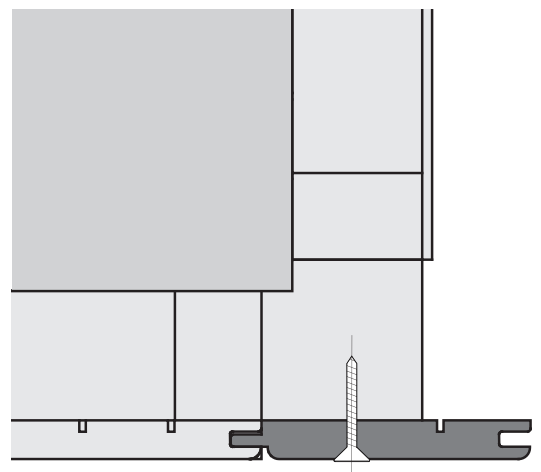
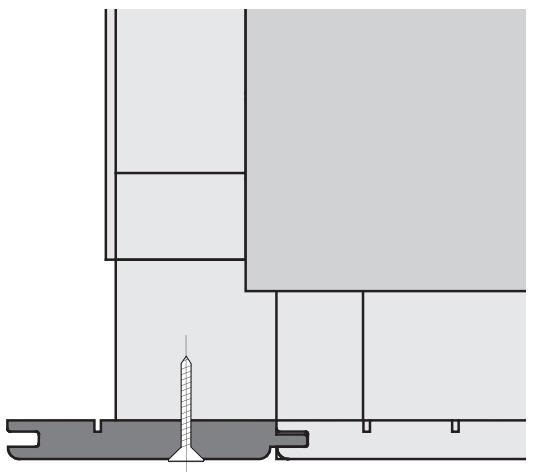
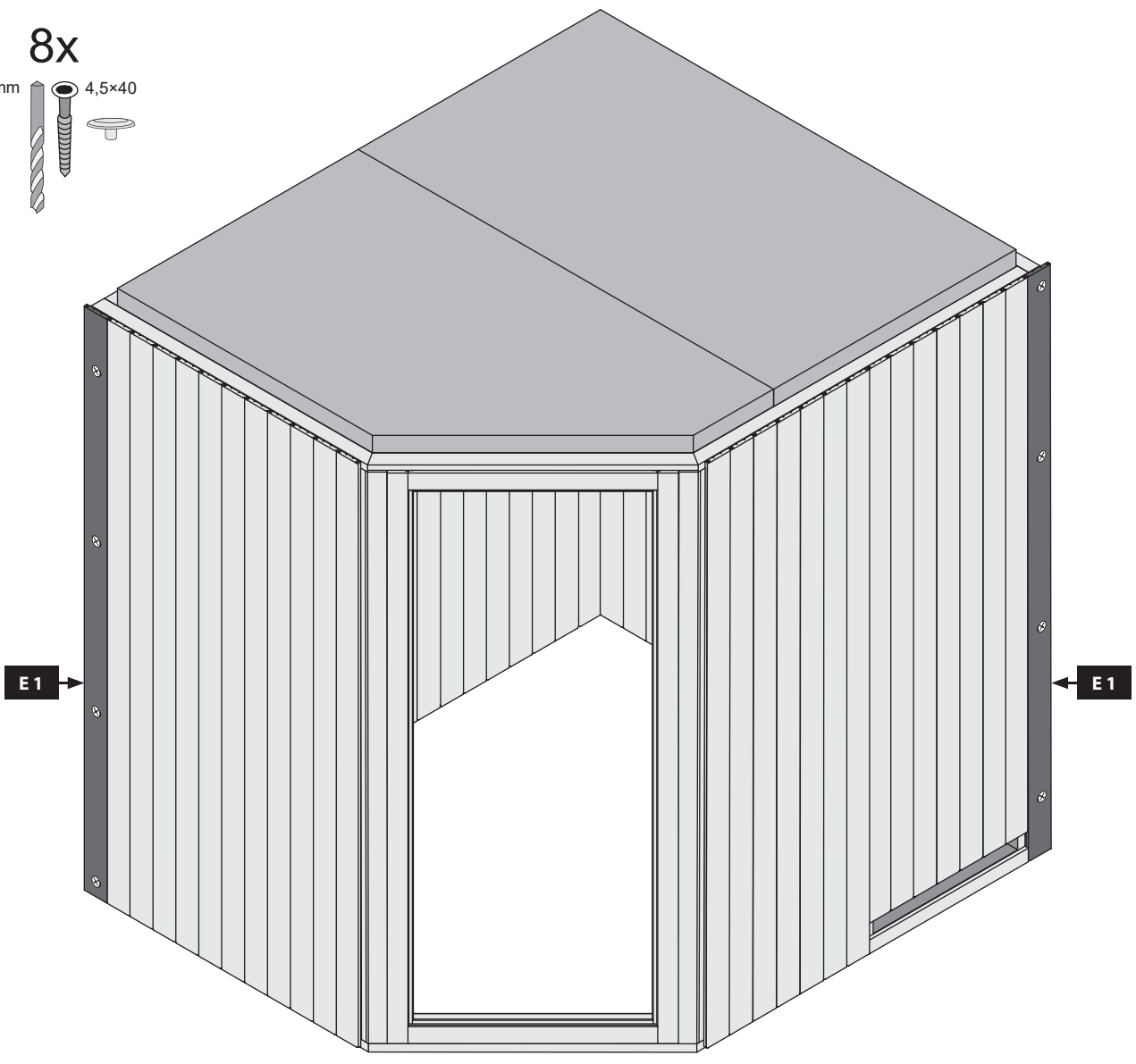
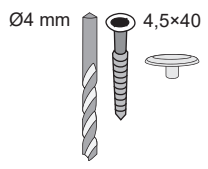

16x

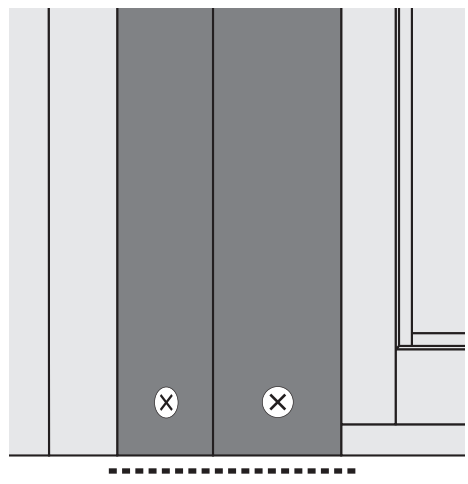
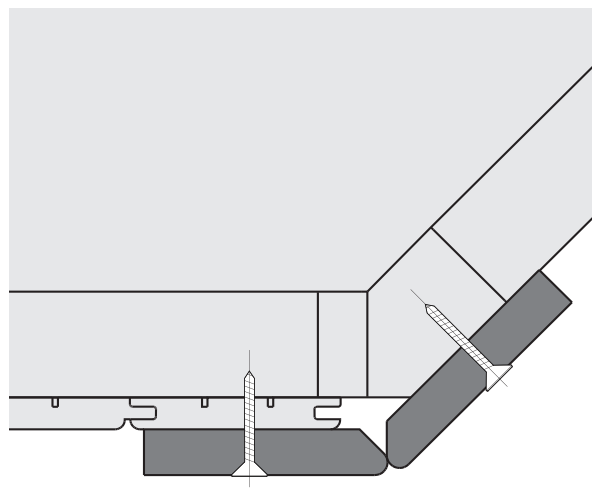
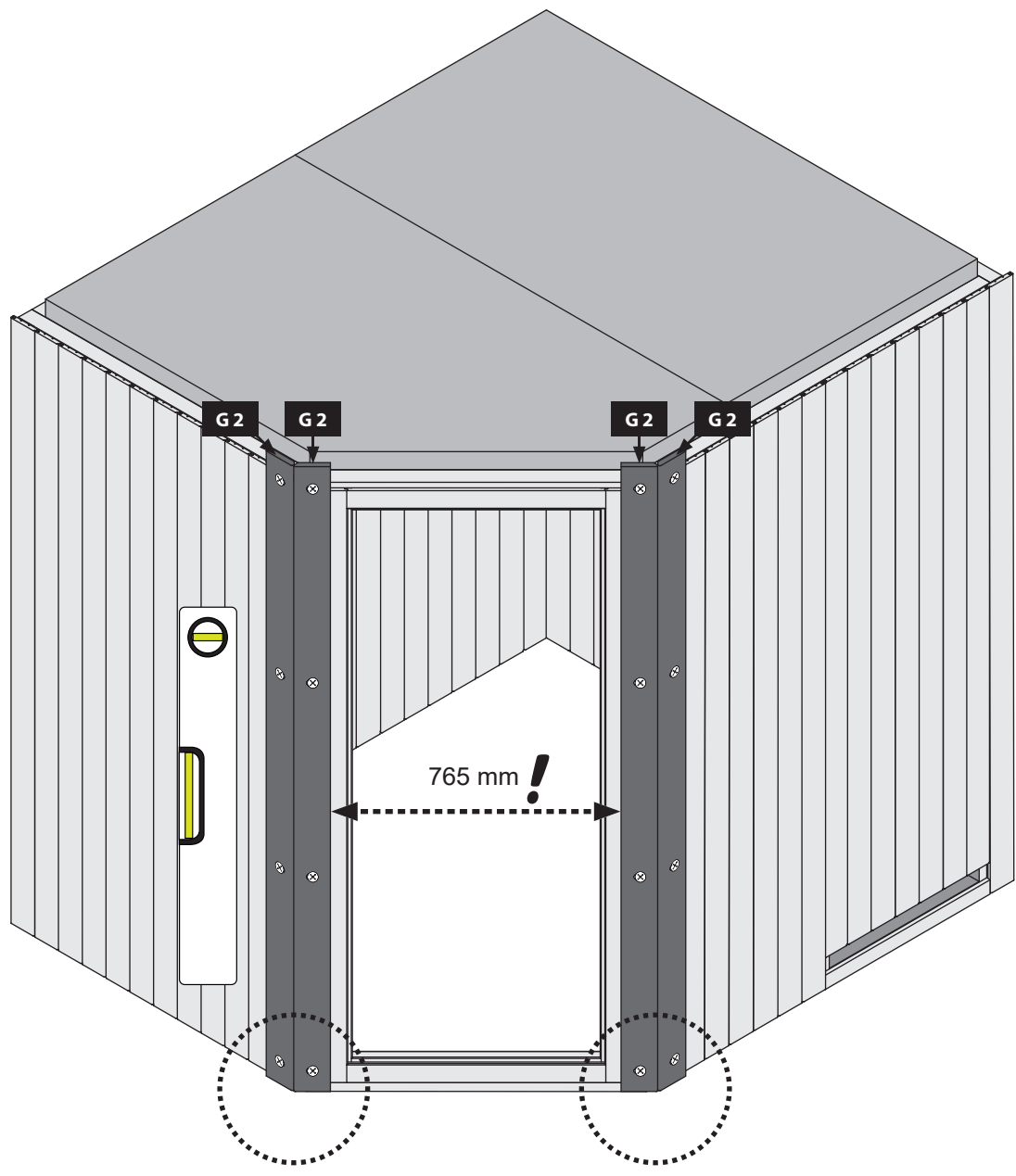
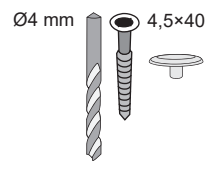

-  Bündig!
-  Flush!
-  Affleurement!
-  I flugt!
-  Gelijk!
-  Aras!
-  Combacia!
-  Stejný !

21x

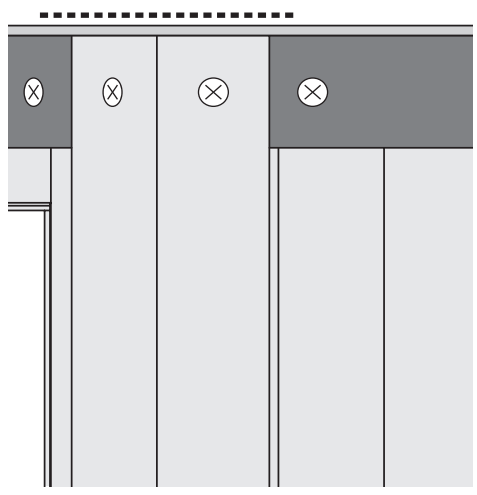
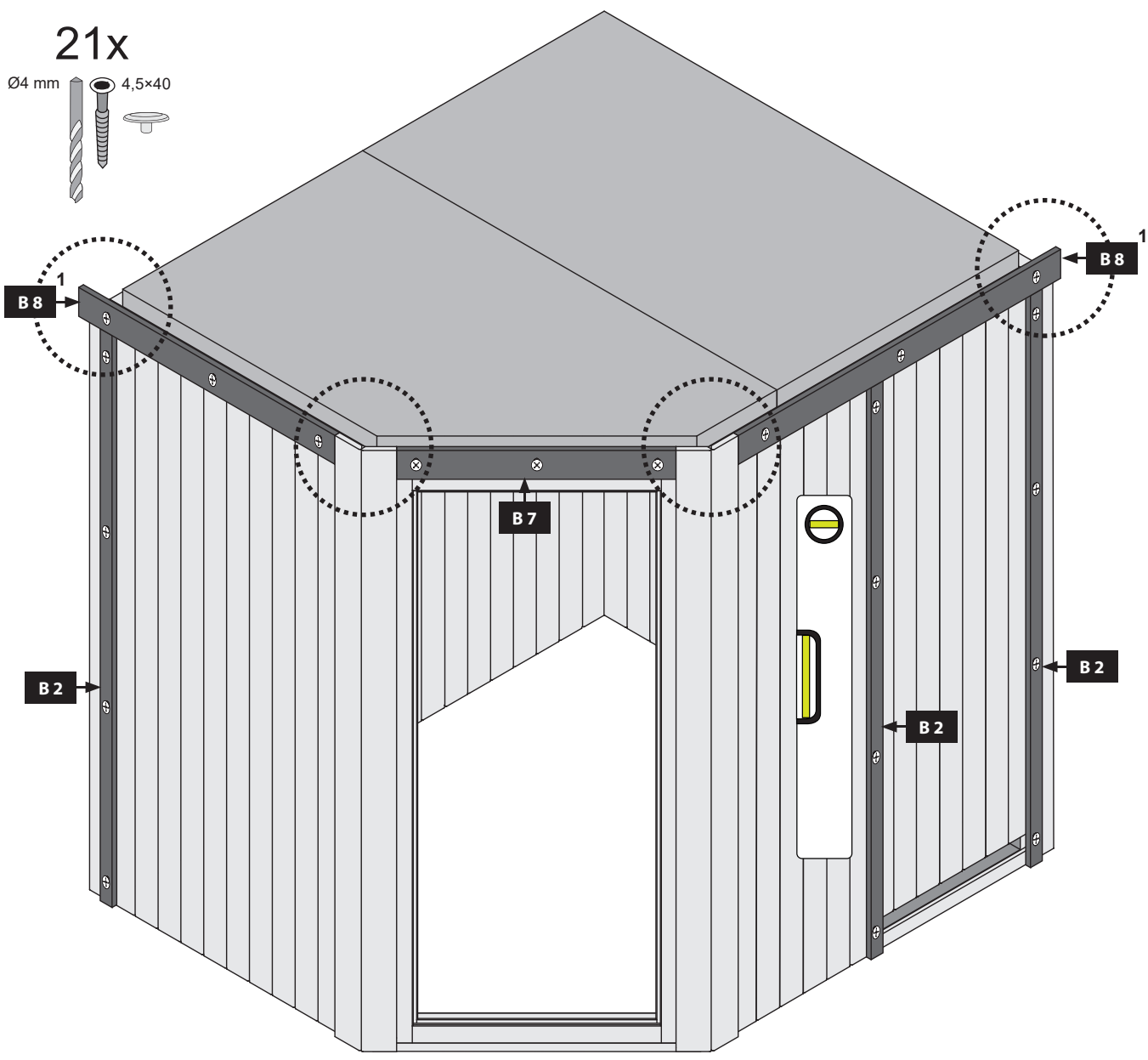
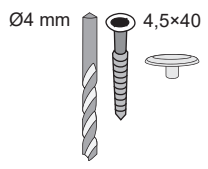

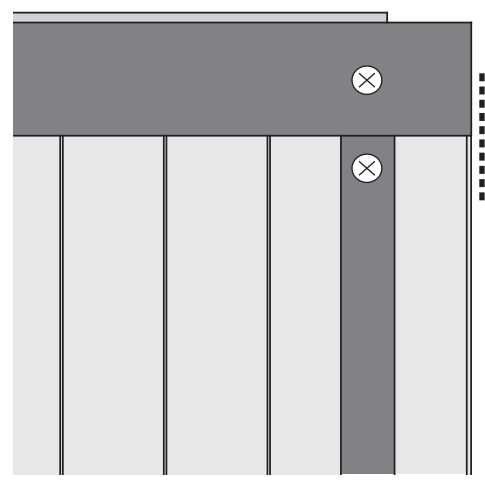

-  Bündig!
-  Flush!
-  Affleurement!
-  I flugt!
-  Gelijk!
-  Aras!
-  Combacia!
-  Stejný !



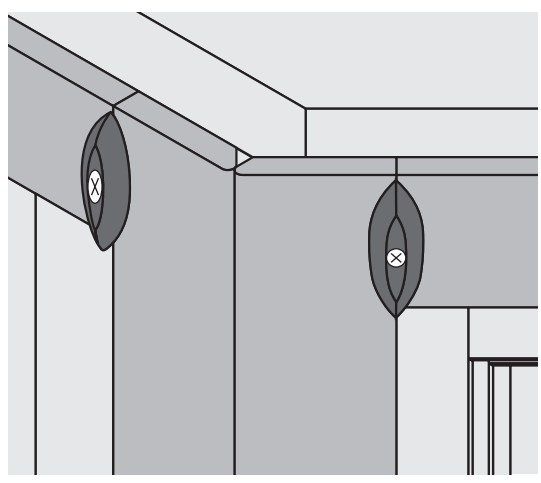
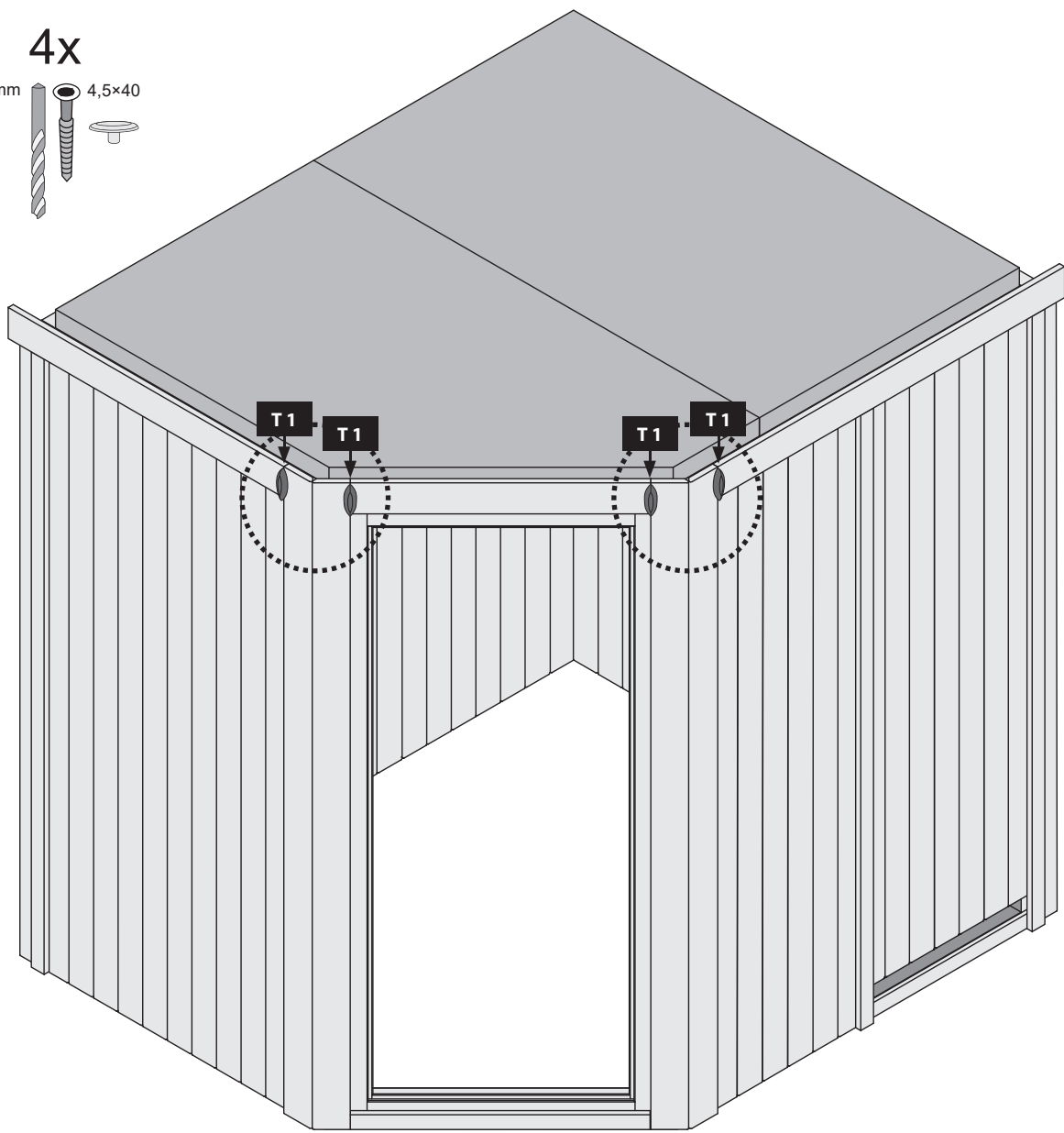

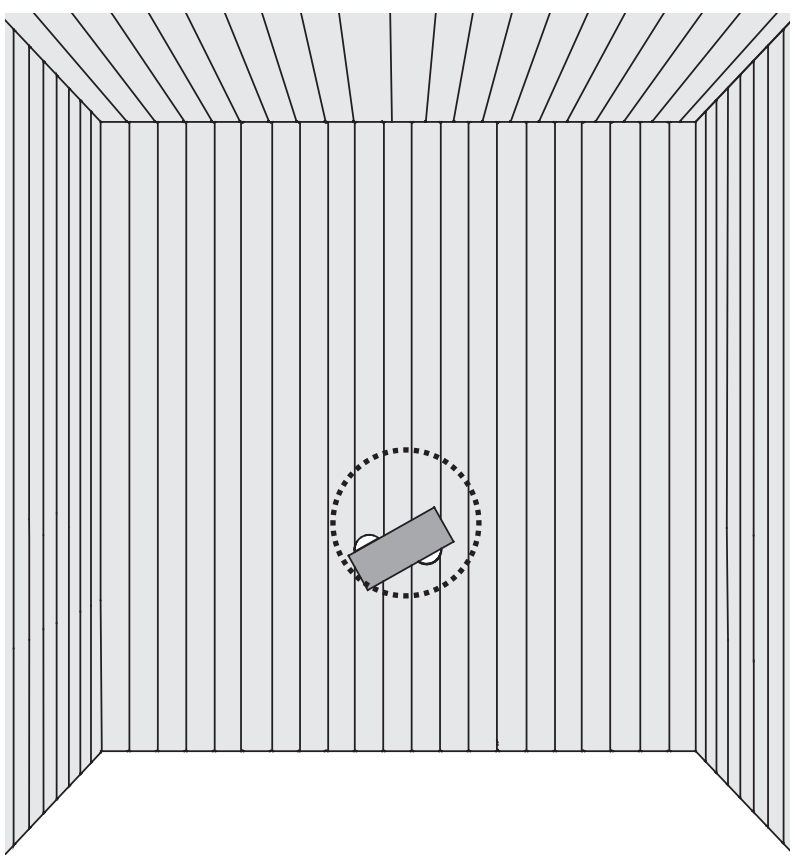
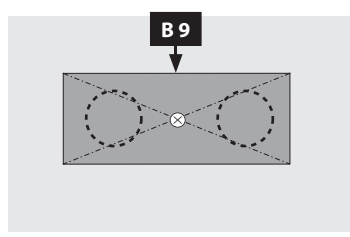
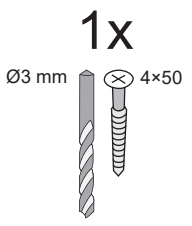
4x
Ø4 mm 4,5x40







 Hier ist die Funktionsweise des Brettes abgebildet. Regeln Sie damit die Abluft nach Ihren eigenen Wünschen

 This figure shows the functional principle of the board. Regulate the exhaust air according to your own wishes

 Ceci représente le mode de fonctionnement de la planche. Avec elle, réglez l'écoulement de l'air selon vos désirs.

 Hier is de werking van het plankje afgebeeld. Regel daarmee de luchtafvoer naar eigen wens

 Sådan fungerer styret. Brug den til at regulere udstødningsluften efter dine egne ønsker

 Aquí está representada la forma de funcionamiento de la tabla. Regule con ello el aire de salida según sus propios deseos

 Viene illustrato il principio di funzionamento della tavoletta di regolazione della ventilazione. Con essa si può regolare a piacere la ventilazione

 Zde je zobrazená funkce desky. Regulujte s ní odsávací vzduch dle Vašeho přání

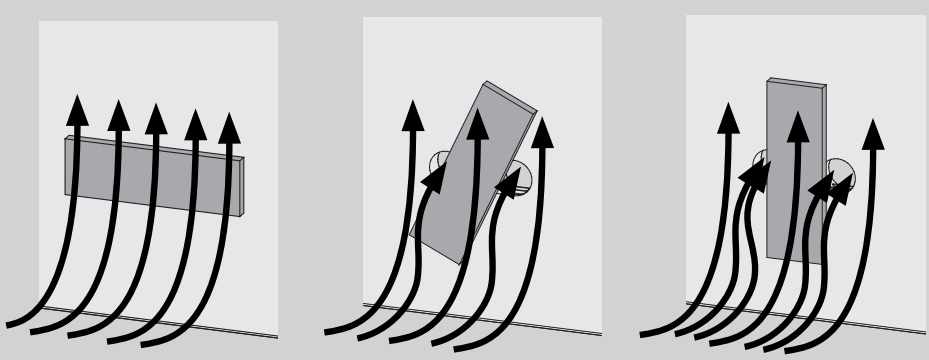

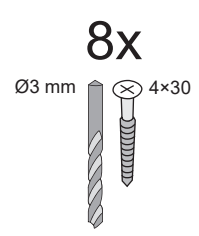
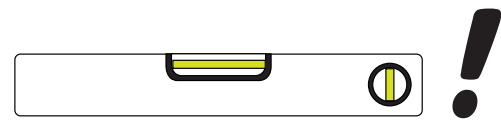
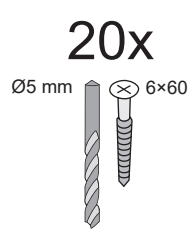
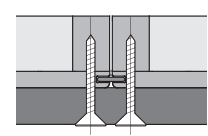
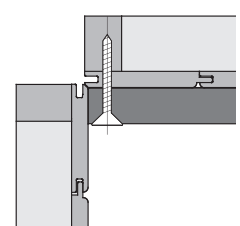
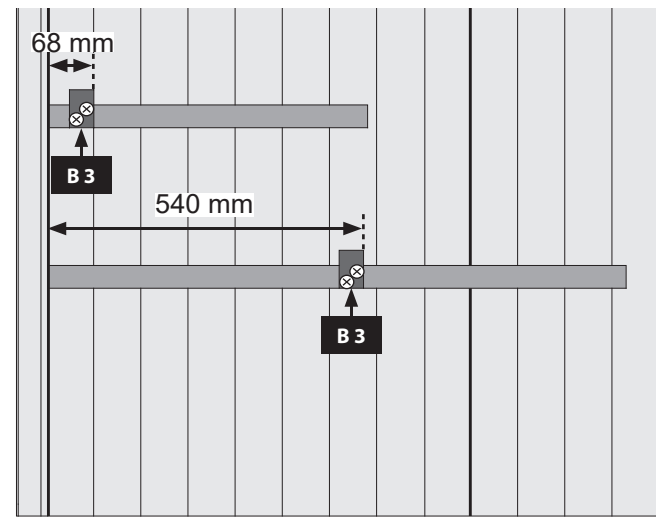
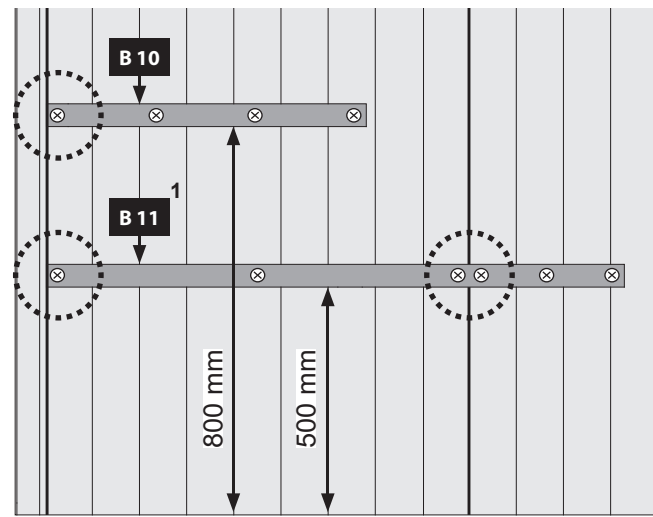
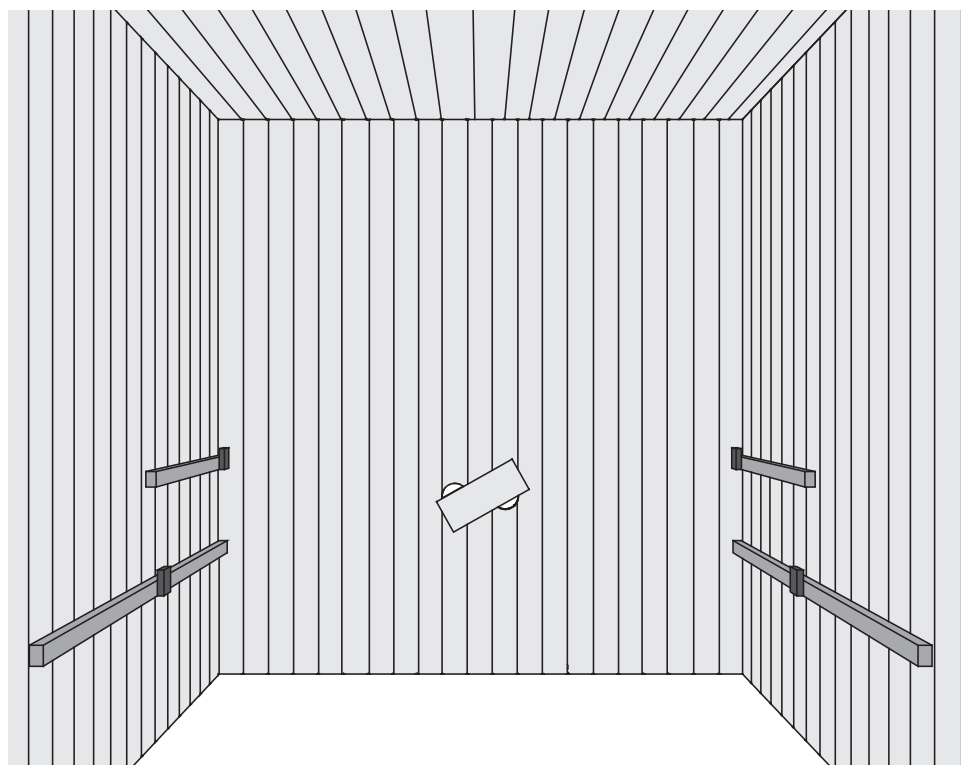
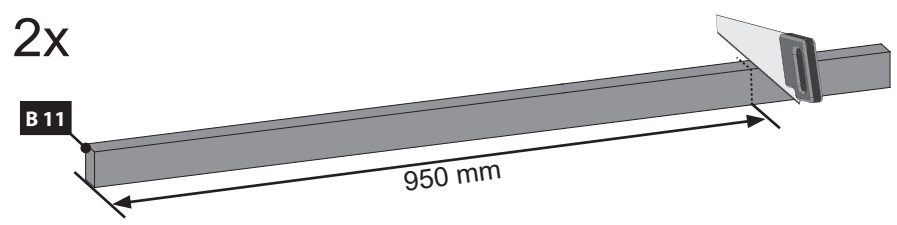



-  Ansicht unten
-  View below
-  Voir ci-dessous
-  Bekijk hieronder
-  Se nedenfor
-  Ver abajo
-  Visualizza sotto
-  Zobrazit níže



10x

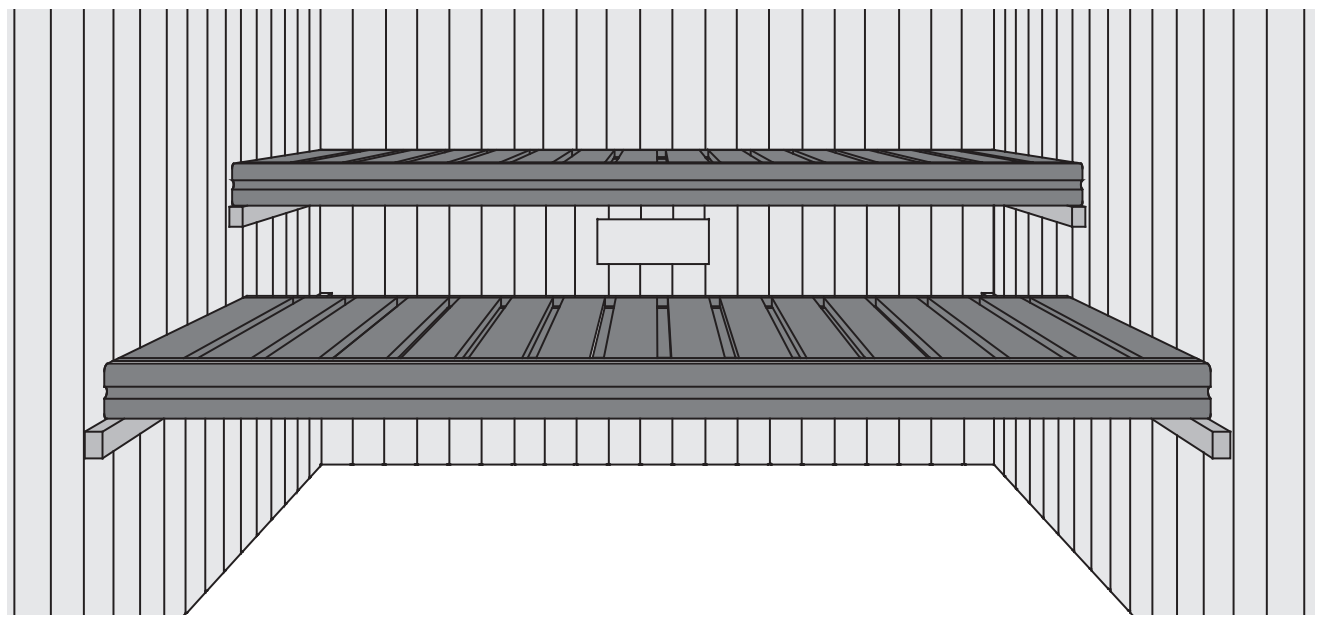
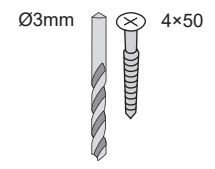

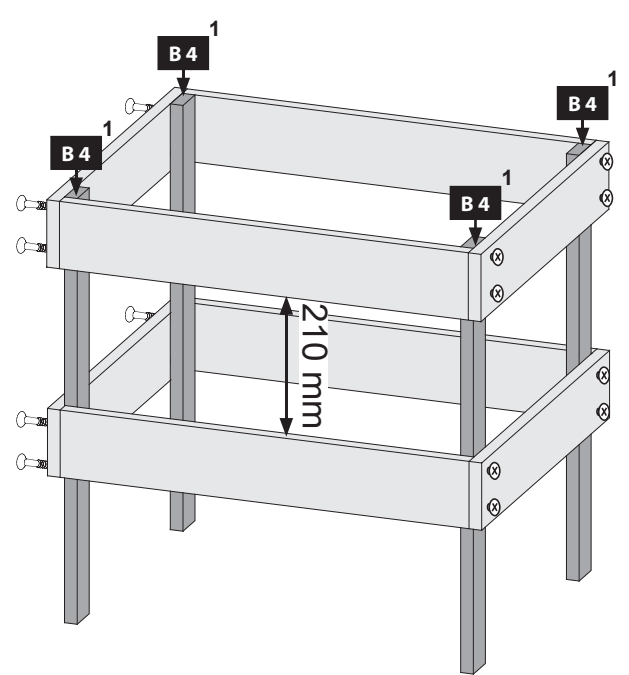
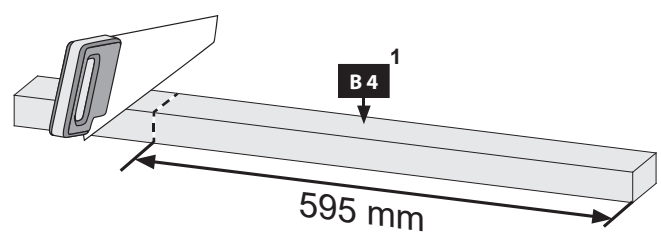
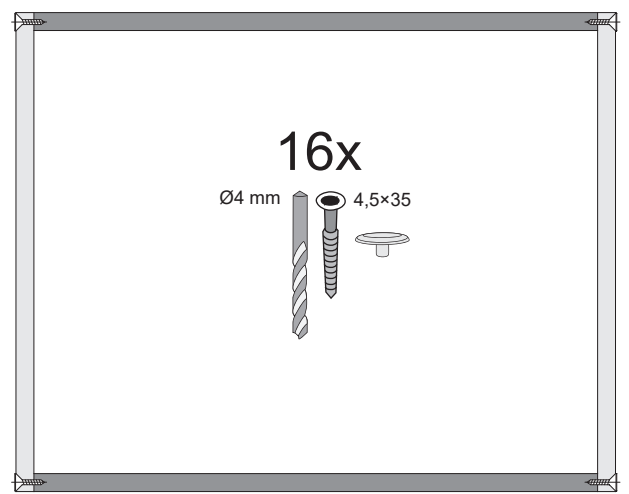
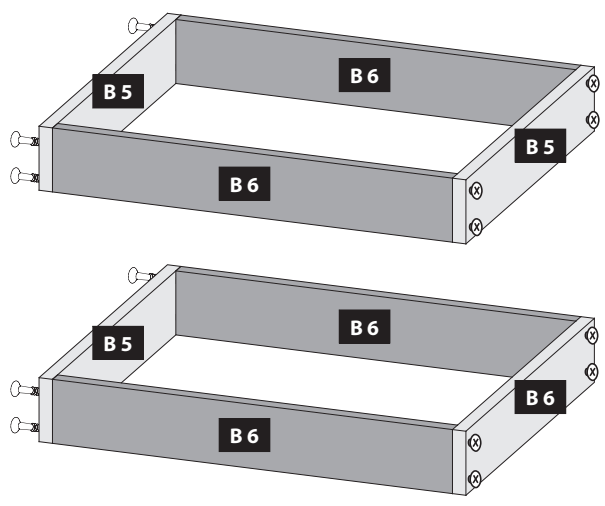

-  Nur bei 9 / 4,5 kW-Ofen
-  Only 9 / 4,5 kW heater
-  Seulement 9 / 4,5 kW chauffe
-  Kun ved 9 / 4,5 kW ovn
-  Slechts 9/4,5 kW heater
-  Sólo calentador de 9 / 4,5 kW
-  Solo riscaldamento 9 / 4,5 kW
-  Pouze topné těleso 9 / 4,5 kW

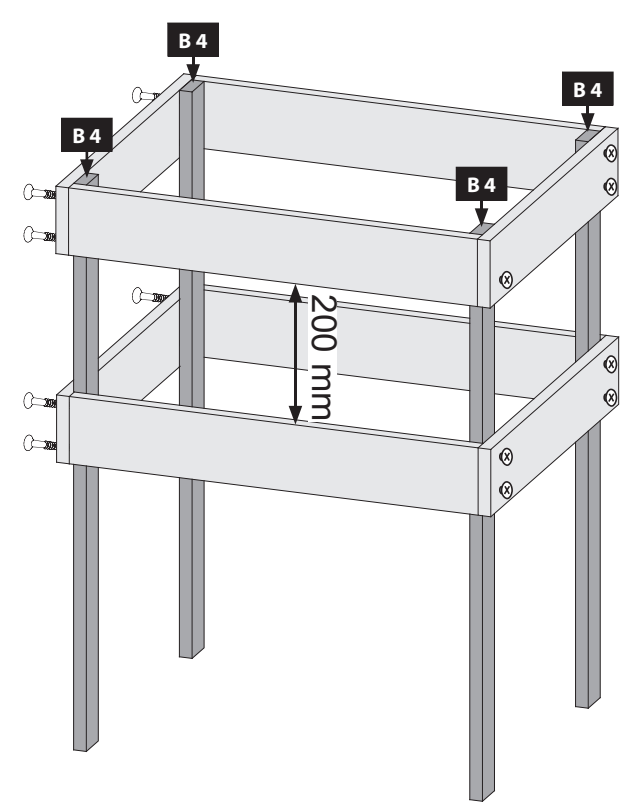
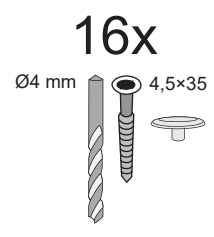

-  Bei allen anderen Öfen
-  For all other furnaces
-  Pour tous les autres fours
-  Kun ved 9 kW ovn
-  Voor alle andere ovens
-  Para todos los otros hornos
-  Per tutti gli altri tipi di forni
-  U všech ostatních pecích

4x

Ø3 mm 4,5x35

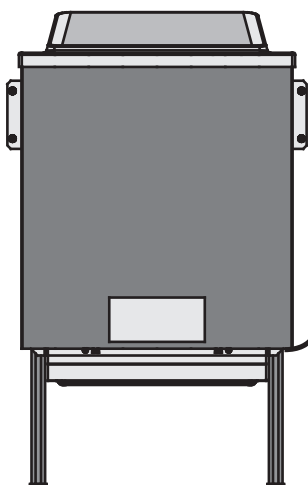
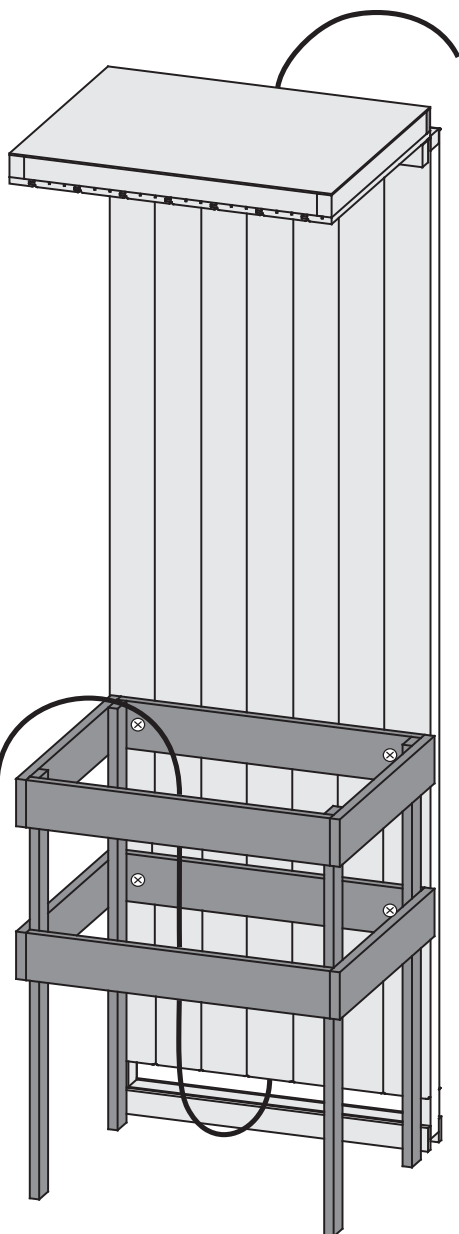
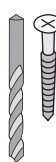

-  Ofenbefestigung
-  oven fixing
-  fixation four
-  oven vaststelling
-  ovn fastsættelse
-  fijación horno
-  fissaggio forno
-  upevňovací trouba

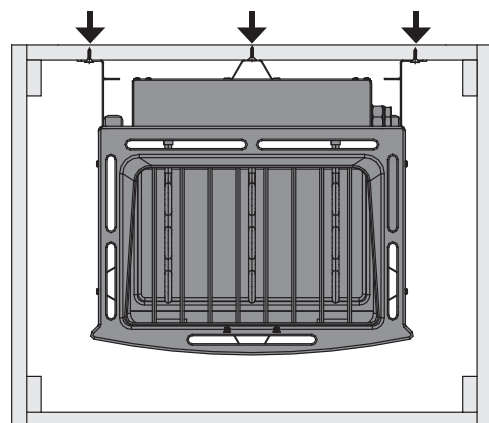
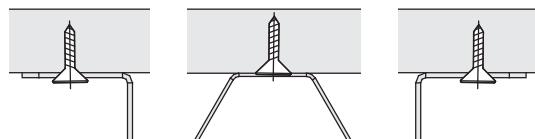

-  Einbau Tür
-  Installation door
-  Porte d'installation
-  Installatie deur
-  Installationsdør
-  Puerta de instalación
-  Porta di installazione
-  Montážní dveře
-  Vgradna vrata



06 — ...

